

SMARTCAP®

INSTRUCTION GUIDE

DROP RACK EVO III ADAPTER

2016-2023 TOYOTA TACOMA

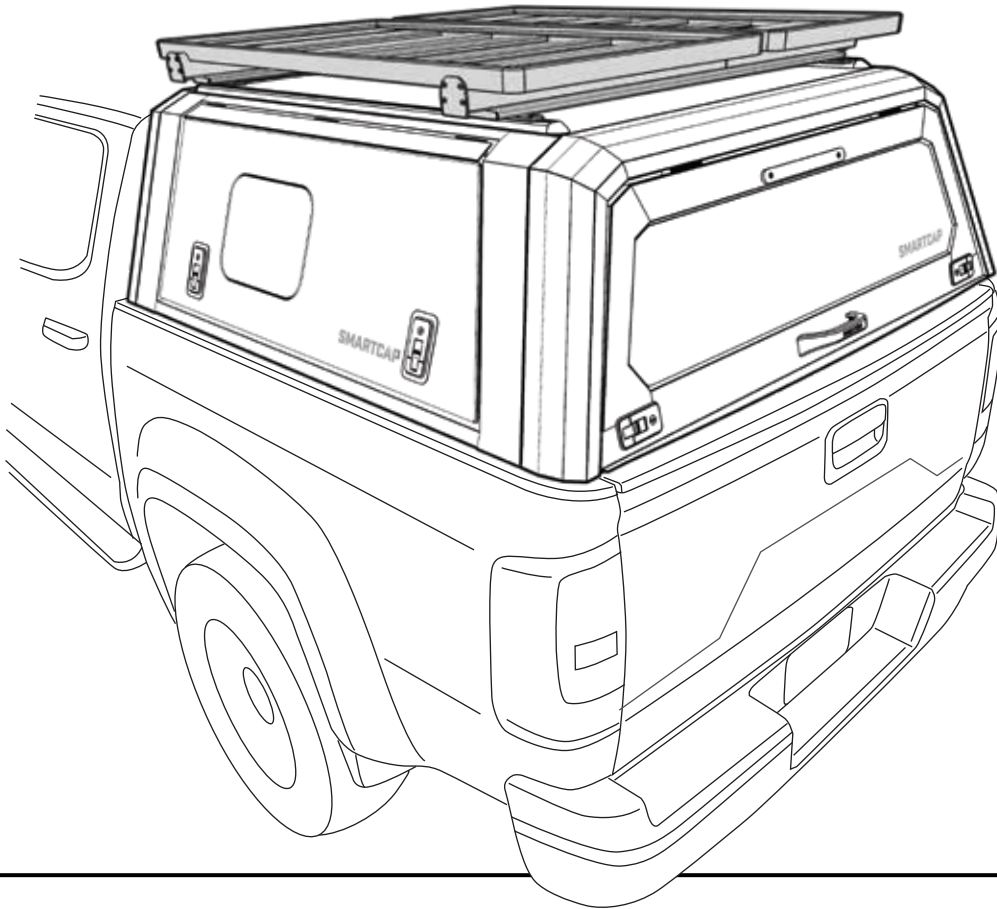

- ▼ **PREPARE A CLEAN WORK AREA.**
- ▼ **WE RECOMMEND A MINIMUM OF 2 PEOPLE FOR ASSEMBLY.**
- ▼ **ENSURE THE REQUIRED TOOLS ARE PRESENT AND ALL HARDWARE CONTENTS ARE ACCOUNTED FOR.**
- ▼ **NEVER USE ACETONE OR THINNERS ON PAINTED PARTS.**
- ▼ **READ THROUGH THE ENTIRE INSTRUCTION GUIDE BEFORE STARTING THIS PROCEDURE AND FOLLOW THE STEPS CAREFULLY TO AVOID ANY DAMAGE TO THE COMPONENTS OR THE VEHICLE.**

SUPPORT.NA@SMARTCAP.COM - NORTH AMERICA
SUPPORT.SA@SMARTCAP.COM - REST OF WORLD

SMARTCAP.COM



I-SHEET-NA-DRA

TOOLS REQUIRED

Rivet Gun



Tape Measure



Allen Key



5mm

Power Drill



5mm Bit

Scissors



IMPORTANT

- ▼ USE ONLY THE TOOLS RECOMMENDED ABOVE.
- ▼ USE ONLY THE HARDWARE PROVIDED IN THIS KIT.
- ▼ ASSISTANCE WILL BE NEEDED FOR THIS INSTALLATION.
- ▼ AVOID PINCHING OR CRUSHING HANDS AND FINGERS.
- ▼ INSPECT ALL KIT COMPONENTS FOR DAMAGE BEFORE ASSEMBLY.
- ▼ NEVER USE ACETONE OR THINNERS ON PAINTED PARTS.

ASSEMBLY HARDWARE

MOUNTING PLATE ADAPTER

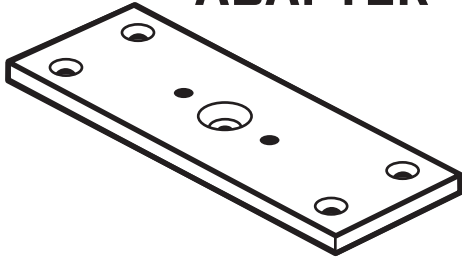

4X

M8x30mm BUTTON HEAD BOLT



8X

POP RIVETS

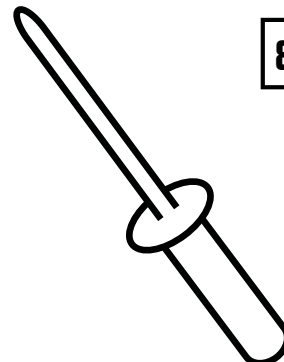

8X

I-SHEET-NA-DRA

STEP 1

REMOVE THE DROP RACK FROM ITS PACKAGING AND LAY IT DOWN WITH THE MOUNTING PLATES FACING UPWARDS.

2 PERSON JOB

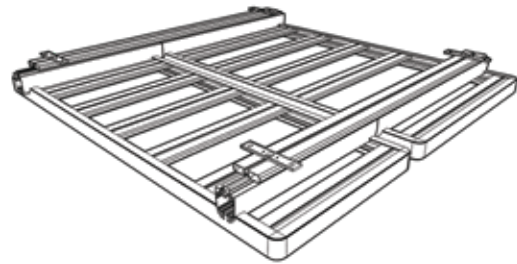
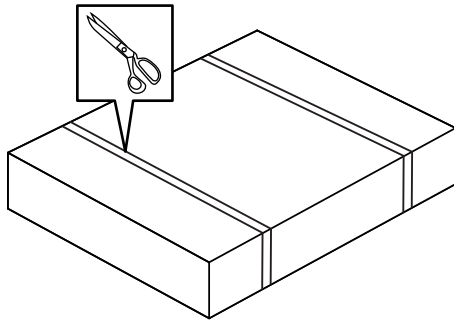

STEP 2

REMOVE THE RIVETS LOCATED ON THE MOUNTING PLATE OF THE DROP RACK BY DRILLING THROUGH THEM WITH A 5MM DRILL BIT AND A POWER DRILL (2 PER PLATE).

REPEAT ON ALL 4 MOUNTS

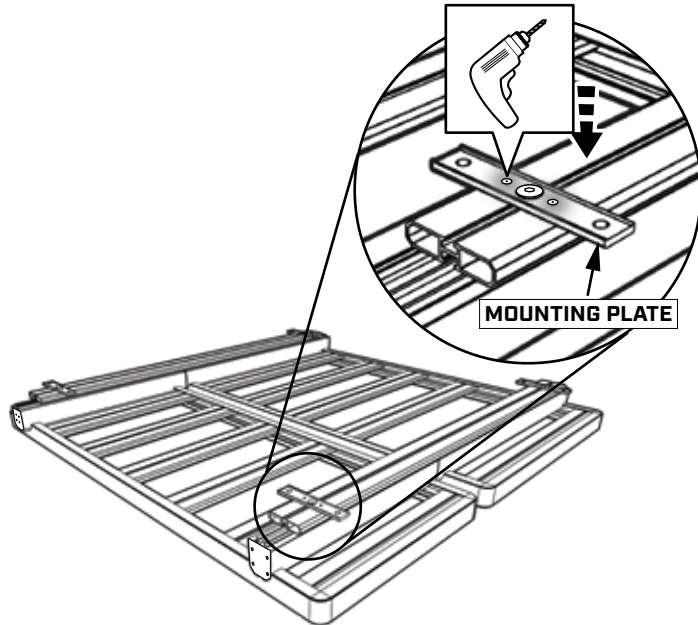
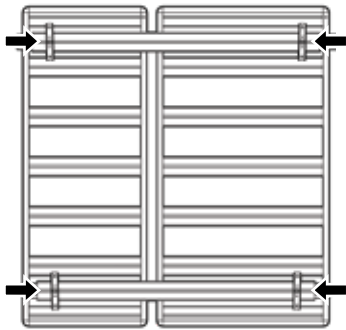

STEP 3

REMOVE THE M8 SCREW LOCATED ON THE MOUNTING PLATE WITH A 5MM ALLEN KEY.

REPEAT ON ALL 4 MOUNTS

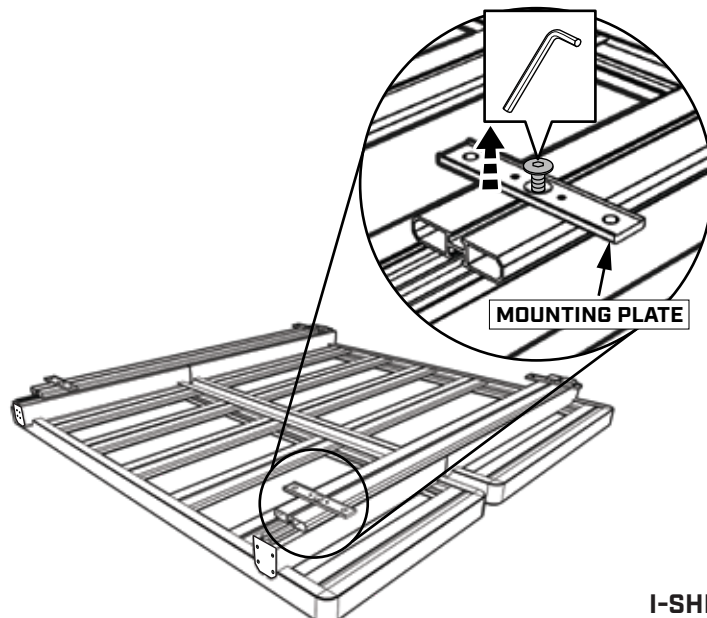
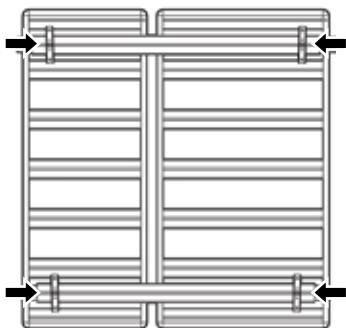

I-SHEET-NA-DRA

STEP 4

REMOVE THE MOUNTING PLATE FROM THE BOTTOM OF THE DROP RACK, LEAVING THE MOUNTING SPACER IN PLACE. SAVE THE MOUNTING PLATE FOR REUSE LATER ON.

REPEAT ON ALL 4 MOUNTS

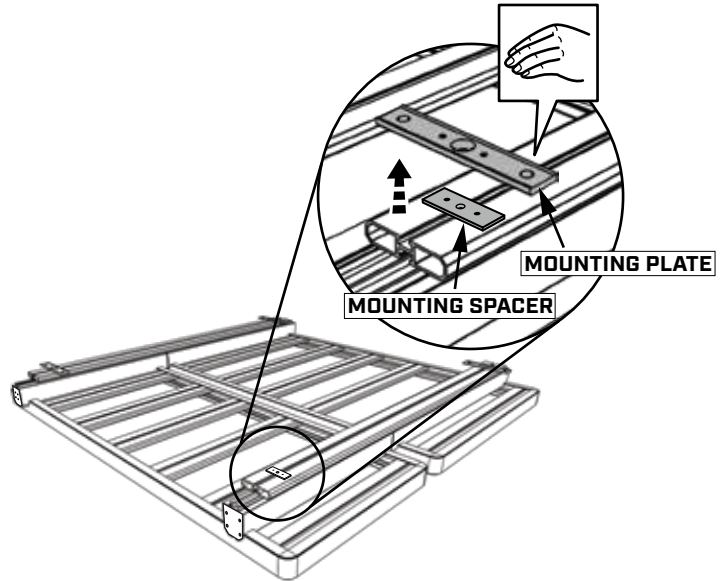
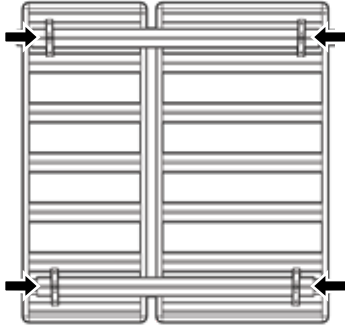

STEP 5

PLACE THE MOUNTING PLATE ADAPTER ON TOP OF THE MOUNTING SPACER.

REPEAT ON ALL 4 MOUNTS

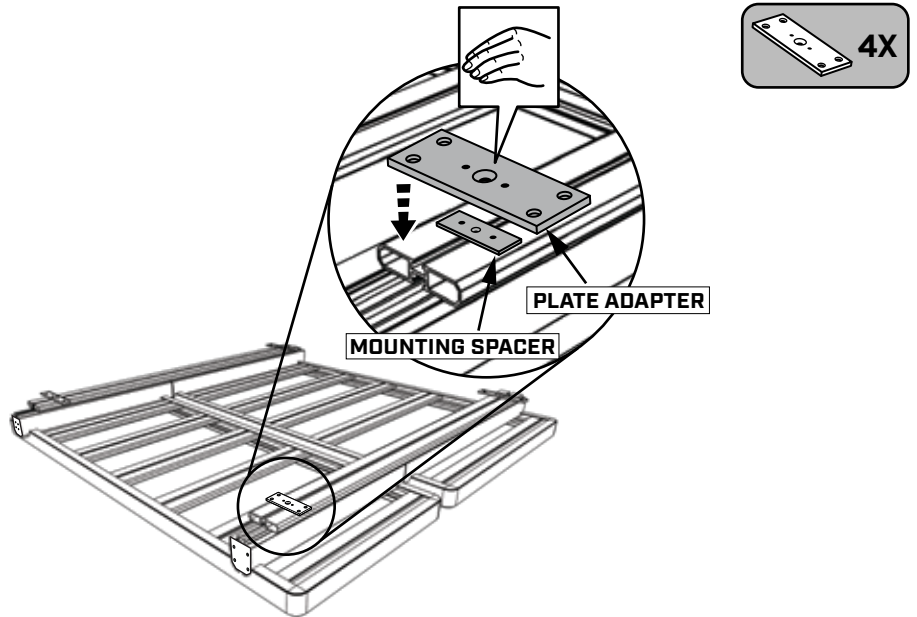
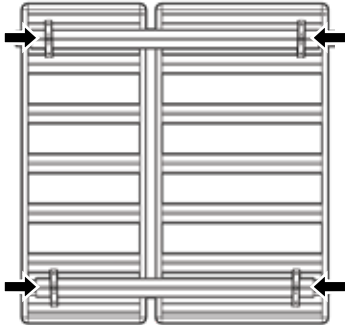

STEP 6

PLACE THE PROVIDED RIVETS INTO THE HOLES WHERE THE PREVIOUS RIVETS WERE LOCATED, ALIGNING THE ADAPTER TO THE SPACER AND DROP RACK BASE.

REPEAT ON ALL 4 MOUNTS

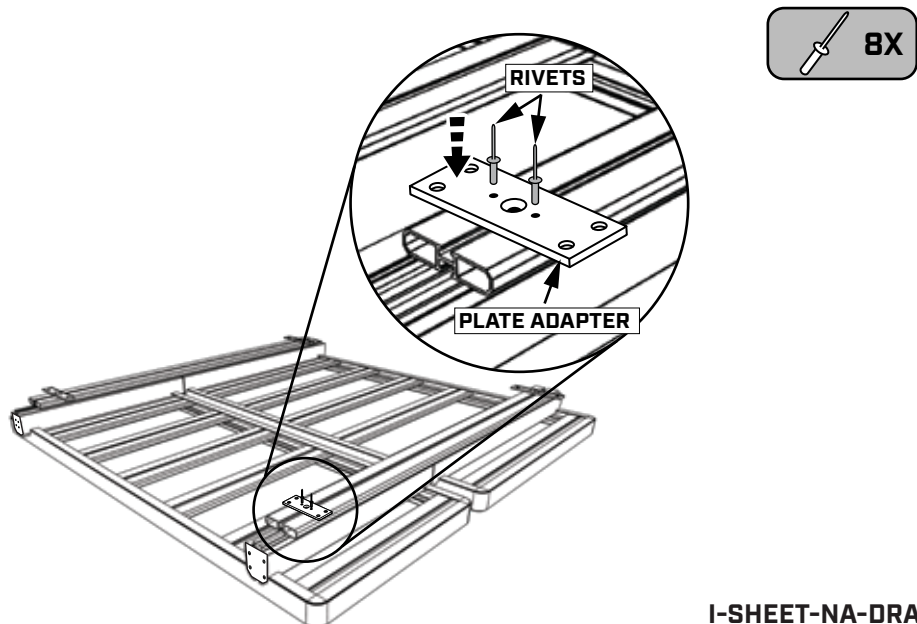
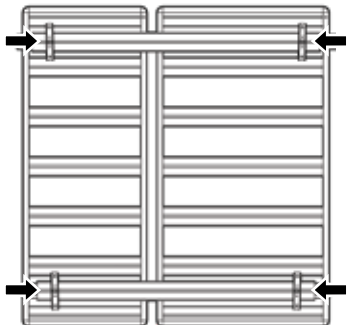

I-SHEET-NA-DRA

STEP 7

LOOSELY TIGHTEN THE MOUNTING
PLATE ADAPTER TO THE BASE OF
THE DROP RACK USING THE M8
SCREW FROM MOUNTING PLATE

REPEAT ON ALL 4 MOUNTS

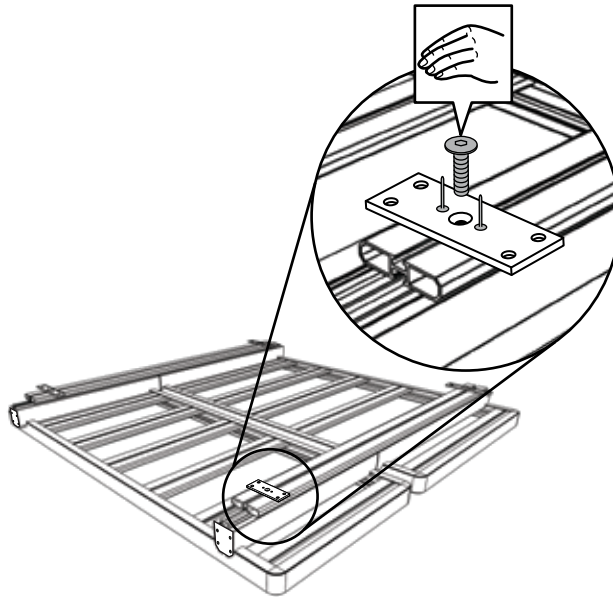
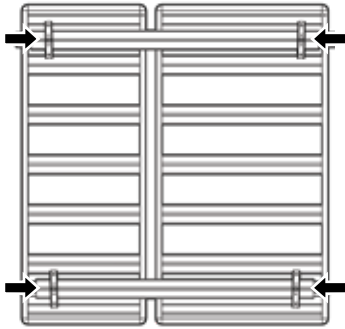

STEP 8

RIVET THE POP RIVETS IN PLACE
USING A RIVET GUN TOOL.

REPEAT ON ALL 4 MOUNTS

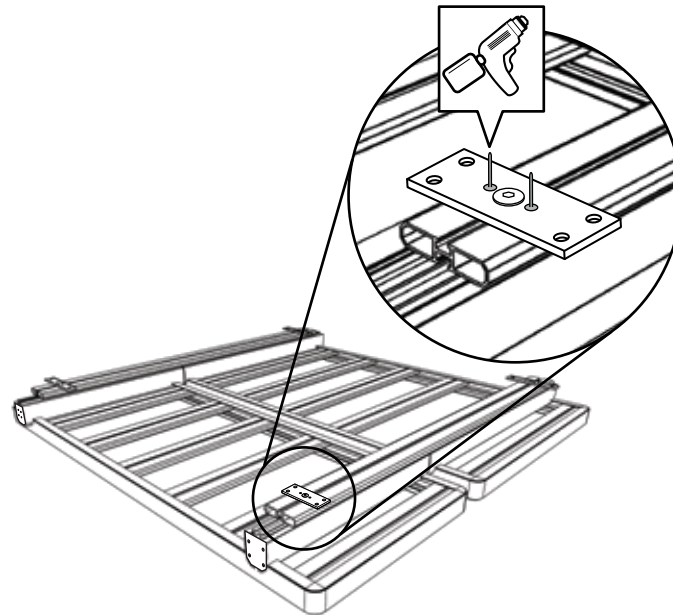
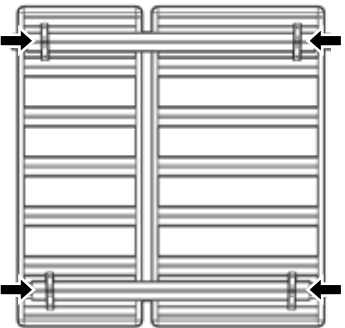

STEP 9

FULLY TIGHTEN THE M8 SCREW
USING A 5MM ALLEN KEY.

REPEAT ON ALL 4 MOUNTS

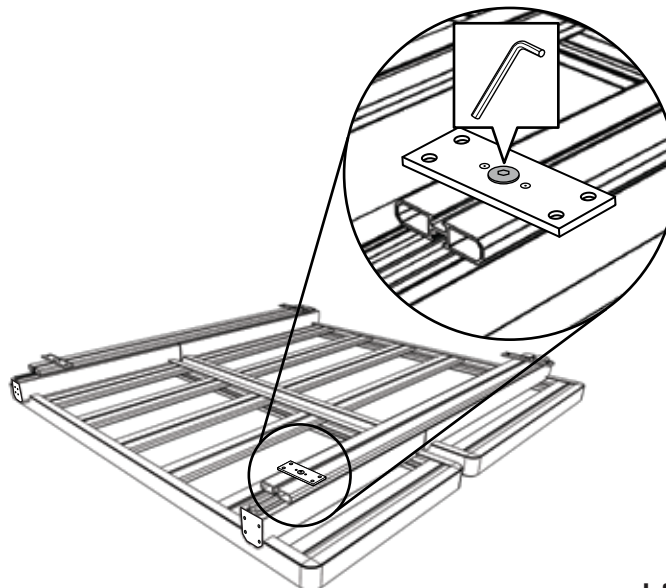
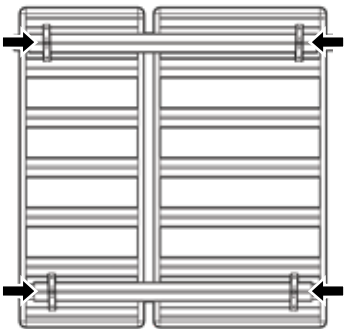

I-SHEET-NA-DRA

STEP 10

PLACE THE DROP RACK ON TOP OF THE SMARTCAP, WITH THE MOUNTING PLATE ADAPTERS ALIGNING PARALLEL TO THE ROOF RAILS.



 **STICKER INDICATES FRONT**

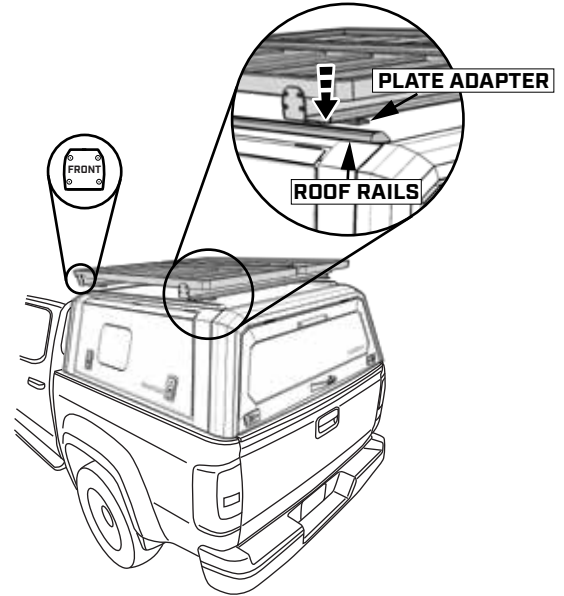
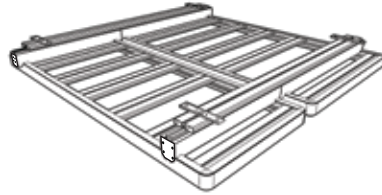

STEP 11

SLIGHTLY LIFT THE CORNER OF THE DROP RACK AND SLIDE THE MOUNTING PLATE IN BETWEEN THE MOUNTING PLATE ADAPTER AND THE ROOF RAIL.

REPEAT ON ALL 4 MOUNTS

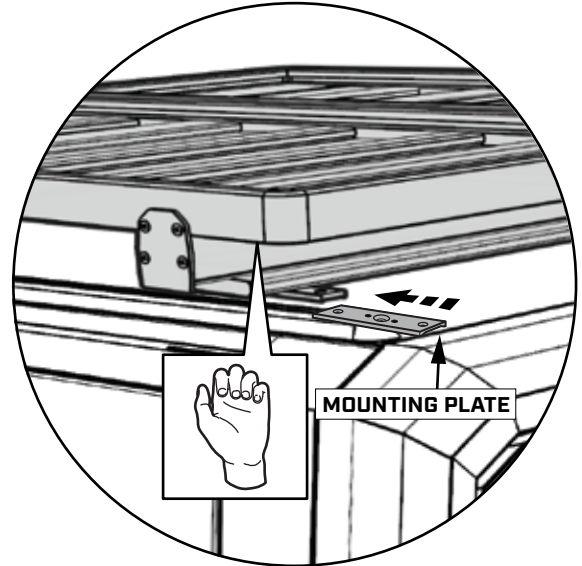
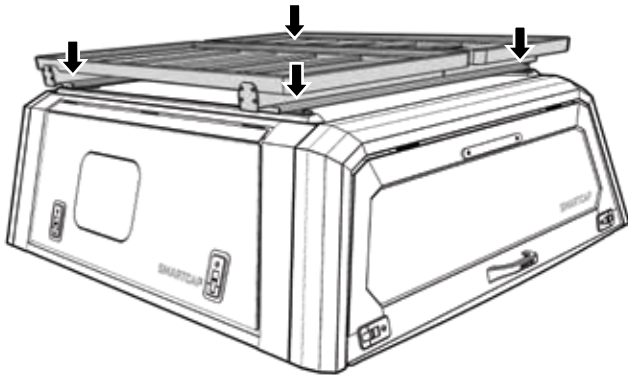

STEP 12

ADJUST THE POSITION OF THE WELD NUTS LOCATED ALONG THE INSIDE OF THE ROOF RAILS SO THAT THE THREADS ALIGN WITH THE HOLES OF THE MOUNTING PLATE ADAPTER.

NOTE: USE AN ALLEN KEY TO MANEUVER THE WELD NUTS INTO THE CORRECT POSITION.

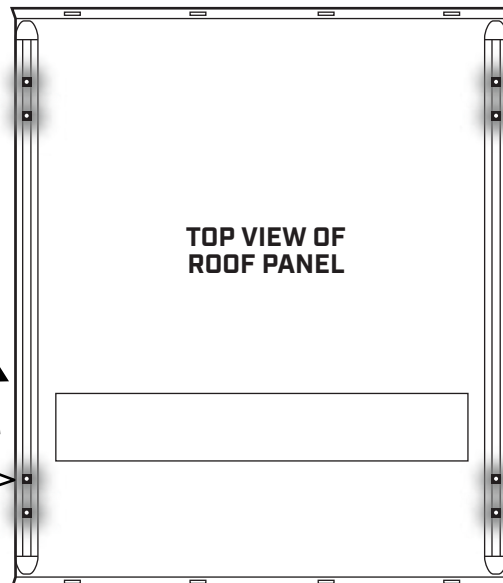
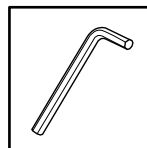

I-SHEET-NA-DRA

STEP 13

LOOSELY TIGHTEN THE DROP RACK TO THE SMARTCAP WITH M8 BUTTON BOLT, M8 LOCK WASHER, AND M8 FENDER WASHER.

BE SURE THE M8 BUTTON BOLT IS PROPERLY THREADED INTO THE WELD NUT LOCATED WITHIN THE SMARTCAP'S ROOF RAILS.

REPEAT ON ALL 4 MOUNTS

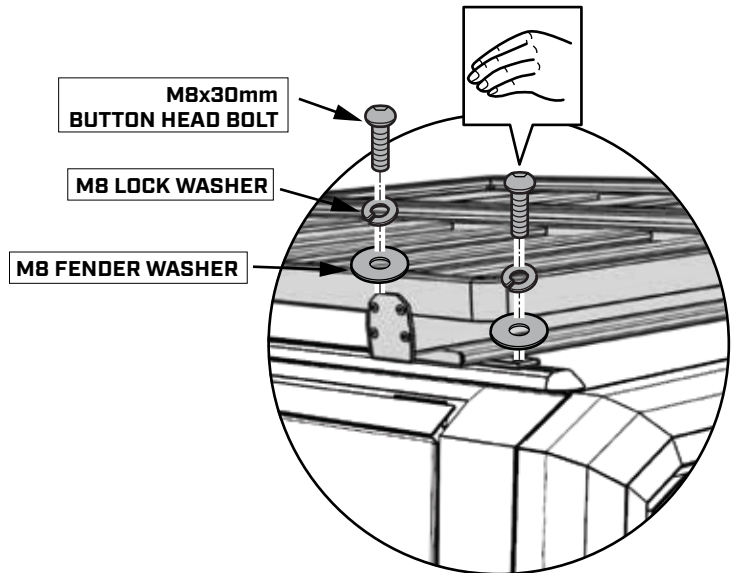
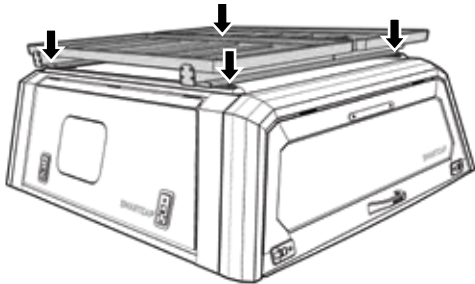

STEP 14

USE A TAPE MEASURE TO DETERMINE THE BEST POSITION FOR THE DROP RACK WITH AN EVEN AMOUNT OF SPACE FROM FRONT AND BACK.

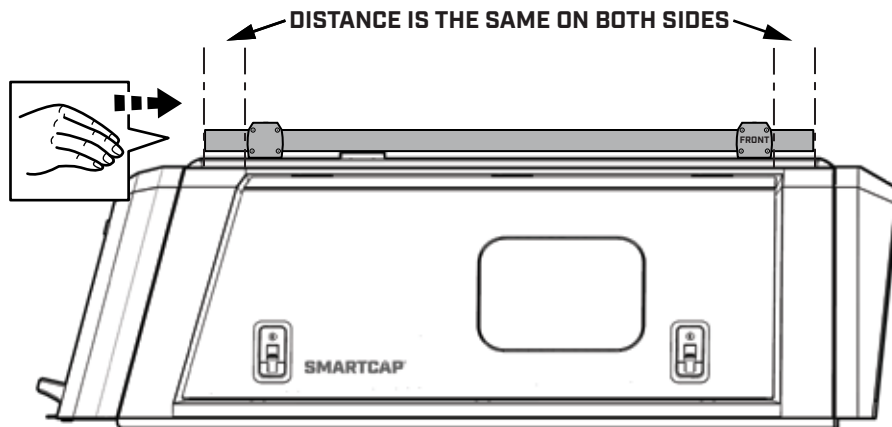

STEP 15

FULLY TIGHTEN ALL M8 BUTTON BOLTS WITH A 5MM ALLEN KEY.

REPEAT ON ALL 4 MOUNTS

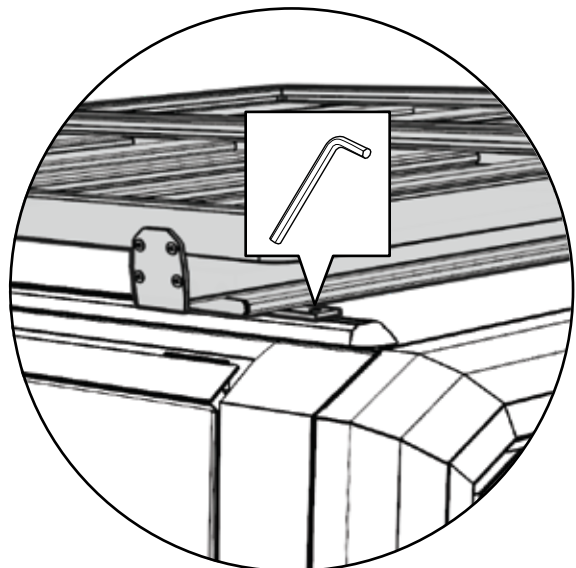
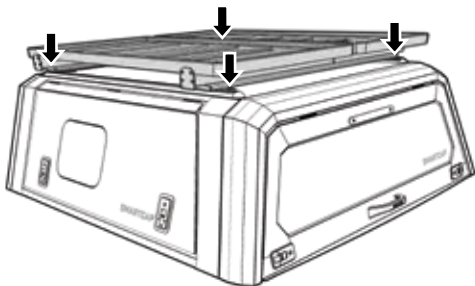

I-SHEET-NA-DRA



**THANKS FOR YOUR PURCHASE.
PLEASE LET US KNOW IF YOU HAVE ANY QUESTIONS.**

**SUPPORT.NA@SMARTCAP.COM - NORTH AMERICA
SUPPORT.SA@SMARTCAP.COM - REST OF WORLD**

