

SMARTCAP®

INSTRUCTION GUIDE

FORD RANGER EDITION

2012-2022 (5th Generation)

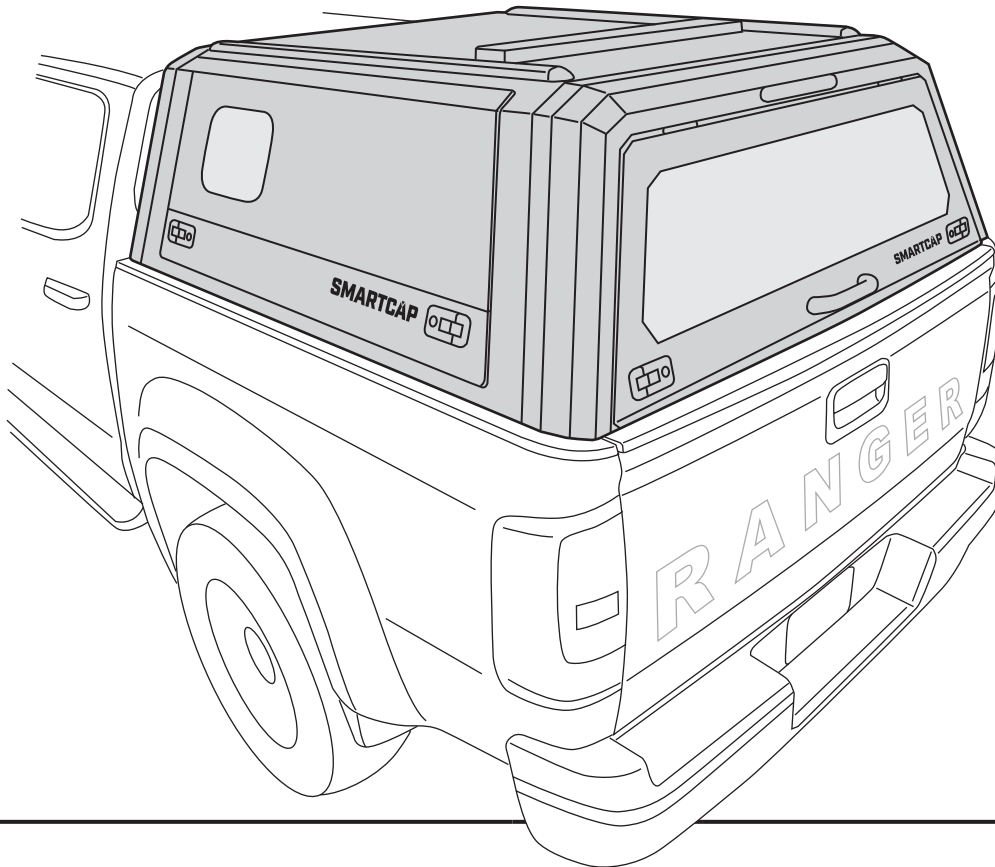

- ▼ **PREPARE A CLEAN WORK AREA.**
- ▼ **WE RECOMMEND A MINIMUM OF 2 PEOPLE FOR ASSEMBLY AND 4 PEOPLE FOR INSTALLATION.**
- ▼ **ENSURE THE REQUIRED TOOLS ARE PRESENT AND ALL HARDWARE CONTENTS ARE ACCOUNTED FOR.**
- ▼ **NEVER USE ACETONE OR THINNERS ON PAINTED PARTS.**
- ▼ **READ THROUGH THE ENTIRE INSTRUCTION GUIDE BEFORE STARTING THIS PROCEDURE AND FOLLOW THE STEPS CAREFULLY TO AVOID ANY DAMAGE TO THE COMPONENTS OR THE VEHICLE.**

SMARTCAP.COM

SUPPORT.NA@SMARTCAP.COM - NORTH AMERICA

SUPPORT.SA@SMARTCAP.COM - REST OF WORLD



I-SHEET-ROW-R2

TOOLS REQUIRED

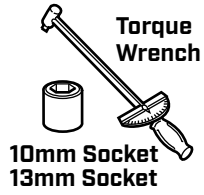
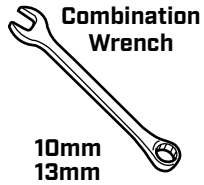
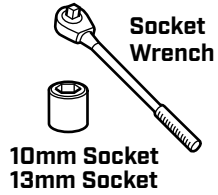

IMPORTANT

- ▼ USE ONLY THE TOOLS RECOMMENDED ABOVE.
- ▼ USE ONLY THE HARDWARE PROVIDED IN THIS KIT.
- ▼ ASSISTANCE WILL BE NEEDED FOR THIS INSTALLATION.
FOUR PEOPLE ARE RECOMMENDED TO LIFT THE SMARTCAP ONTO THE VEHICLE.
- ▼ AVOID PINCHING OR CRUSHING HANDS AND FINGERS.
- ▼ INSPECT ALL KIT COMPONENTS FOR DAMAGE BEFORE ASSEMBLY.
- ▼ NEVER USE ACETONE OR THINNERS ON PAINTED PARTS.

COMPONENTS

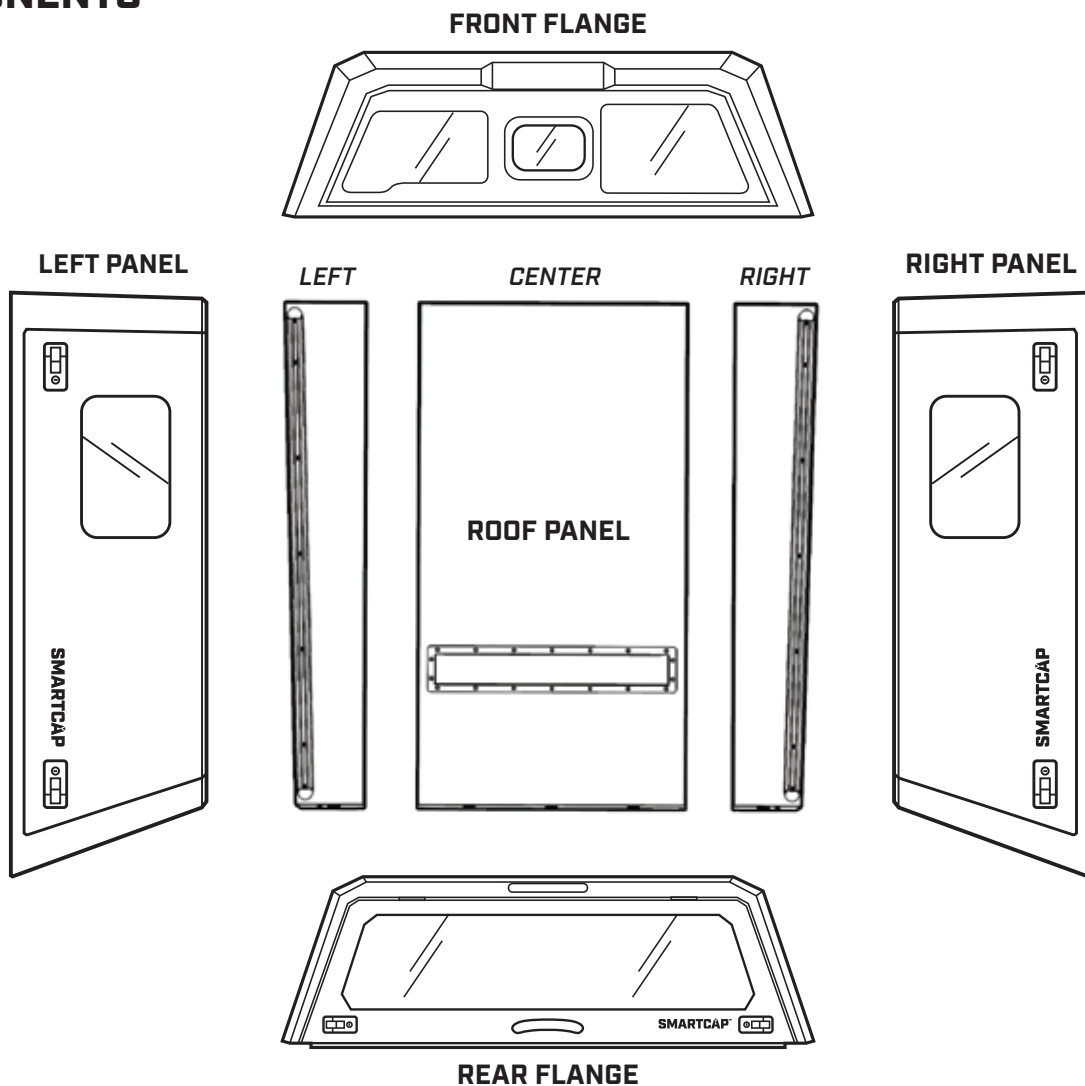

I-SHEET-ROW-R2

ASSEMBLY HARDWARE

FITMENT KIT

M6 BOLT

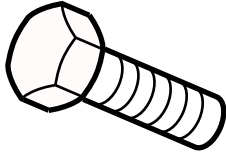

42X

**FASTENER
BLOCK CLAMP**

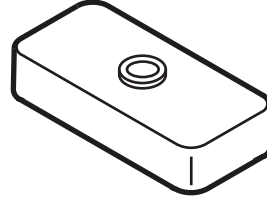

42X

**M6 LOCK
WASHER**

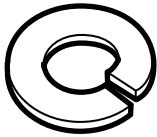

42X

**FASTENER
BLOCK**

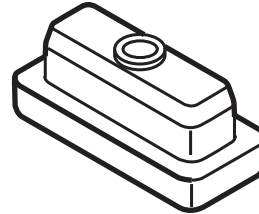

42X

O - RUBBER



1X

SPARE PARTS

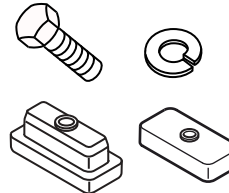

2X

PRE-FASTENED TO ROOF PANEL

**M6
FENDER WASHER**



10X

**M6
LOCK NUT**



10X

STEP 1



IMPORTANT

- ▼ BE SURE TO REMOVE ALL SEVEN PANELS FROM THEIR PACKAGING AND INSPECT THE PAINTED SURFACES PRIOR TO ASSEMBLY, AS SMARTCAP WILL NOT ACCEPT WARRANTY CLAIMS AFTER ASSEMBLY IS COMPLETED. IF MANUFACTURING IMPERFECTIONS OR SHIPPING DAMAGES ARE FOUND, DO NOT CONTINUE WITH THE ASSEMBLY PROCESS AND CONTACT SUPPORT.NA@SMARTCAP.COM

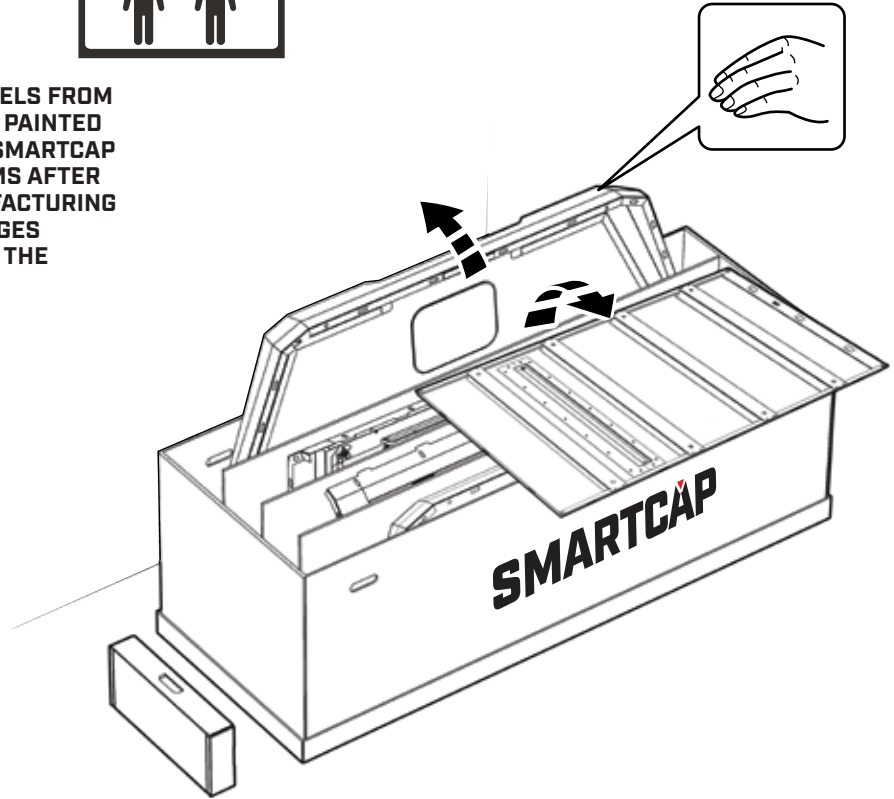

STEP 2

REMOVE THE FOUR CORNER STIFFENERS AND ONE OF THE CARDBOARD DIVIDERS TO BE USED AS A PROTECTIVE SURFACE DURING ASSEMBLY.

UNFOLD THE CARDBOARD DIVIDER AND PLACE IT WHERE YOU PLAN TO ASSEMBLE YOUR CAP.

PLACE THE FOUR CORNER STIFFENERS AS SHOWN BELOW.

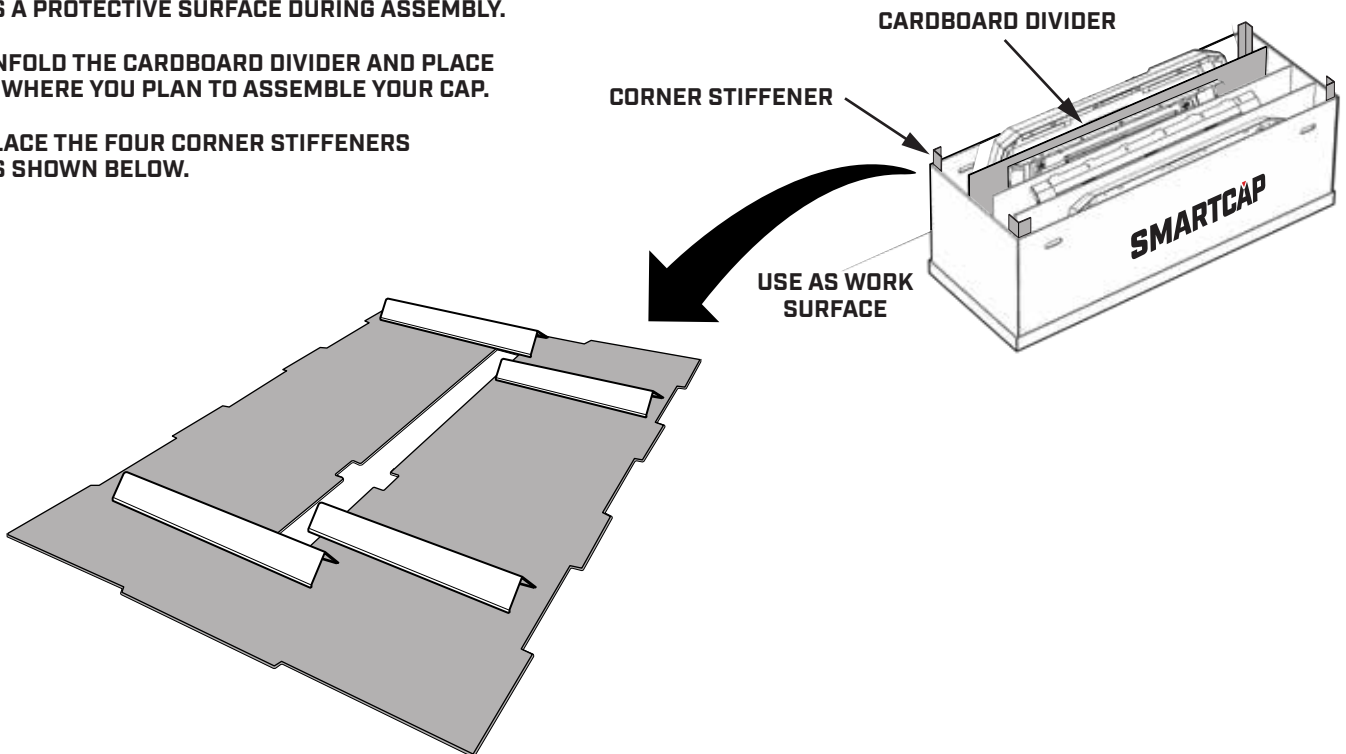

STEP 3

PLACE THE ROOF PANELS ON TOP OF THE CORNER STIFFENERS, WITH THE BOTTOM OF THE ROOF PANELS FACING UP.

ALIGN THE PANELS SO THAT THE PROFILE OF THE FRONT AND REAR EDGES MATCH.

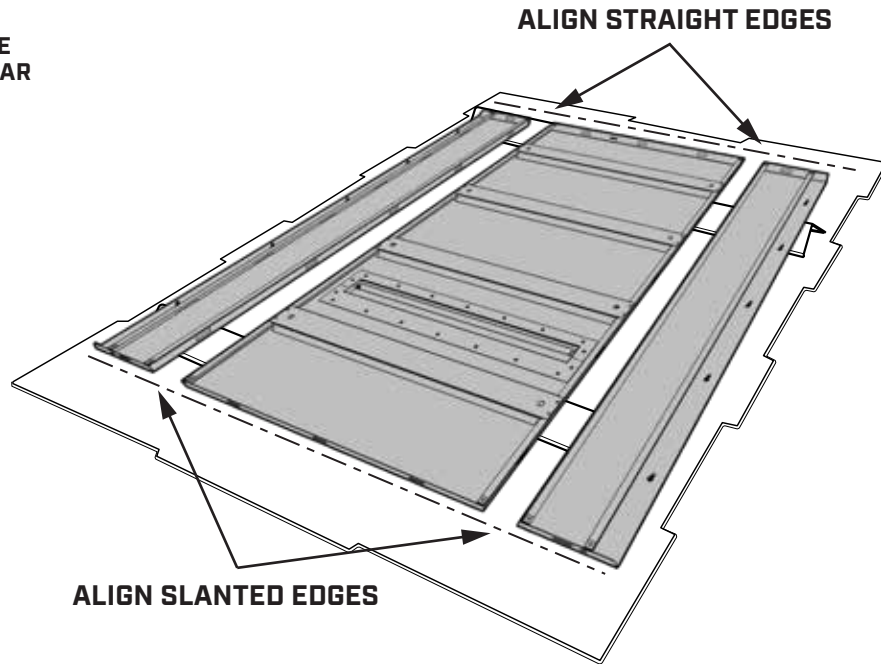

STEP 4

ASSEMBLE THE FASTENER BLOCKS TO THE ROOF PANELS USING A TORQUE WRENCH AND 10MM SOCKET TO 3.7 FT. LBS [5 NEWTON METERS].

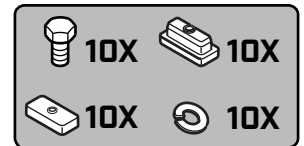

MAKE SURE ROOF PANELS ARE LEVEL

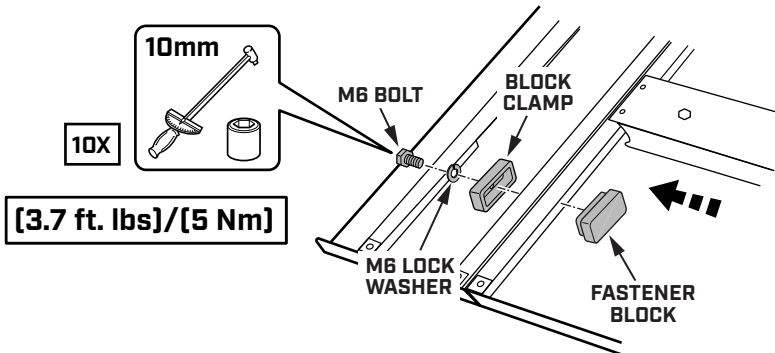
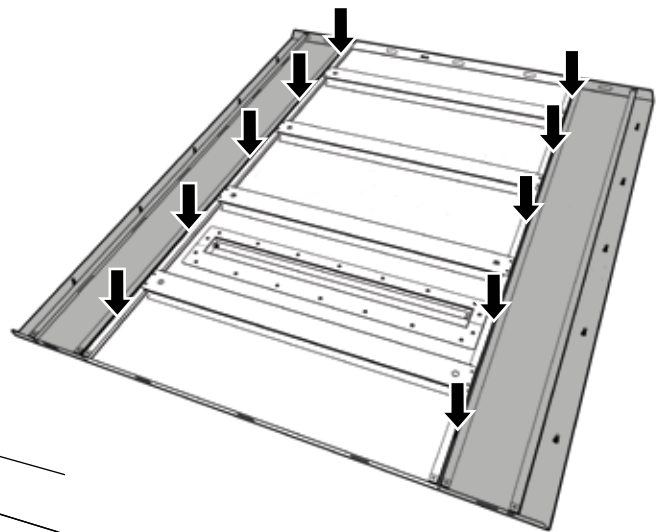

I-SHEET-ROW-R2

STEP 5

USE A 10MM COMBINATION WRENCH TO REMOVE THE LOCK NUTS AND FENDER WASHERS FROM THE ROOF BOLTS AND SAVE FOR REUSE.



AIR VENT INDICATES REAR

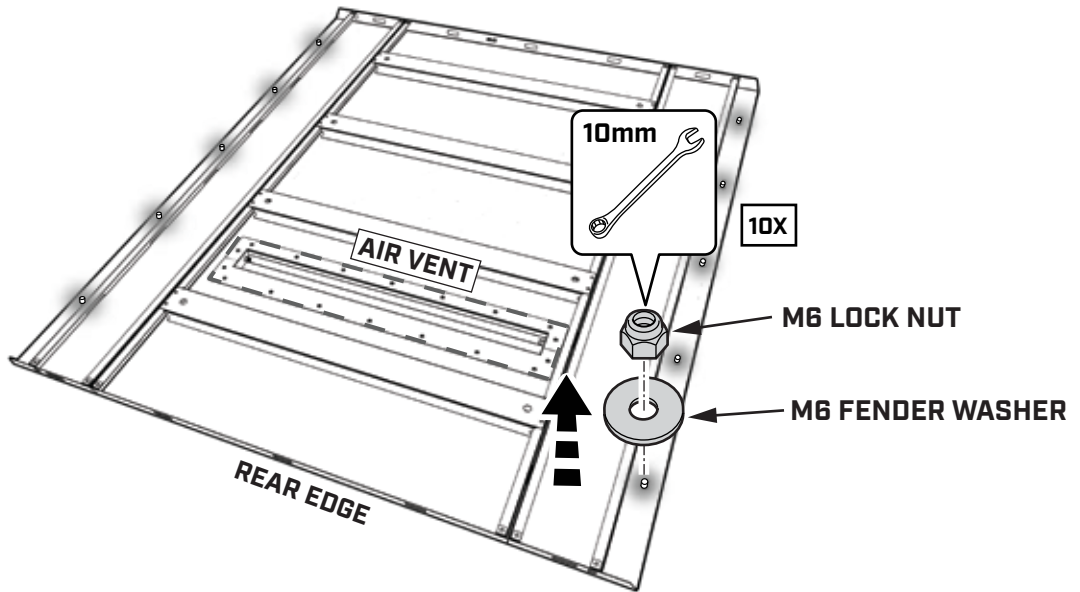

STEP 6

RETRIEVE THE FASTENER BLOCKS FROM THE FITMENT KIT AND PLACE 15 ON EACH SIDE OF THE ROOF PANEL.

TAKE APART THE FASTENER BLOCKS SO THEY ARE READY TO USE DURING ASSEMBLY.

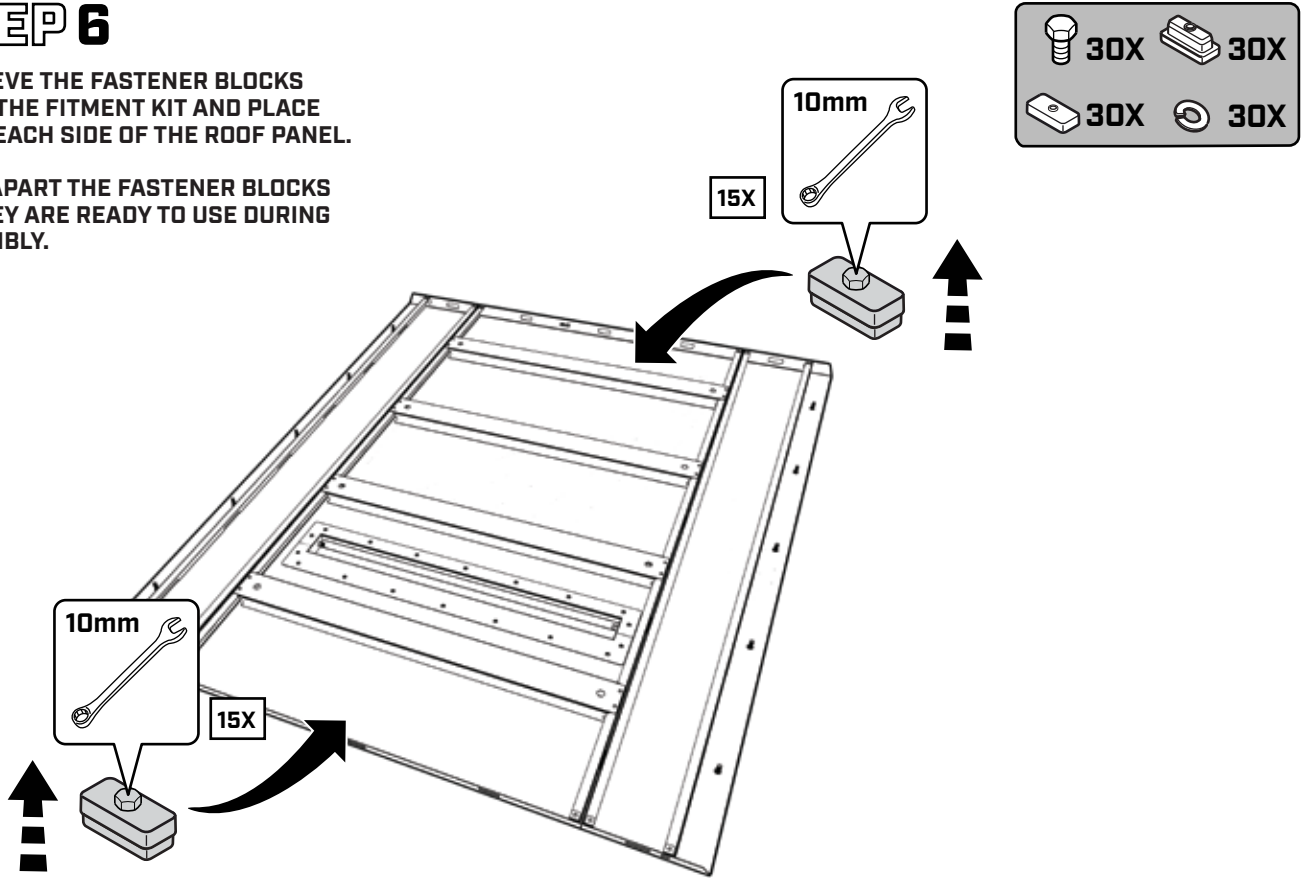

I-SHEET-ROW-R2

STEP 7

LOCATE THE RIGHT PANEL IN THE SMARTCAP PACKAGE AND BRING IT TO YOUR WORK AREA.



SLANTED EDGE INDICATES REAR

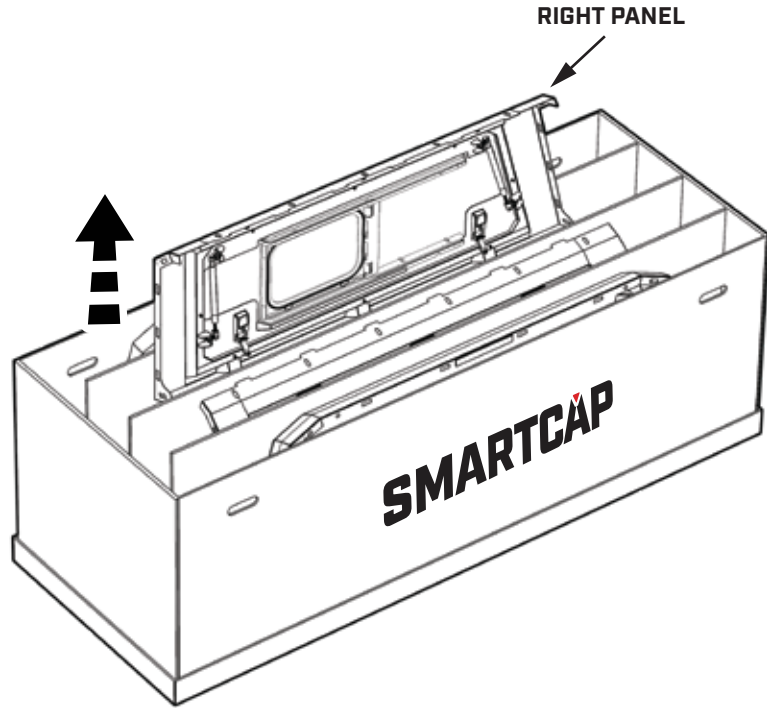

STEP 8

INSERT PANEL TABS INTO THE NARROW SLOTS JUST ABOVE FOAM PADDING ON ROOF PANEL.

TAP FIRMLY WITH PALM OF HAND UNTIL THERE IS A 2-3MM GAP.

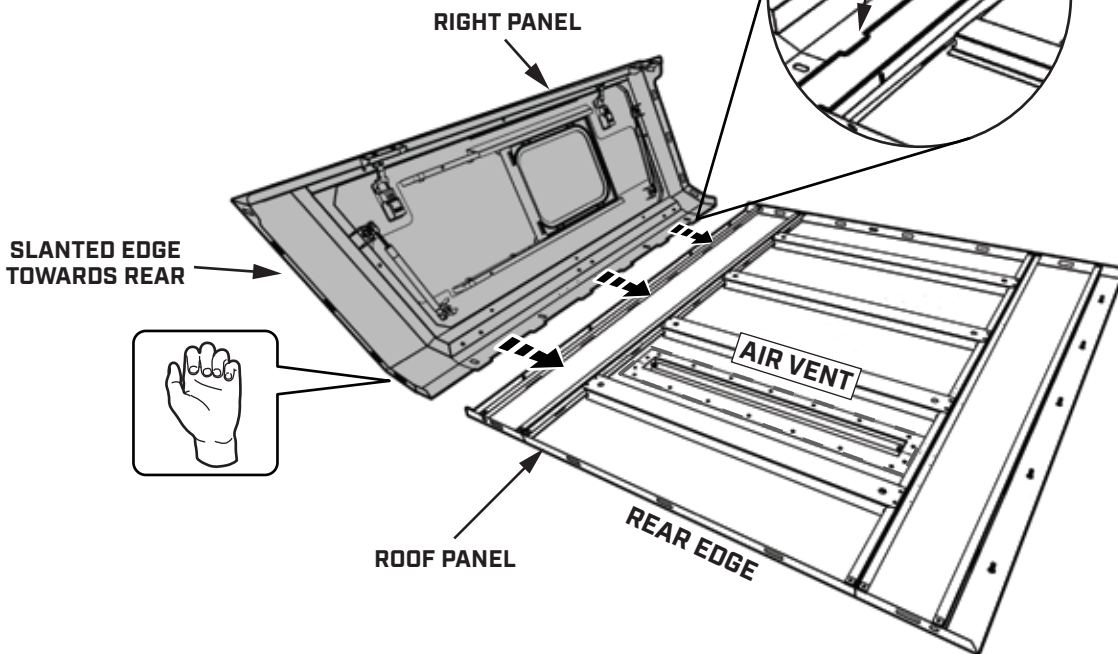
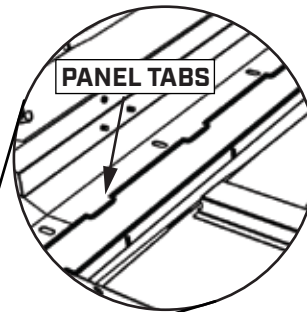

I-SHEET-ROW-R2

STEP 9

HAND TIGHTEN M6 LOCK NUT WITH M6 FENDER WASHER TO ALL BOLTS.



SUPPORT RIGHT PANEL UNTIL ASSEMBLED TO FRONT FLANGE

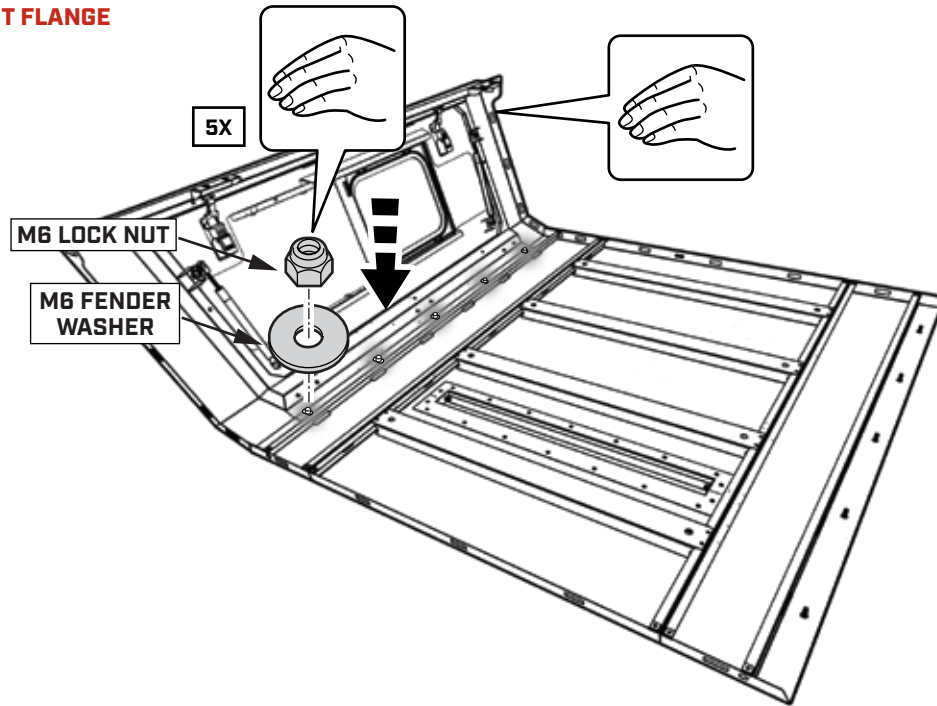

STEP 10

LOCATE THE FRONT FLANGE IN THE SMARTCAP PACKAGE AND BRING IT TO YOUR WORK AREA.

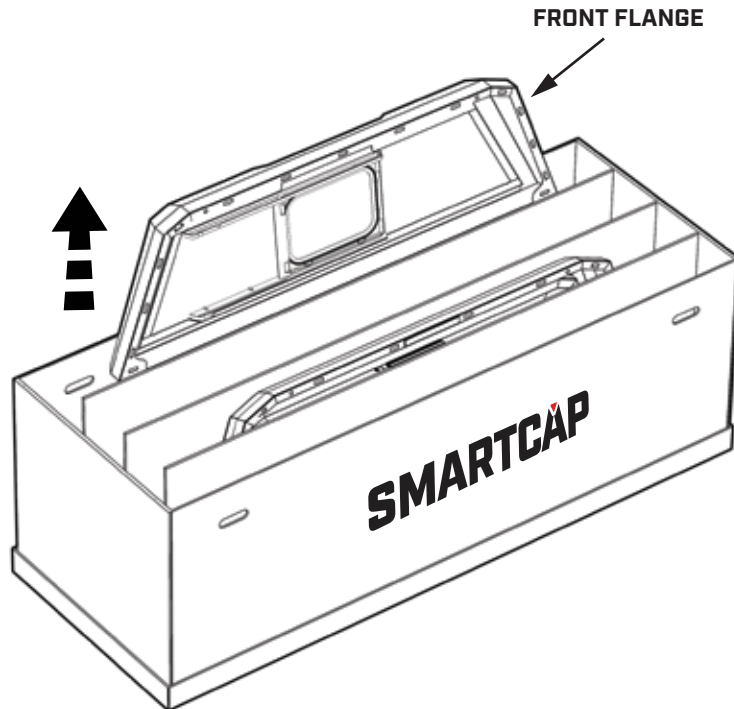

I-SHEET-ROW-R2

STEP 11

PLACE FRONT FLANGE AS SHOWN BELOW.

HAND TIGHTEN TWO FASTENER BLOCKS AT THE INDICATED LOCATIONS TO SUPPORT THE RIGHT PANEL AND FRONT FLANGE.

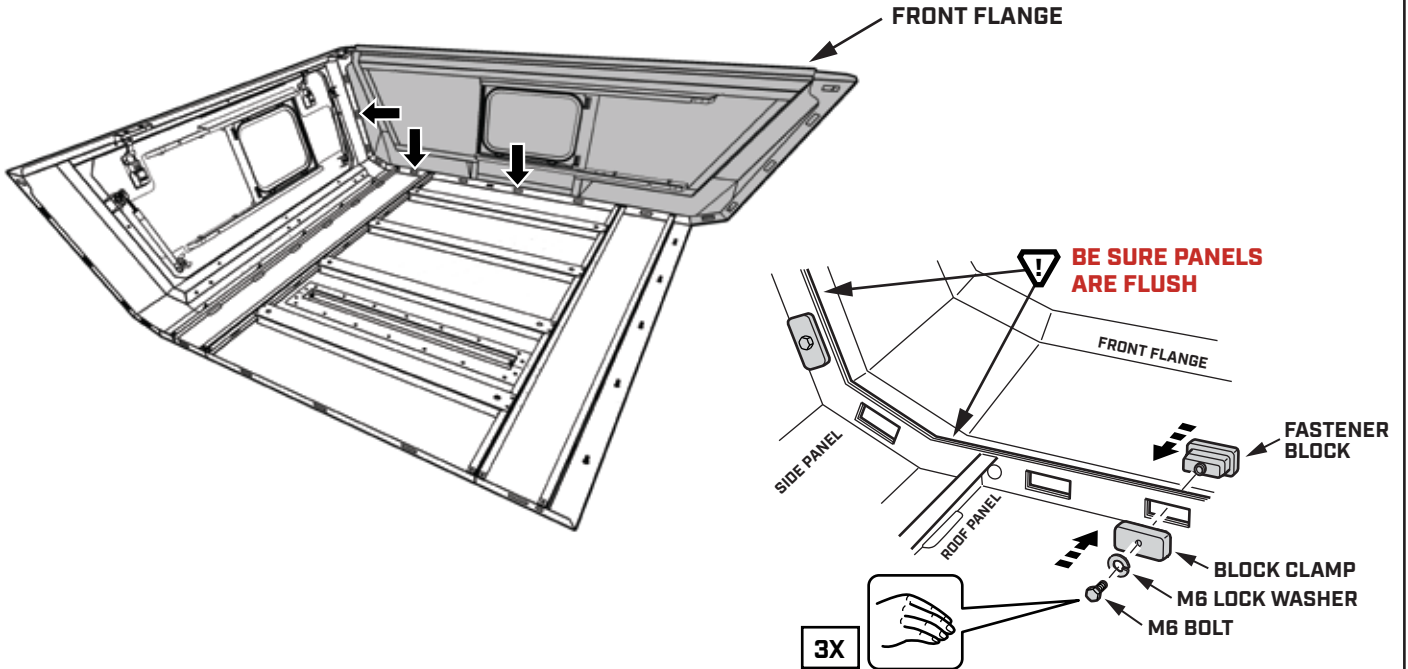

STEP 12

LOCATE THE LEFT PANEL IN THE SMARTCAP PACKAGE AND BRING IT TO YOUR WORK AREA.



 **SLANTED EDGE INDICATES REAR**

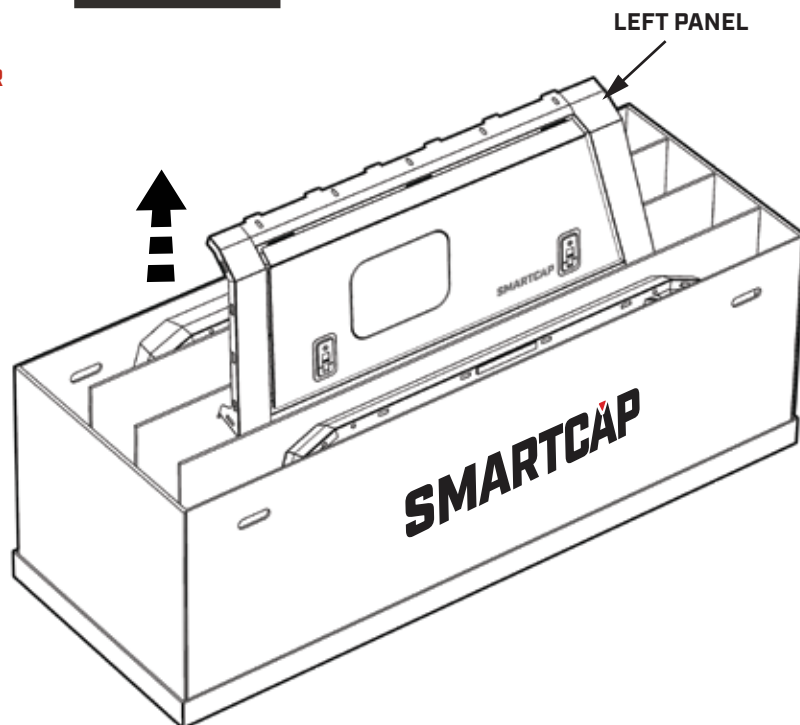
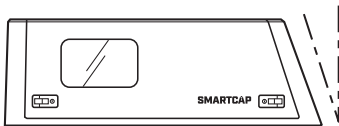

I-SHEET-ROW-R2

STEP 13

INSERT PANEL TABS INTO THE NARROW SLOTS JUST ABOVE FOAM PADDING ON ROOF PANEL.

TAP FIRMLY WITH PALM OF HAND UNTIL THERE IS A 2-3MM GAP.

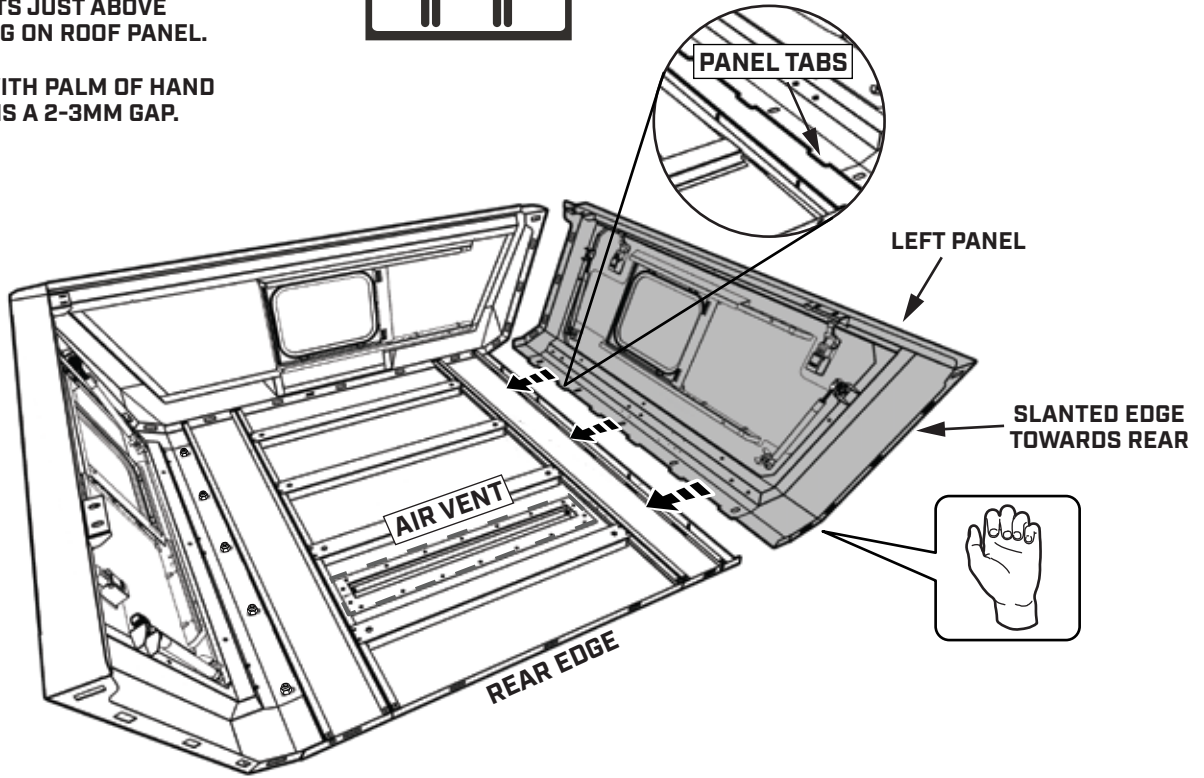

STEP 14

HAND TIGHTEN M6 LOCK NUT WITH M6 FENDER WASHER TO ALL BOLTS.

! SUPPORT LEFT PANEL UNTIL ASSEMBLED TO FRONT FLANGE

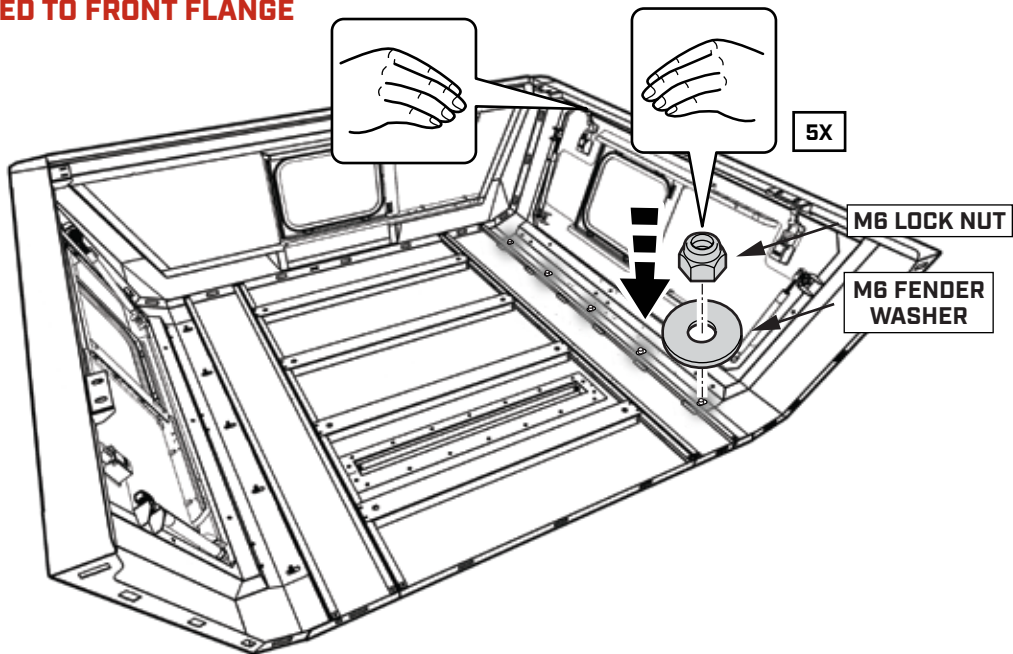

STEP 15

INSTALL HARDWARE ALONG FRONT FLANGE WITH BOLT ON INSIDE.

START AT CENTER OF THE FRONT FLANGE AND WORK YOUR WAY OUTWARDS.

ADJUST LEFT AND RIGHT PANELS TO ALIGN THE FASTENER BLOCK HOLES.

HAND TIGHTEN ONLY.

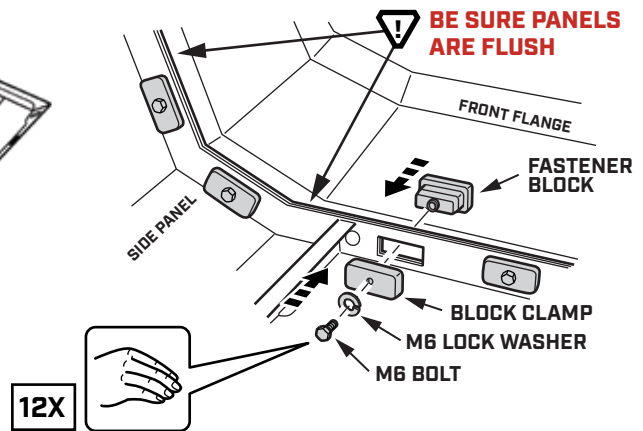
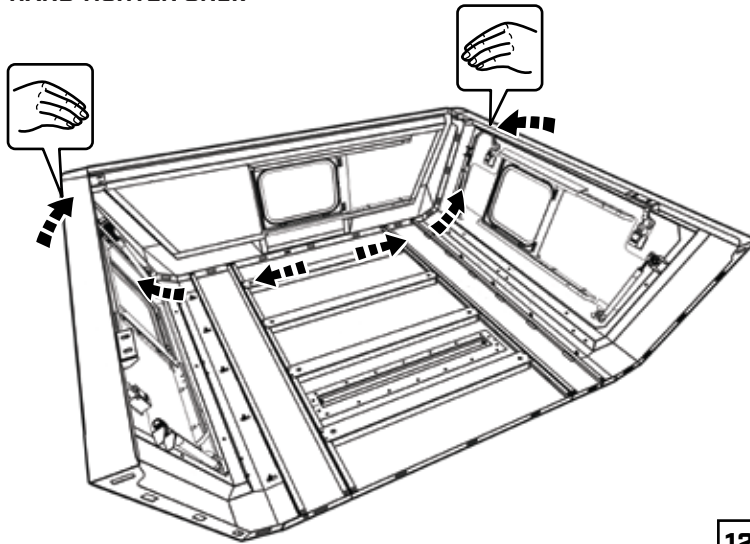

STEP 16

LOCATE THE REAR FLANGE IN THE SMARTCAP PACKAGE AND BRING IT TO YOUR WORK AREA.

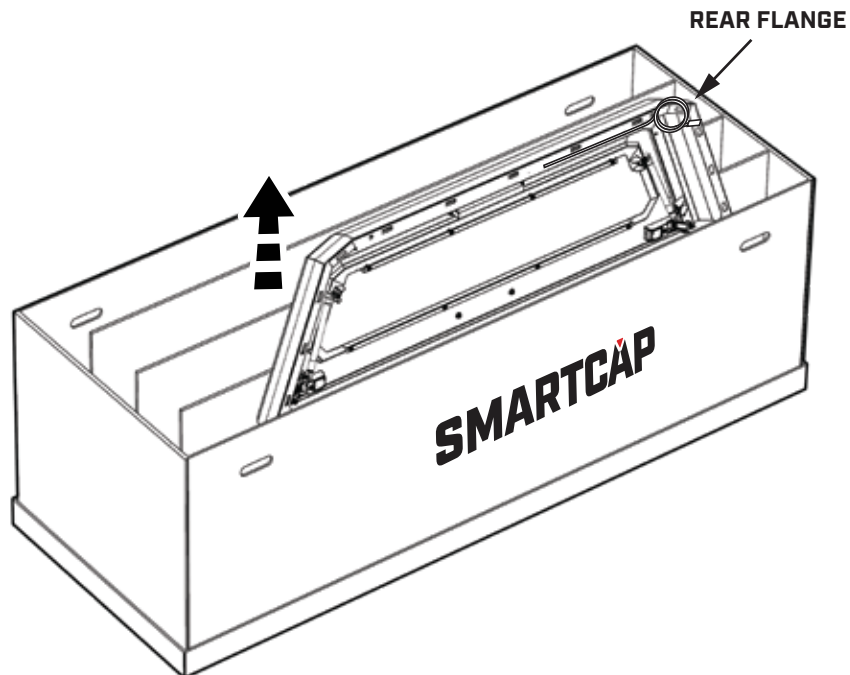

STEP 17

PLACE REAR FLANGE AS SHOWN BELOW.

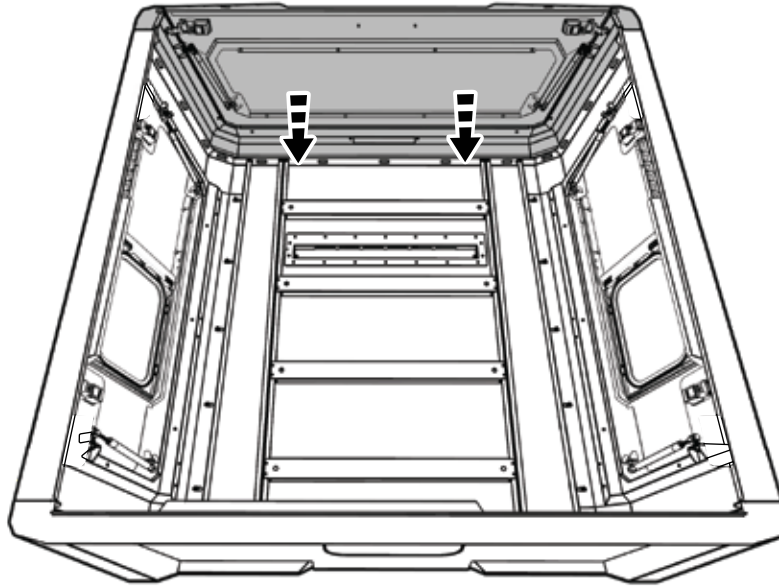

STEP 18

INSTALL HARDWARE ALONG REAR FLANGE WITH BOLT ON INSIDE.



START AT CENTER OF THE REAR FLANGE AND WORK YOUR WAY OUTWARDS.

ADJUST LEFT AND RIGHT PANELS TO ALIGN THE FASTENER BLOCK HOLES.

HAND TIGHTEN ONLY.

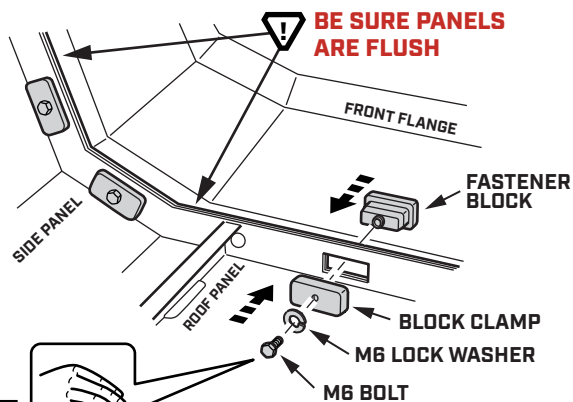

15X

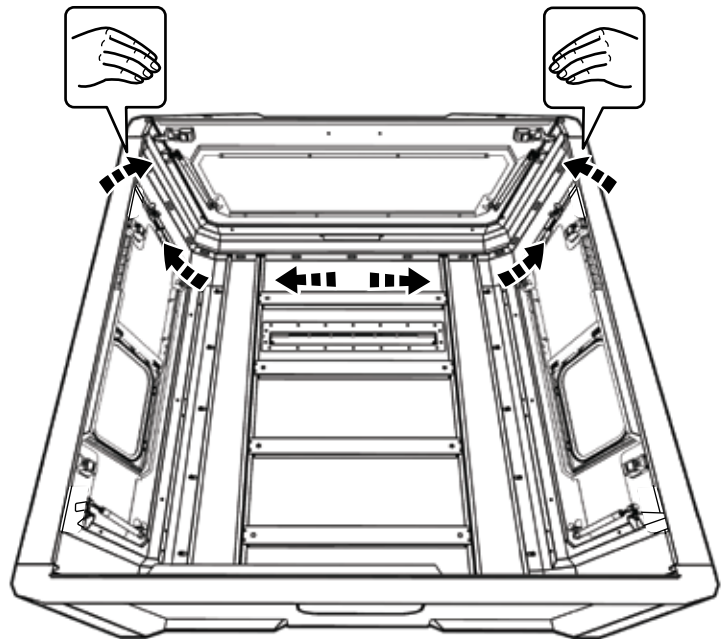

I-SHEET-ROW-R2

STEP 19

TIGHTEN ALL HARDWARE WITH TORQUE WRENCH AND 10MM SOCKET TO 3.7 FT. LBS. (5 NEWTON METERS)

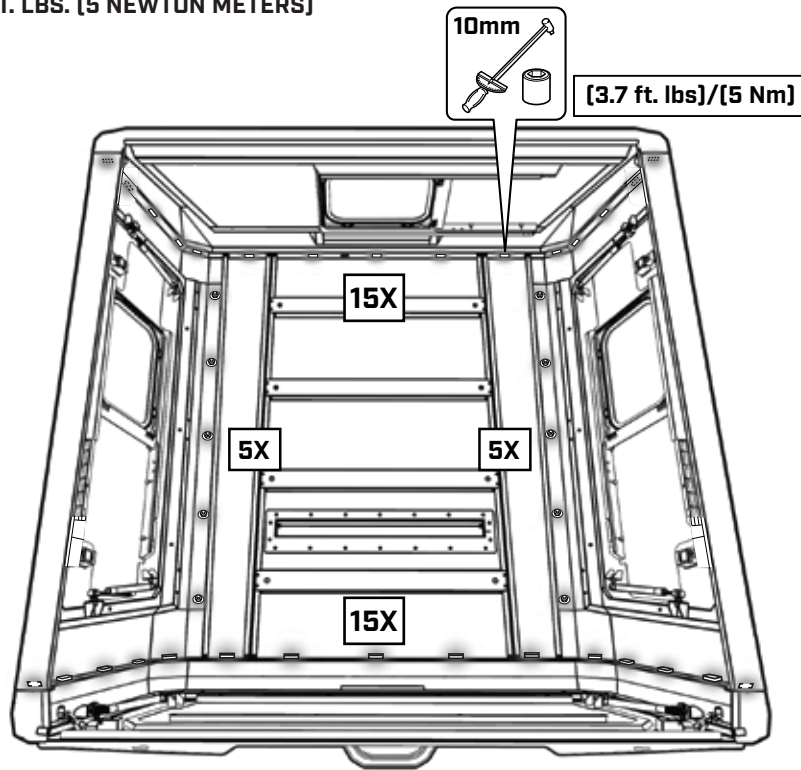

STEP 20

ENSURE THE ENTIRE BOTTOM EDGE OF THE SMARTCAP IS CLEAN.

LOCATE BOTH RETENTION TABS ON THE REAR FLANGE AND BEND EACH TO A 45-DEGREE ANGLE FOR D-RUBBER FITMENT.

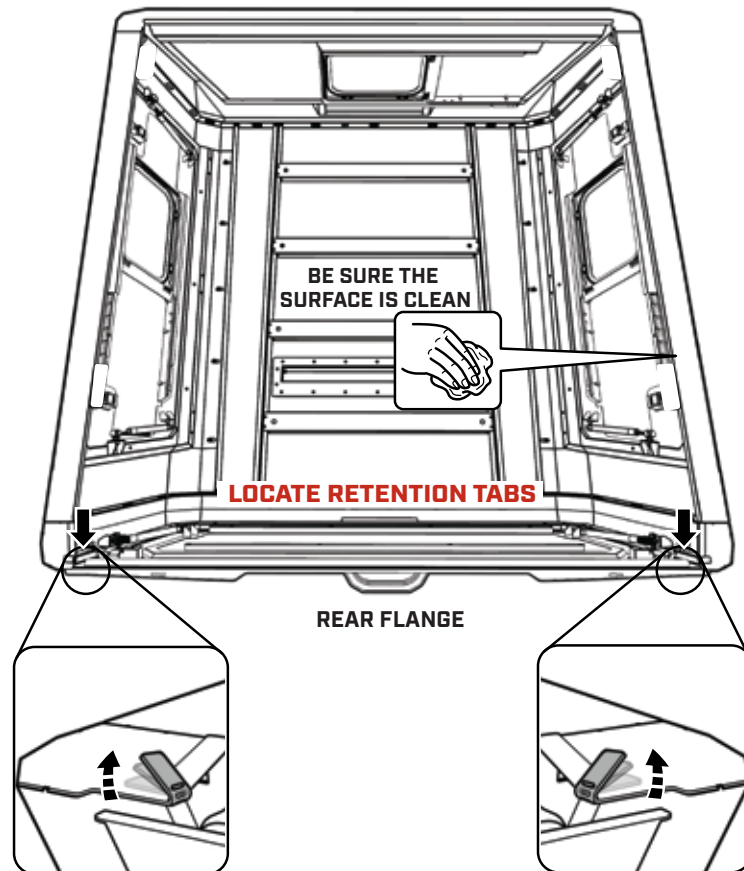

STEP 21



TRIM THE D-RUBBER WITH A CLEAN, STRAIGHT CUT.

APPLY 2-3 INCHES SUPER GLUE NEAR THE RETENTION TABS, ALONG THE BOTTOM EDGE OF THE REAR FLANGE

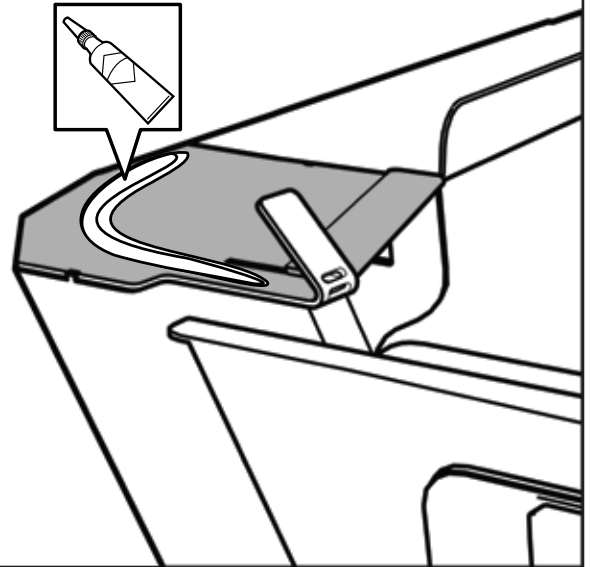
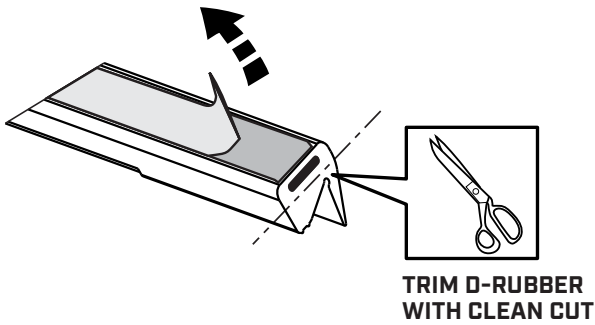

STEP 22

FULLY INSERT THE RETENTION TAB INTO THE SLOT ON THE D-RUBBER. ENSURE THE D-RUBBER IS ORIENTED CORRECTLY WITH ITS PROFILE MATCHING THE CONTOUR OF THE REAR FLANGE.

PRESS DOWN FIRMLY ON THE TAB AND THE D-RUBBER TO BOND IT TO THE REAR FLANGE, CREATING A TIGHT SEAL.

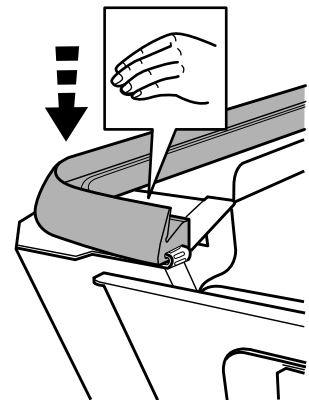
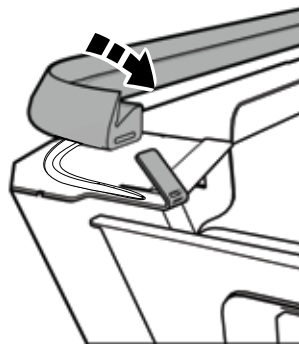

CORRECT D-RUBBER ORIENTATION

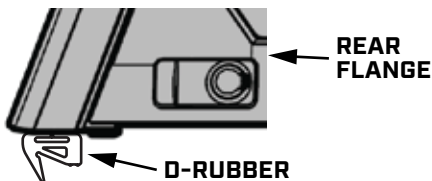

INCORRECT D-RUBBER ORIENTATION

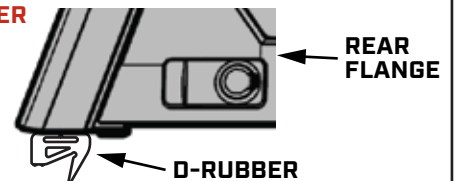

I-SHEET-ROW-R2

STEP 23

ALIGN THE D-RUBBER ALONG THE SMARTCAP'S EDGE, MAINTAINING A CONSISTENT 1/8 INCH GAP FROM THE EDGE.

START FROM ONE CORNER AND WORK YOUR WAY AROUND THE CAP TO ENSURE PROPER PLACEMENT AND ALIGNMENT.

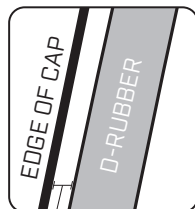

1/8 INCH
FROM EDGE

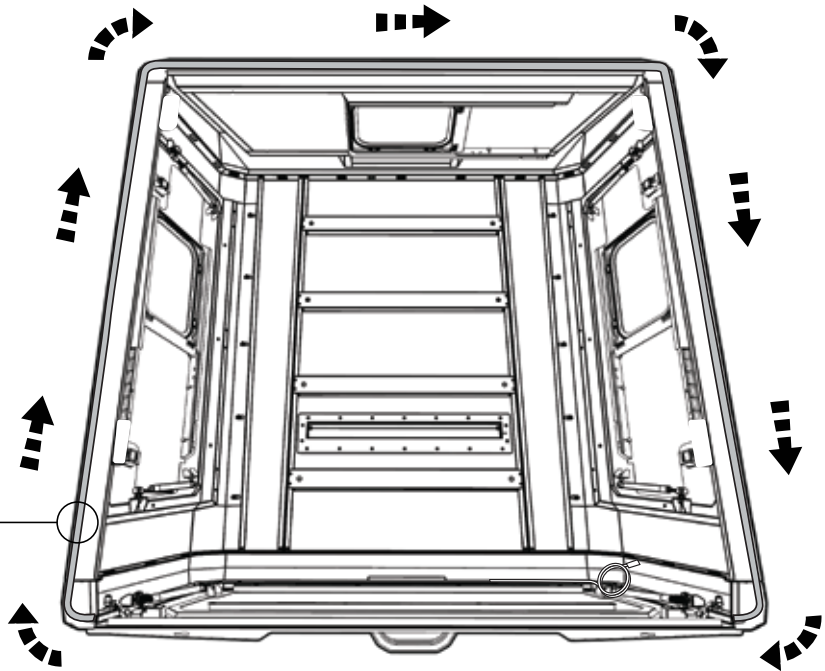

STEP 24

TRIM ANY EXCESS D-RUBBER BEYOND THE EDGE FOR A NEAT FINISH.

APPLY 2-3 INCHES OF SUPER GLUE NEAR THE RETENTION TAB, ALONG THE BOTTOM EDGE OF THE REAR FLANGE. FULLY INSERT THE RETENTION TAB INTO THE SLOT ON THE D-RUBBER.

PRESS DOWN FIRMLY ON THE TAB AND THE D-RUBBER TO BOND IT TO THE REAR FLANGE, CREATING A TIGHT SEAL.

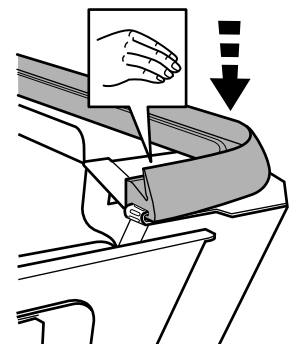
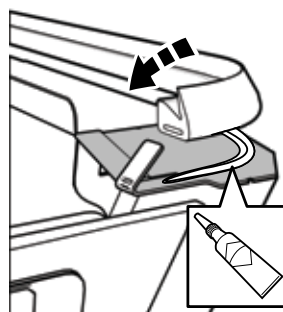
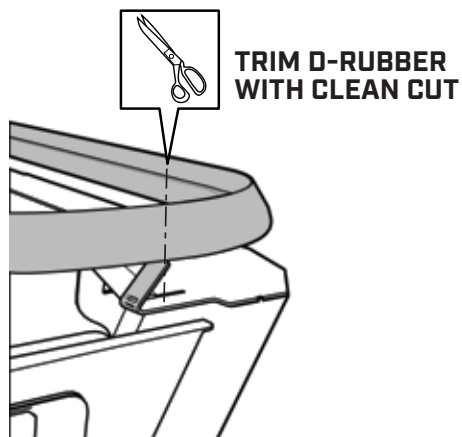

I-SHEET-ROW-R2

FRONT MOUNTING BRACKETS

INSTALLATION HARDWARE

MOUNTING BRACKETS

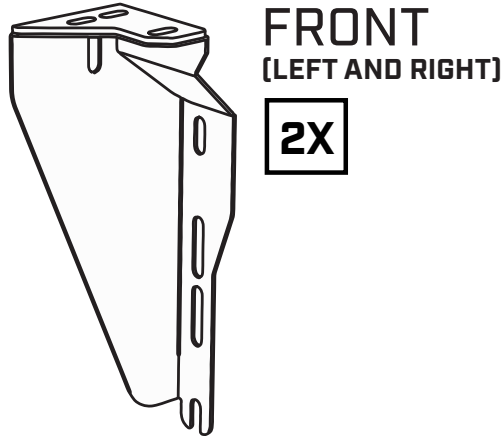
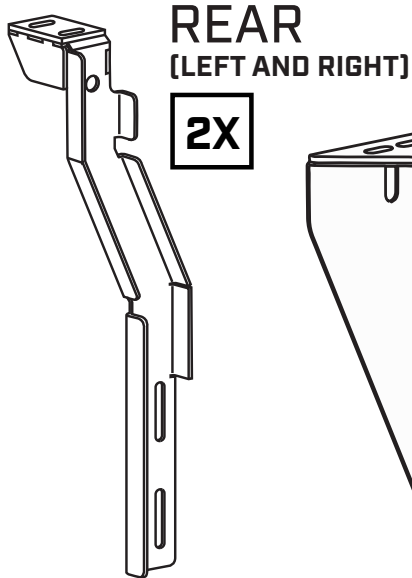

25mm x 25mm FOAM SEAL TAPE

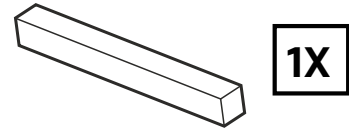

M8 LOCK NUT



M8 x 20mm BOLT



M8 FENDER WASHER



M8 LOCK WASHER



M6 x 20mm BOLT

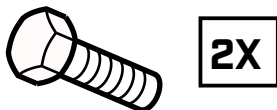

M6 FENDER WASHER



M6 LOCK WASHER



VEHICLE INSTALLATION



IMPORTANT

- ▼ ASSISTANCE WILL BE NEEDED FOR THIS INSTALLATION. FOUR PEOPLE ARE RECOMMENDED TO LIFT THE SMARTCAP ONTO THE VEHICLE.
- ▼ AVOID PINCHING OR CRUSHING HANDS AND FINGERS.
- ▼ READ THROUGH THE ENTIRE PROCEDURE BEFORE STARTING.

I-SHEET-ROW-R2

STEP 25

INSPECT THE TRUCK BED. IF FRONT EDGE IS LOWER THAN THE SIDES, ADD FOAM SEAL TAPE TO THE FRONT EDGE OF THE BED.

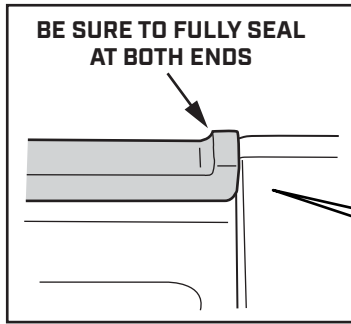
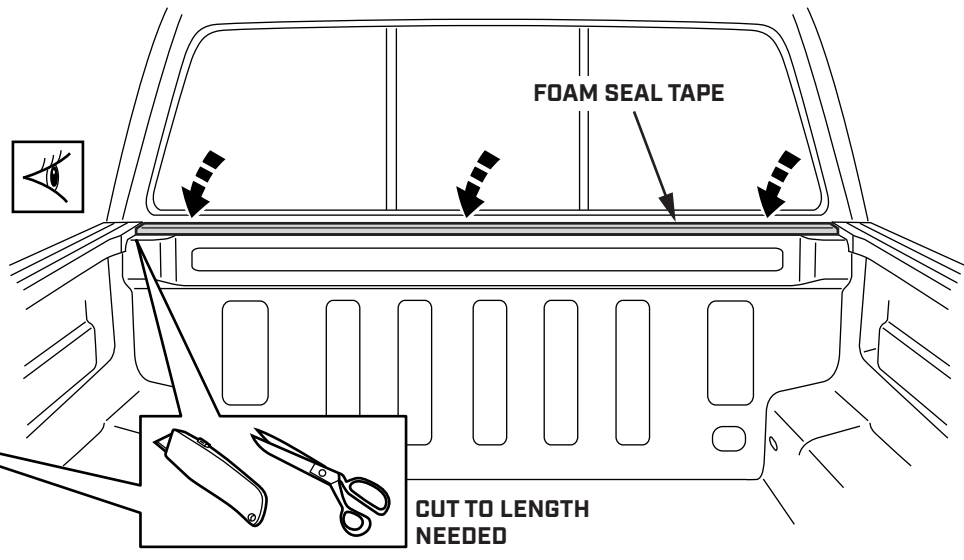
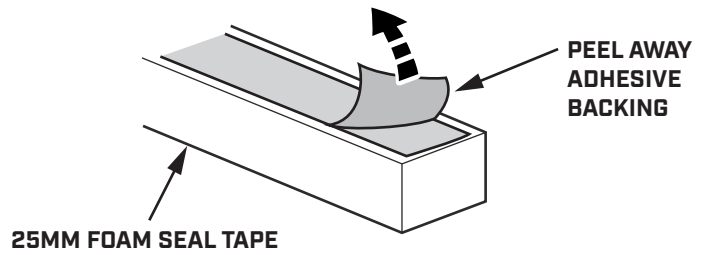

STEP 26

REMOVE THE FRONT TIE DOWN HOOK FROM THE INNER WALL OF THE TRUCK BED.

HAND TIGHTEN BOTH FRONT BRACKETS TO TRUCK BED WITH M8 BOLT, M8 LOCK WASHER, TIE DOWN HOOK, TIE DOWN BRACKET AND M8 FENDER WASHER AS SHOWN.

REPEAT ON THE OPPOSITE SIDE OF THE VEHICLE WITH THE LEFT FRONT MOUNTING BRACKET.

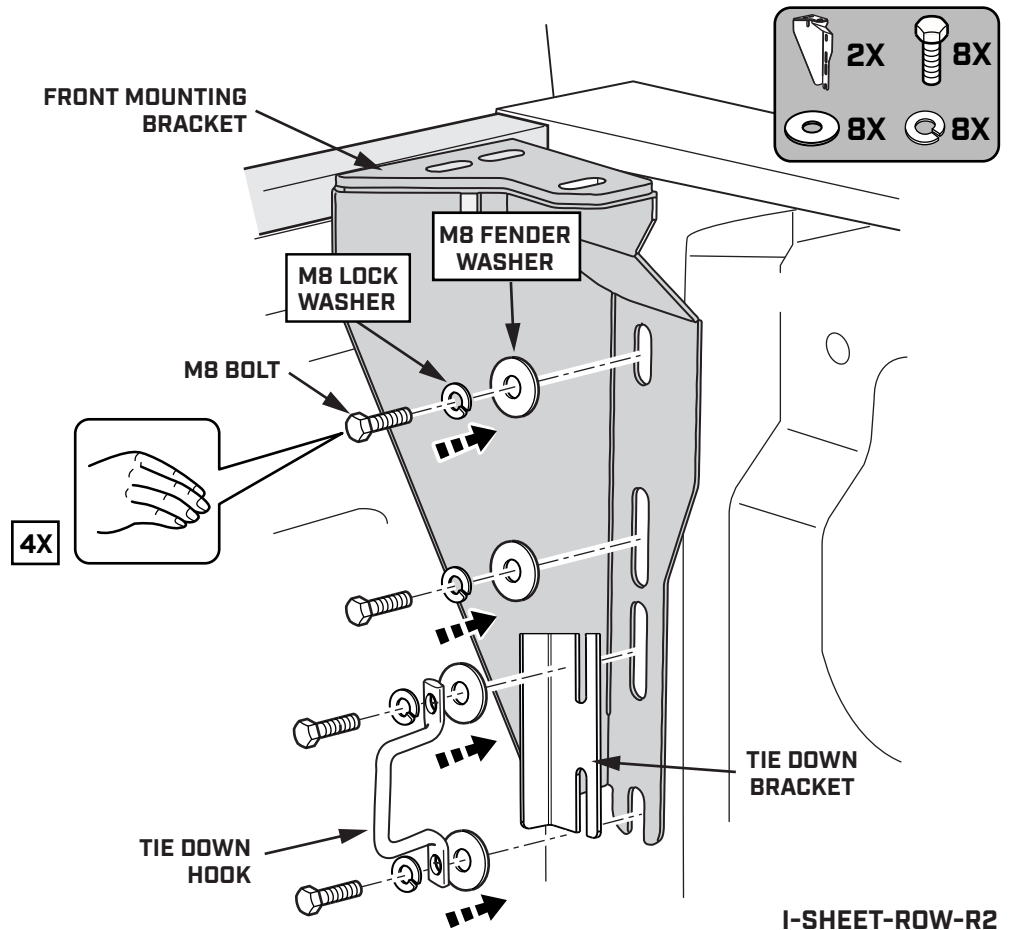

I-SHEET-ROW-R2

STEP 27

WITH THE REMAINING BOLT LOCATION, HAND TIGHTEN BOTH FRONT BRACKETS TO TRUCK BED WITH M6 BOLT, M6 LOCK WASHER, TIE DOWN HOOK, TIE DOWN BRACKET AND M6 FENDER WASHER AS SHOWN.

REPEAT ON THE OPPOSITE SIDE OF THE VEHICLE WITH THE LEFT FRONT MOUNTING BRACKET.

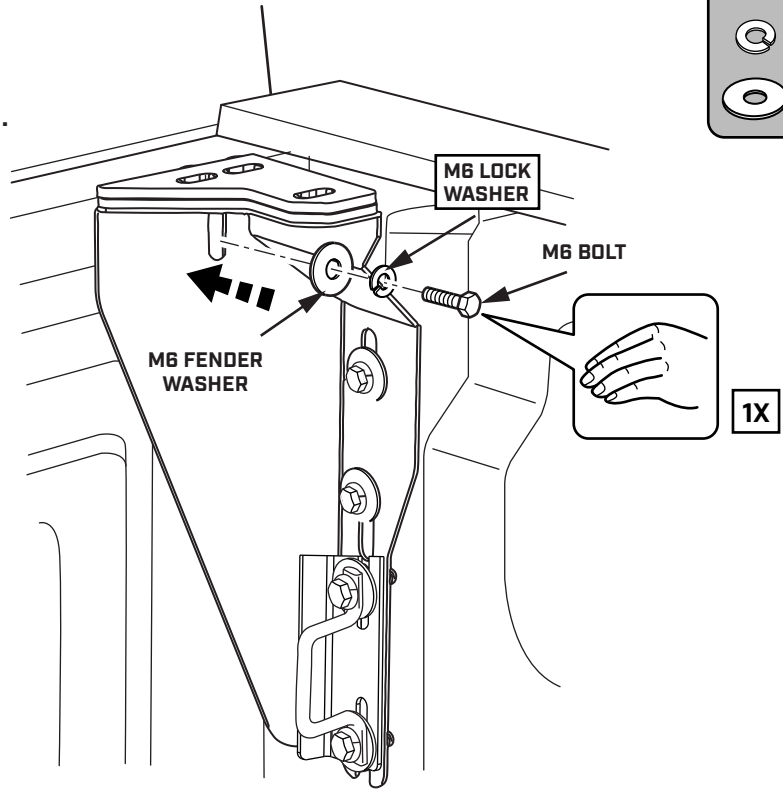

STEP 28

REMOVE THE REAR TIE DOWN HOOK FROM THE INNER WALL OF THE TRUCK BED.

HAND TIGHTEN BOTH REAR BRACKETS TO TRUCK BED WITH M8 BOLT, M8 LOCK WASHER, TIE DOWN HOOK AND M8 FENDER WASHER AS SHOWN.

REPEAT ON THE OPPOSITE SIDE OF THE VEHICLE WITH THE LEFT REAR MOUNTING BRACKET.

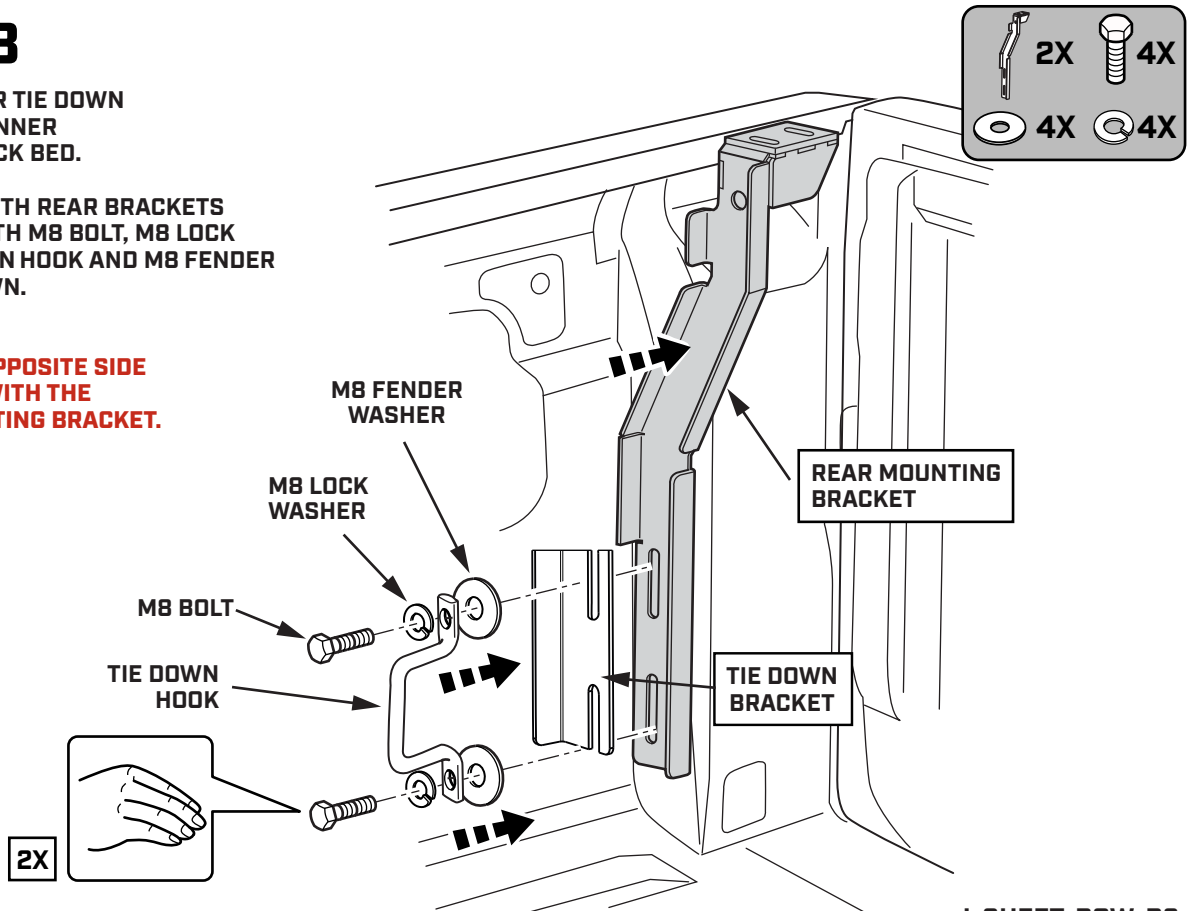

I-SHEET-ROW-R2

STEP 29

USE 4 PEOPLE TO LIFT THE ASSEMBLED SMARTCAP ONTO THE TRUCK BED.

TO AVOID DAMAGE TO THE D-RUBBER, DO NOT SLIDE THE SMARTCAP INTO PLACE.

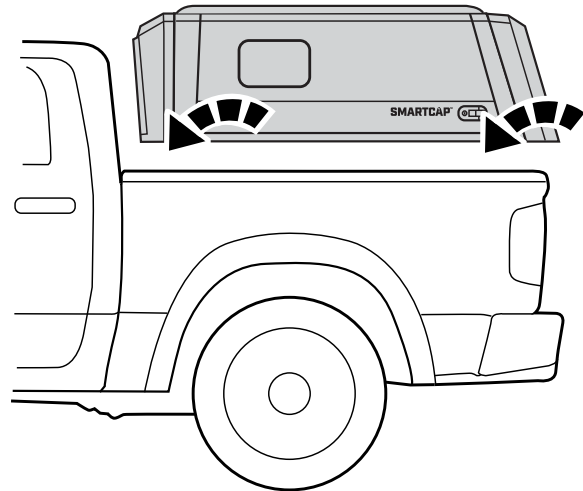

STEP 30

CHECK THAT THE SMARTCAP IS PROPERLY POSITIONED AND CENTERED ON THE TRUCK BED.

IT'S IMPORTANT THAT THE SMARTCAP IS NOT PUSHED TOO FAR FORWARD, LEAVING A GAP BETWEEN THE SMARTCAP AND THE CAB.

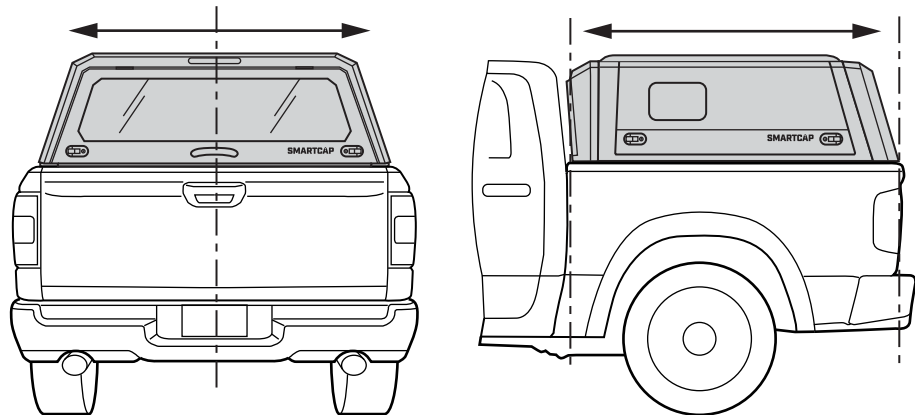
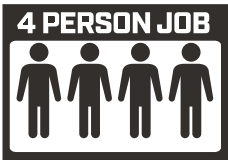

STEP 31

WALK AROUND THE TRUCK BED TO MAKE SURE THE D-RUBBER FITMENT IS CORRECT AND THAT THE RUBBER LIP IS PROPERLY TUCKED UNDERNEATH THE CAP.

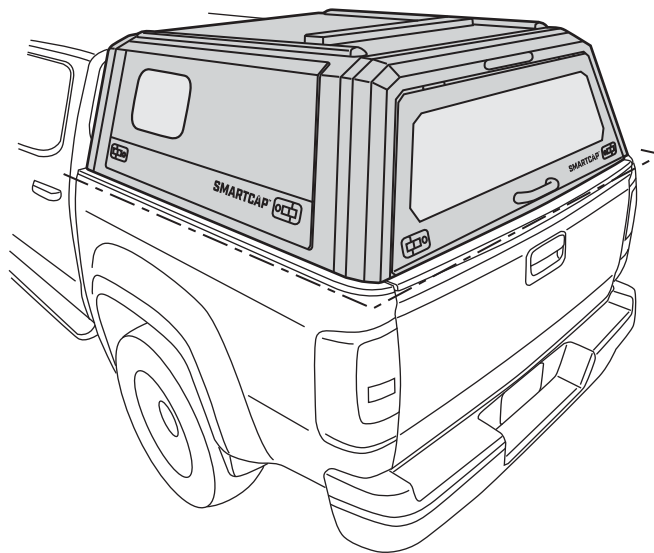

**YOU MAY NOTICE THAT THE SEAL ON THE SLIDING PORTAL WINDOW MIGHT APPEAR WRINKLED. THIS IS DUE TO THE ANTI-SLIP COATING AND IS NOT A CAUSE FOR CONCERN.*

I-SHEET-ROW-R2

STEP 32

SECURE BOTH FRONT BRACKETS TO THE SMARTCAP WITH M8 BOLTS, M8 FENDER WASHERS AND M8 LOCK NUT AS SHOWN, HAND TIGHTEN ONLY

REPEAT ON THE OPPOSITE SIDE OF THE VEHICLE WITH THE LEFT FRONT MOUNTING BRACKET.

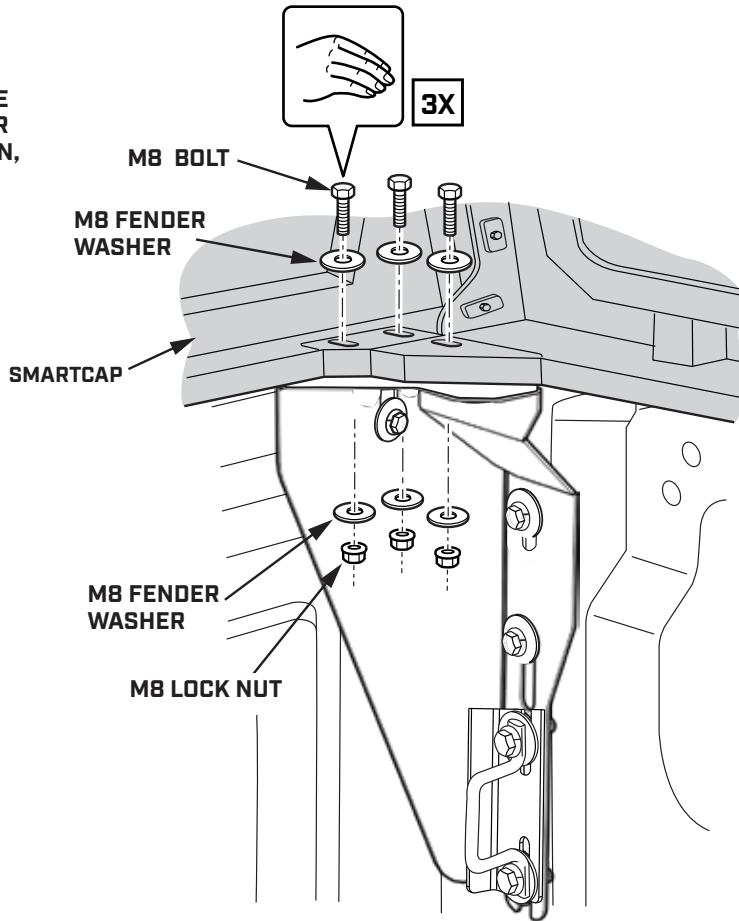

- 6X
- 12X
- 6X

STEP 33

SECURE BOTH REAR BRACKETS TO THE SMARTCAP USING M8 BOLTS, M8 FENDER WASHERS AND M8 LOCK NUT AS SHOWN, HAND TIGHTEN ONLY.

REPEAT ON THE OPPOSITE SIDE OF THE VEHICLE WITH THE LEFT REAR MOUNTING BRACKET.

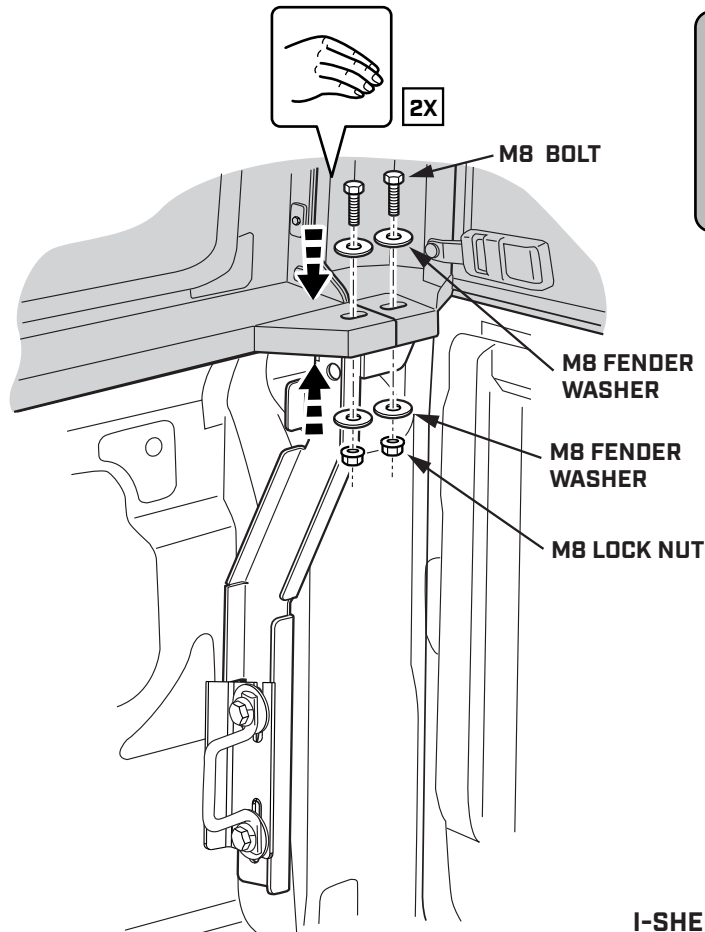

- 4X
- 8X
- 4X

STEP 34

PARTIALLY TIGHTEN FASTENERS FOR ALL FOUR MOUNTING BRACKETS USING THE SOCKET WRENCH AND 13MM SOCKET.

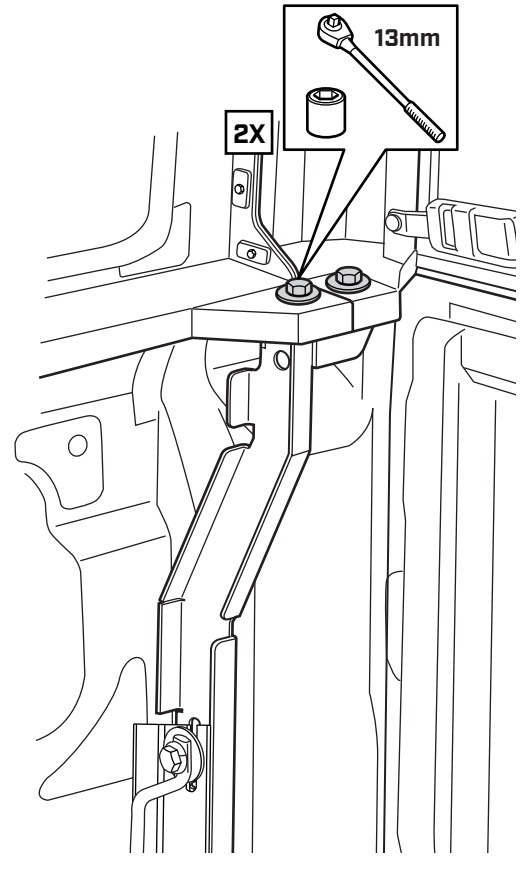
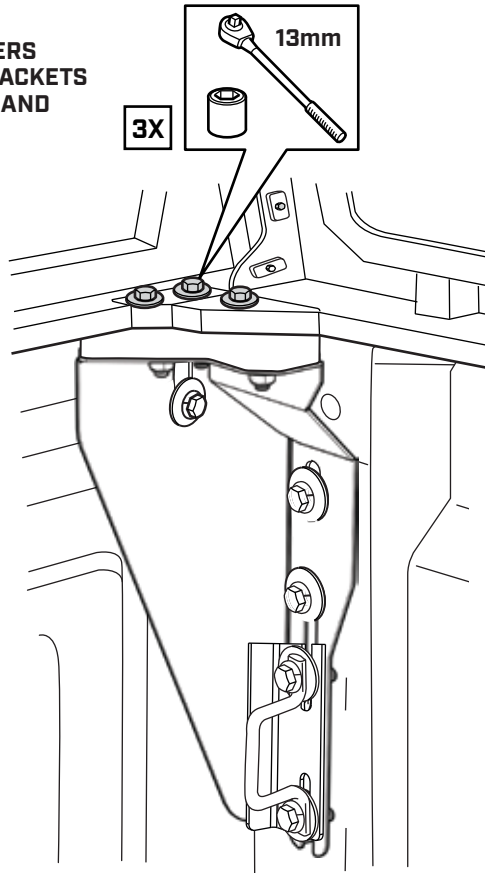

STEP 35

PRESS DOWN ON SMARTCAP TO ACHIEVE 2MM - 3MM COMPRESSION ON D-RUBBER AND PARTIALLY TIGHTEN FRONT BRACKET FASTENERS WITH SOCKET WRENCH AND 13MM SOCKET.

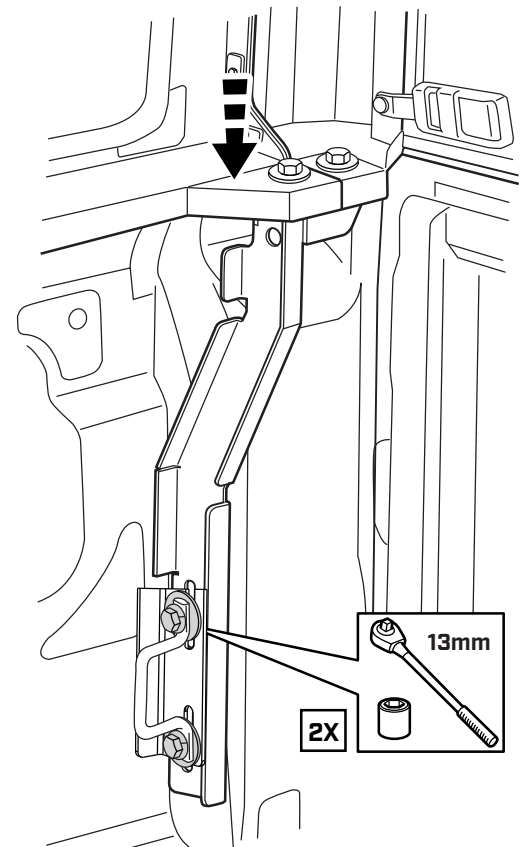
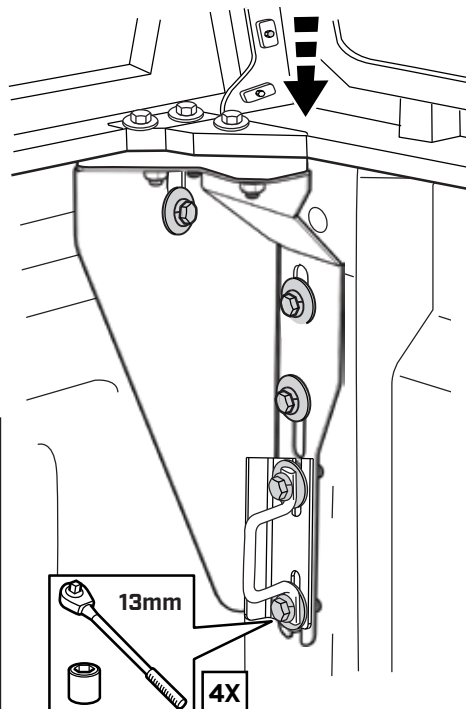
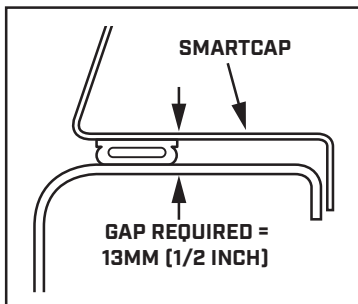

STEP 36

FULLY TIGHTEN ALL BRACKET FASTENERS WITH TORQUE WRENCH AND 13MM SOCKET TO 4.4 FT. LBS. OF TORQUE [6 NEWTON METERS]

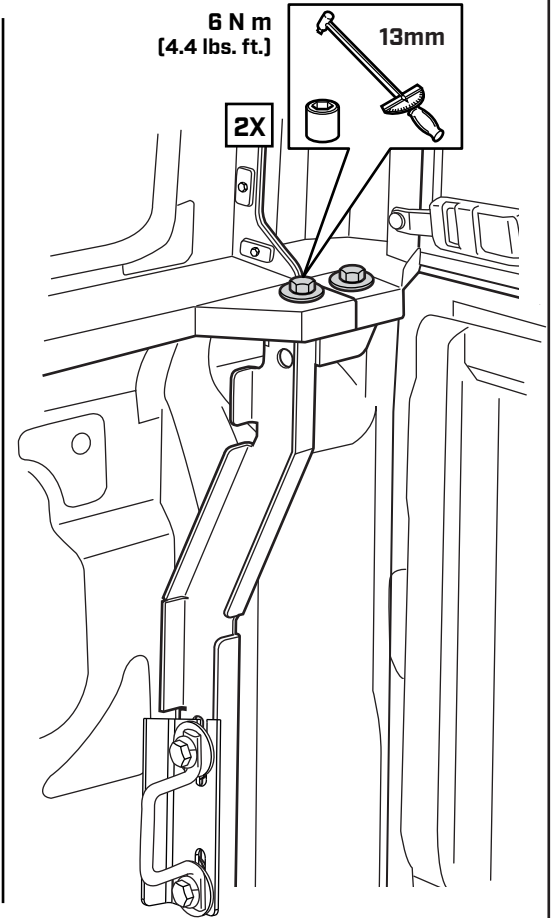
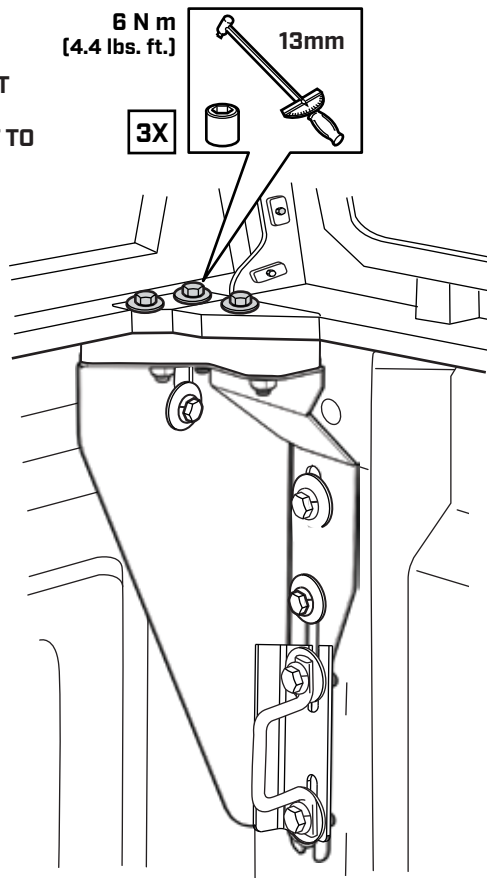

STEP 37

FULLY TIGHTEN ALL BRACKET FASTENERS WITH TORQUE WRENCH AND 13MM SOCKET TO 9 FT. LBS. OF TORQUE [12.2 NEWTON METERS]

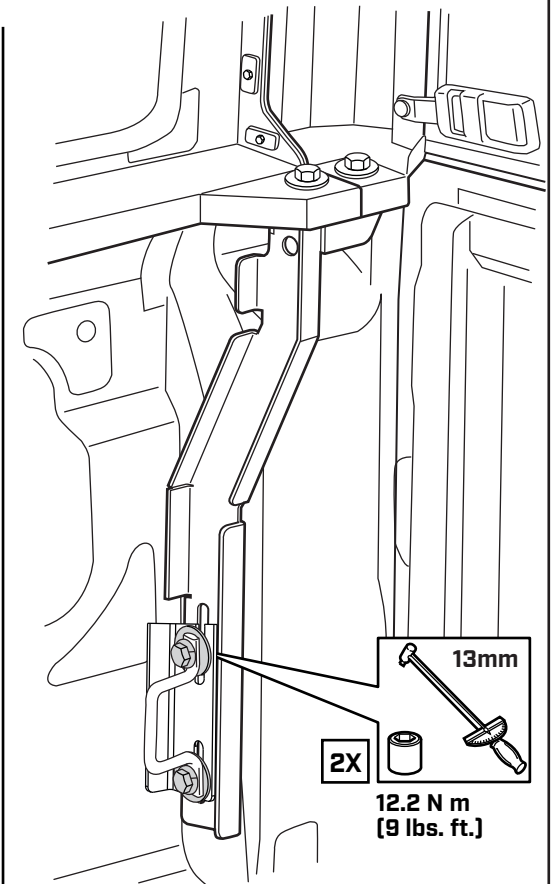
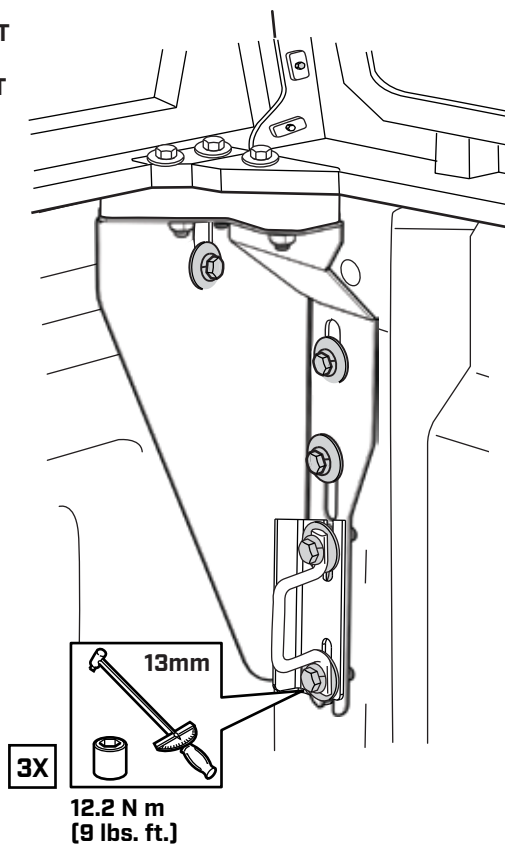

I-SHEET-ROW-R2

THIRD BRAKE LIGHT CONNECTOR INSTALLATION



IMPORTANT

- ▼ BE SURE THE VEHICLE IS TURNED OFF FOR THIS INSTALLATION.
- ▼ READ THROUGH THE ENTIRE PROCEDURE BEFORE STARTING AND FOLLOW THE STEPS CAREFULLY TO ENSURE THE THIRD BRAKE LIGHT AND TRAILER PLUG WILL FUNCTION PROPERLY.
- ▼ USE A TEST LIGHT TO CHECK FOR SUCCESSFUL INSTALLATION.

STEP 38

REMOVE THE LEFT SIDE
TAIL LIGHT ASSEMBLY.

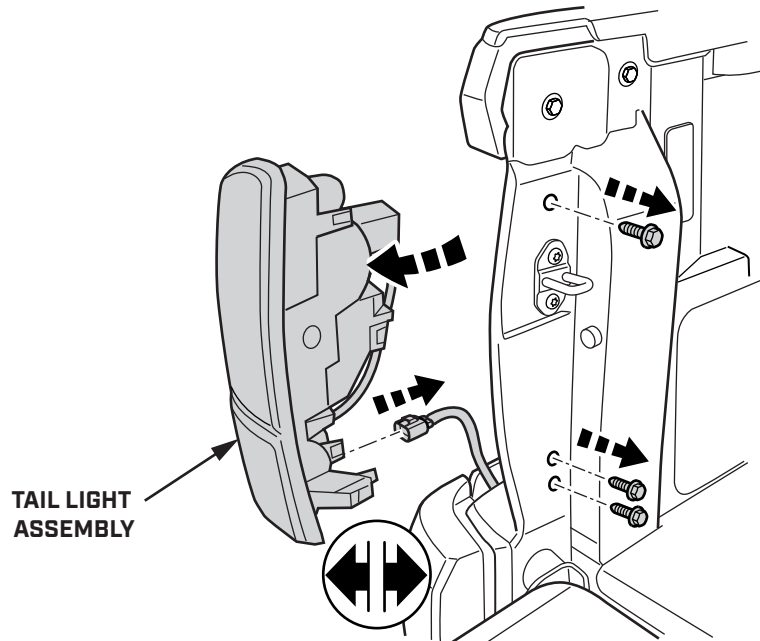

STEP 39

LOCATE THE THIRD BRAKE LIGHT 2-PIN
PLUG INSIDE THE BACK LEFT CORNER
OF THE SMARTCAP.

CONNECT THE NEW T-HARNESS
TO THE 2-PIN PLUG.

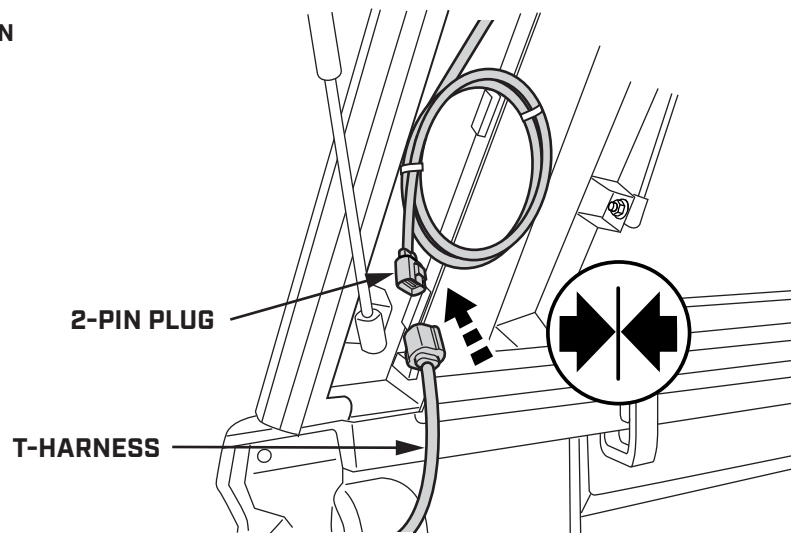

I-SHEET-ROW-R2

STEP 40

REMOVE THE GROMMET COVER
AT THE TRUCK BED WALL.

ROUTE THE T-HARNESS IN THROUGH
THE GROMMET PANEL OPENING AND OUT
THROUGH THE TAIL LAMP OPENING.

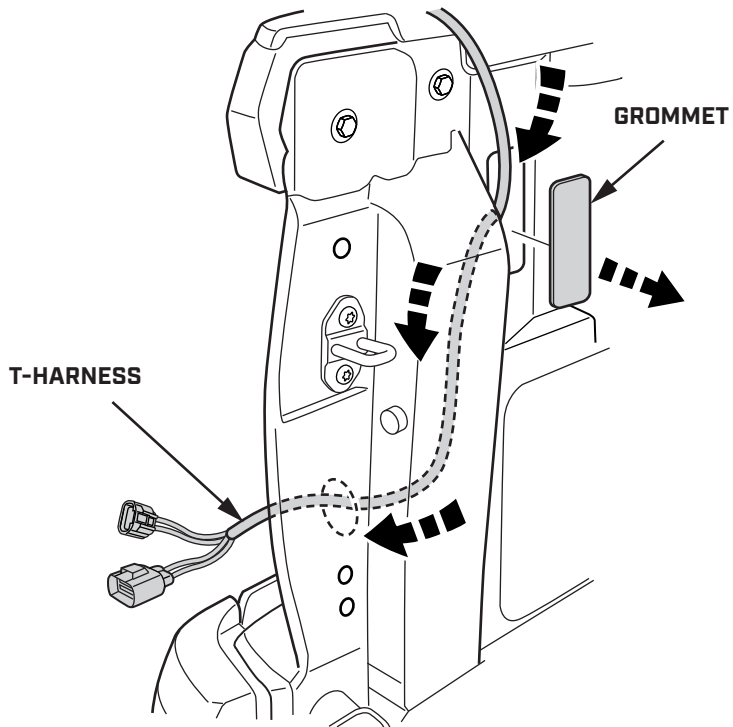

STEP 41

CONNECT THE BRAKE LIGHT PLUG INTO
THE FEMALE PLUG FROM THE T-HARNESS.

CONNECT THE MALE PLUG FROM THE
T-HARNESS INTO THE TAIL LIGHT
BRAKE LIGHT SOCKET.

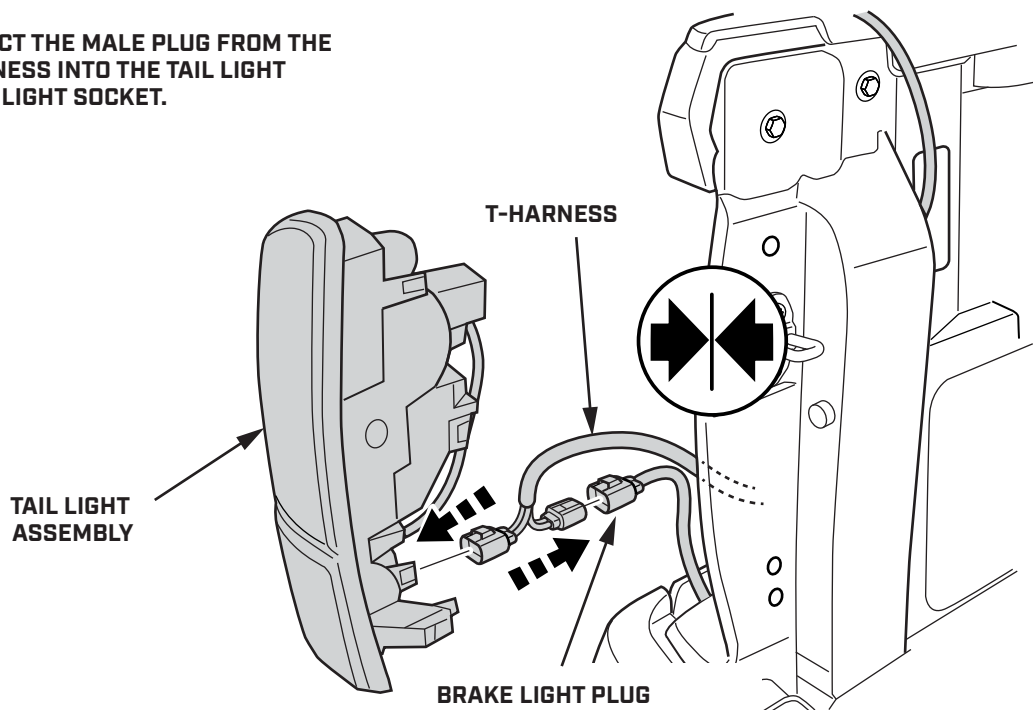

I-SHEET-ROW-R2

STEP 42

START THE TRUCK. NOTE THAT ON SOME MODELS, IT MAY TAKE UP TO 30 SECONDS FOR THE VEHICLE TO DETECT THE NEW CONNECTION.

CHECK THE BRAKE LIGHTS AND TURN SIGNALS TO BE SURE THEY ARE FUNCTIONING PROPERLY.

ONCE YOU HAVE CONFIRMED THAT THE LIGHTS ARE WORKING CORRECTLY, SECURE THE HARNESS WITH CABLE TIES. **BE SURE NOT TO INTERFERE WITH ANY MOVING PARTS ON THE VEHICLE.**

REINSTALL THE TAIL LIGHT ASSEMBLY.

REINSTALL THE TRUCK BED GROMMET.

BUNDLE EXTRA T-HARNESS CABLE LENGTH IN THE TAIL LIGHT CAVITY AND SECURE WITH A CABLE TIE.

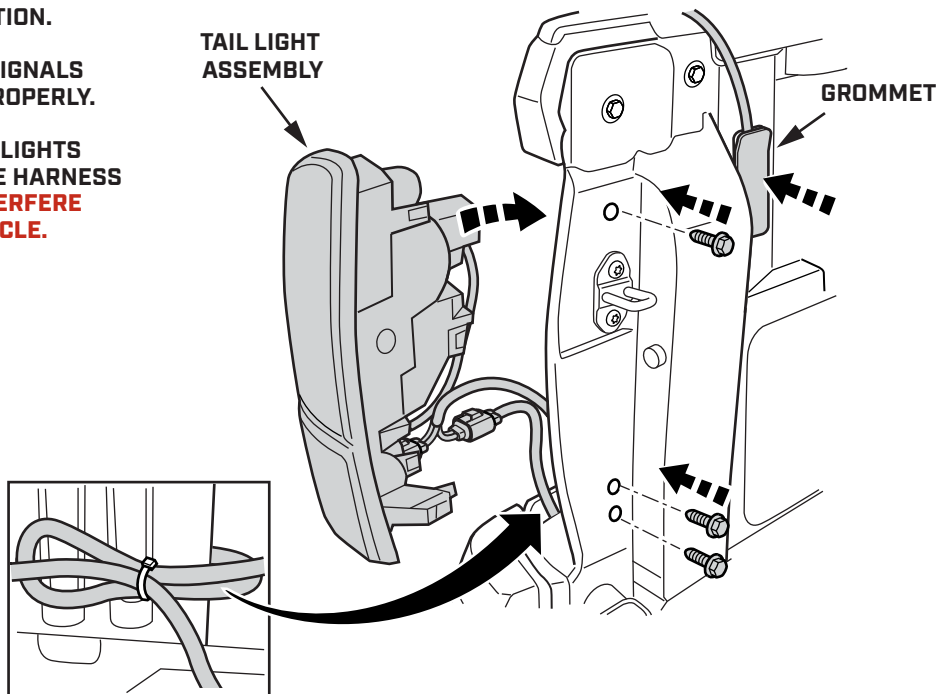

THANKS FOR YOUR PURCHASE.
PLEASE LET US KNOW IF YOU HAVE ANY QUESTIONS.

SMARTCAP.COM

SUPPORT.NA@SMARTCAP.COM - NORTH AMERICA

SUPPORT.SA@SMARTCAP.COM - REST OF WORLD



I-SHEET-ROW-R2