

SMARTCAP®

INSTRUCTION GUIDE

FORD RANGER EDITION

NEW GENERATION 2023-2024

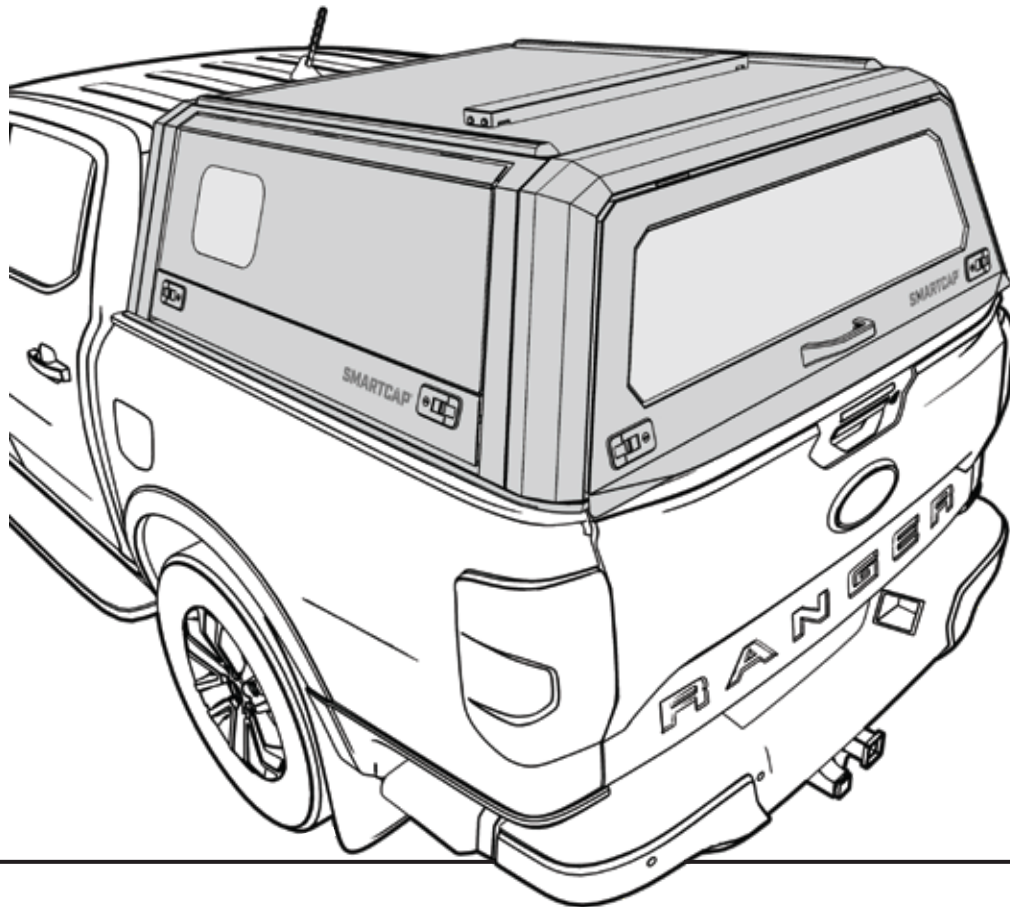

- ▼ **PREPARE A CLEAN WORK AREA.**
- ▼ **WE RECOMMEND A MINIMUM OF 2 PEOPLE FOR ASSEMBLY AND 4 PEOPLE FOR INSTALLATION**
- ▼ **ENSURE THE REQUIRED TOOLS ARE PRESENT AND ALL HARDWARE CONTENTS ARE ACCOUNTED FOR.**
- ▼ **NEVER USE ACETONE OR THINNERS ON PAINTED PARTS.**
- ▼ **READ THROUGH THE ENTIRE INSTRUCTION GUIDE BEFORE STARTING THIS PROCEDURE AND FOLLOW THE STEPS CAREFULLY TO AVOID ANY DAMAGE TO THE COMPONENTS OR THE VEHICLE.**

SMARTCAP.COM
SUPPORT.SA@SMARTCAP.COM - REST OF WORLD
SUPPORT.NA@SMARTCAP.COM - NORTH AMERICA/CANADA





DISCLAIMER

IT IS A REQUIREMENT FROM FORD THAT ANY 2024 NEXT GEN RANGER WITH ACCESSORIES EXTENDING ABOVE THE BEDRAILS, AND WEIGHING IN EXCESS OF 99LBS, BE FITTED WITH THEIR LOAD BOX REINFORCEMENT BRACKETS (AKA J-BRACES) PRIOR TO INSTALLATION, TO AVOID NEGATIVELY IMPACTING YOUR VEHICLE'S FACTORY WARRANTY. PLEASE CONSULT YOUR OWNER'S MANUAL OR SELLING DEALER FOR MOR INFORMATION.

TOOLS REQUIRED

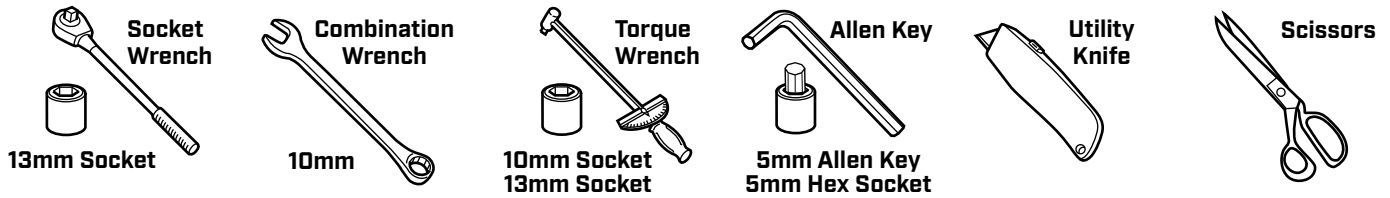

IMPORTANT

- ▼ USE ONLY THE TOOLS RECOMMENDED ABOVE.
- ▼ USE ONLY THE HARDWARE PROVIDED IN THIS KIT.
- ▼ ASSISTANCE WILL BE NEEDED FOR THIS INSTALLATION. FOUR PEOPLE ARE RECOMMENDED TO LIFT THE SMARTCAP ONTO THE VEHICLE.
- ▼ AVOID PINCHING OR CRUSHING HANDS AND FINGERS.
- ▼ INSPECT ALL KIT COMPONENTS FOR DAMAGE BEFORE ASSEMBLY.
- ▼ NEVER USE ACETONE OR THINNERS ON PAINTED PARTS.

COMPONENTS

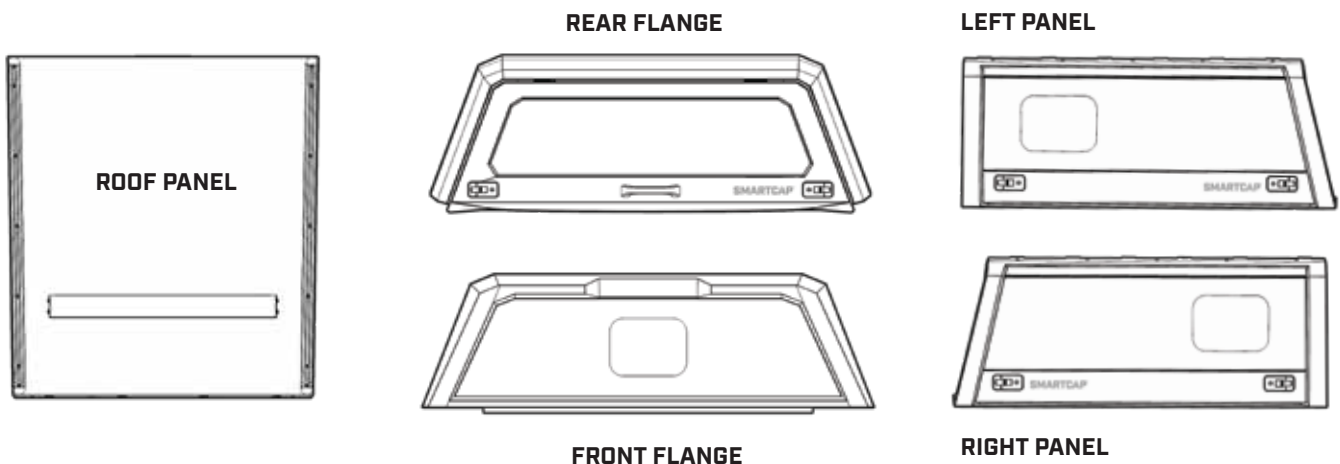

I-SHEET-SA-R2

ASSEMBLY HARDWARE

FITMENT KIT

M6 x 10mm BOLT

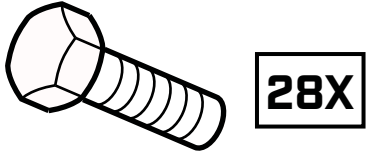

FASTENER
BLOCK CLAMP

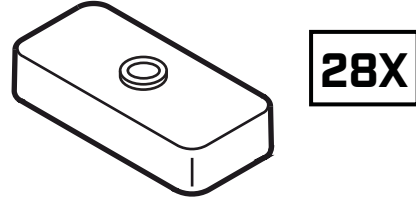

M6 LOCK
WASHER



FASTENER
BLOCK

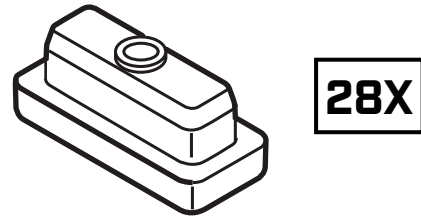

D - RUBBER



SPARE PARTS

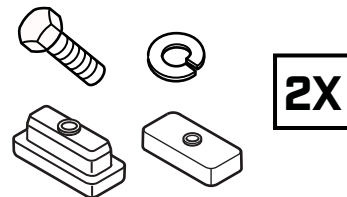

PRE-FASTENED TO ROOF PANEL

M6 FENDER
WASHER



M6 LOCK
NUT



STEP 1

2 PERSON JOB



IMPORTANT

- ▼ BE SURE TO REMOVE ALL FIVE PANELS FROM THEIR PACKAGING AND INSPECT THE PAINTED SURFACES PRIOR TO ASSEMBLY, AS SMARTCAP WILL NOT ACCEPT WARRANTY CLAIMS AFTER ASSEMBLY IS COMPLETED. IF MANUFACTURING IMPERFECTIONS OR SHIPPING DAMAGES ARE FOUND, DO NOT CONTINUE WITH THE ASSEMBLY PROCESS AND CONTACT SUPPORT.SA@SMARTCAP.COM - REST OF WORLD
SUPPORT.NA@SMARTCAP.COM - NORTH AMERICA/CANADA

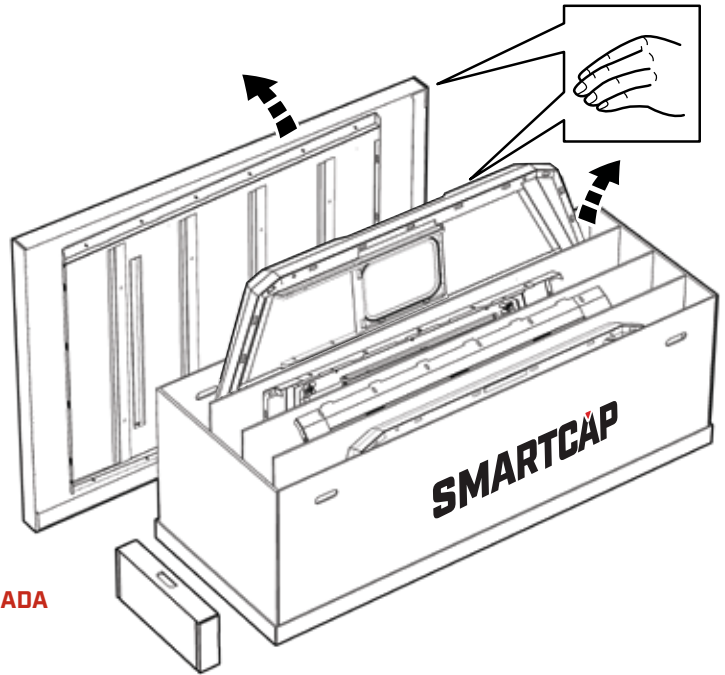

STEP 2

PLACE THE ROOF PANEL WHERE YOU PLAN TO ASSEMBLE THE CAP. REMOVE THE LID FROM THE PACKAGING AND PLACE IT NEXT TO THE ROOF PANEL.

LOGO SIDE UP

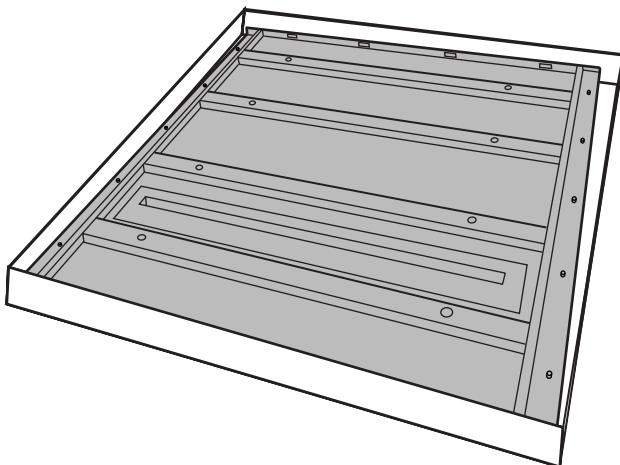
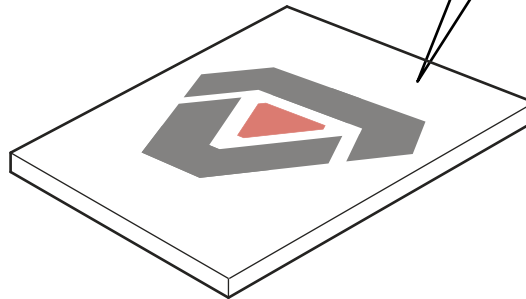

USE LID AS WORK SURFACE

I-SHEET-SA-R2

STEP 3

USE A 10MM COMBINATION WRENCH TO REMOVE ALL HARDWARE FROM THE ROOF PANEL AND SAVE FOR REUSE.



AIR VENT INDICATES REAR

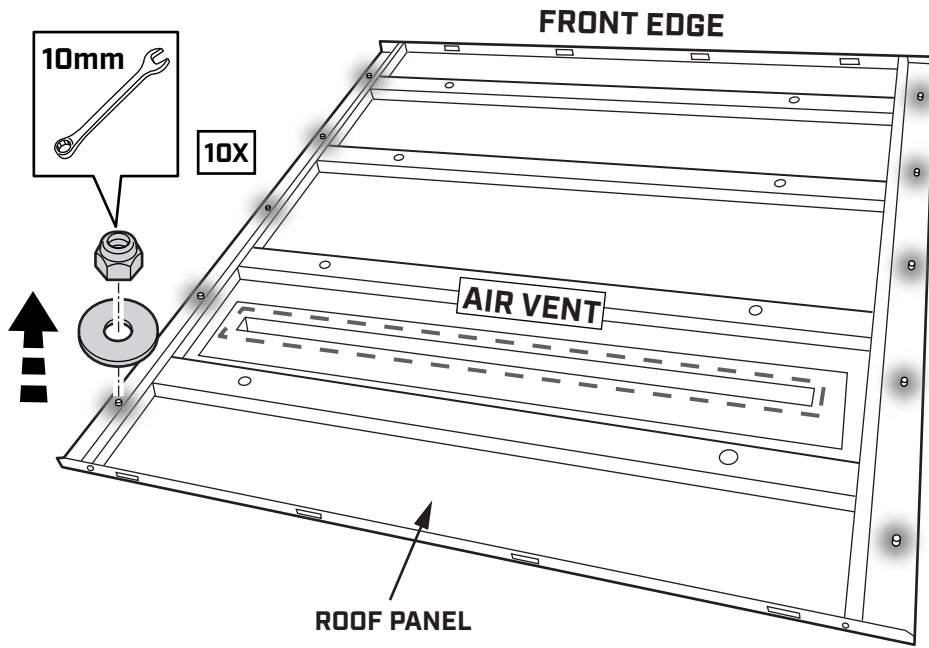

STEP 4

LOCATE THE RIGHT PANEL IN THE SMARTCAP PACKAGE AND BRING IT TO YOUR WORK AREA.



SLANTED EDGE INDICATES REAR

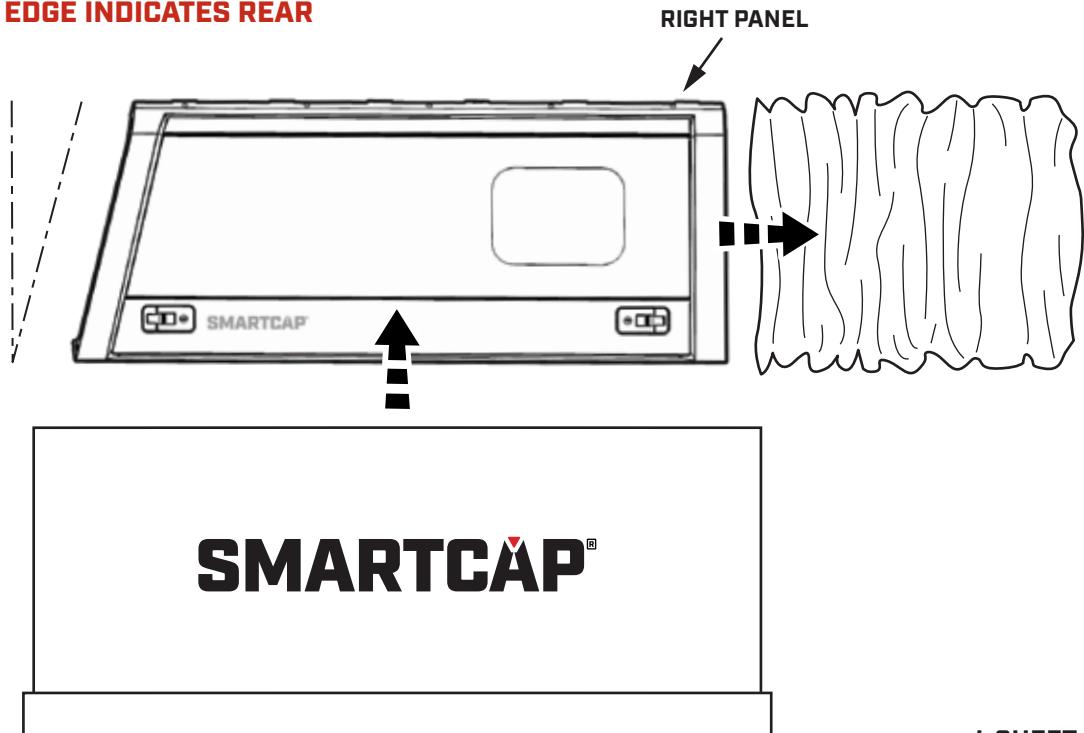

STEP 5

INSERT PANEL TABS INTO NARROW SLOTS JUST ABOVE FOAM PADDING ON ROOF PANEL.

TAP FIRMLY WITH PALM OF HAND UNTIL THERE IS A 2-3MM GAP.

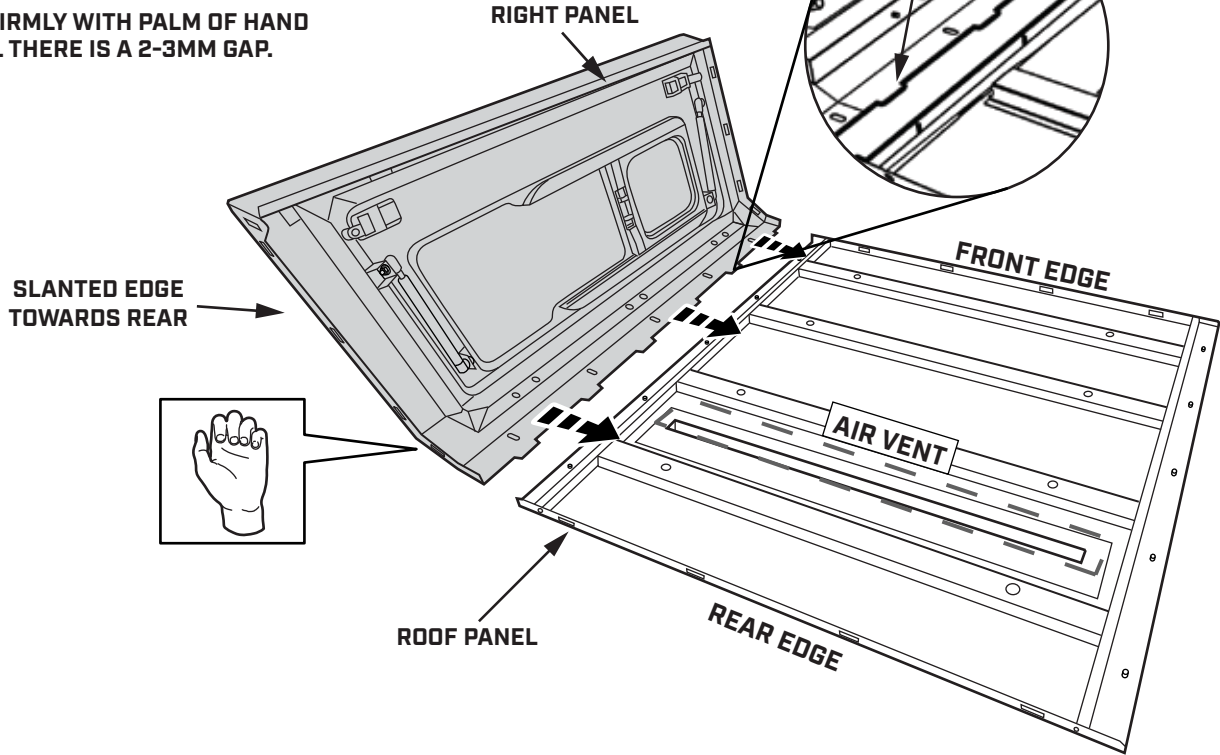

STEP 6

HAND TIGHTEN M6 LOCK NUT WITH M6 FENDER WASHER TO ALL ROOF STUDS.

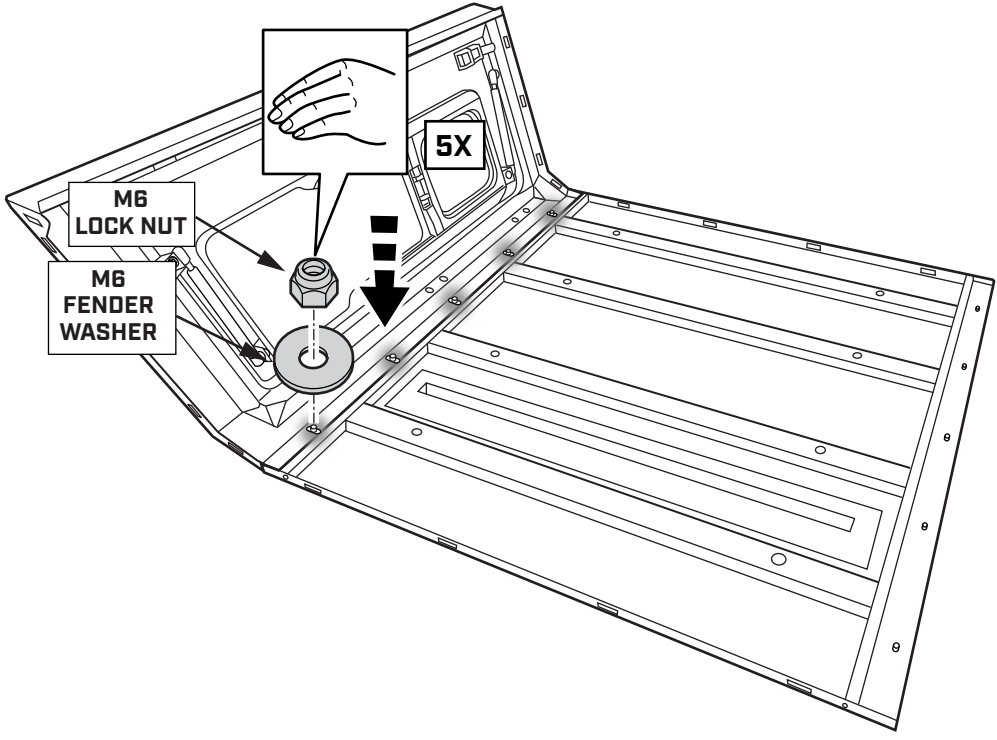

STEP 7

LOCATE THE LEFT PANEL IN THE SMARTCAP PACKAGE AND BRING IT TO YOUR WORK AREA.



SLANTED EDGE INDICATES REAR

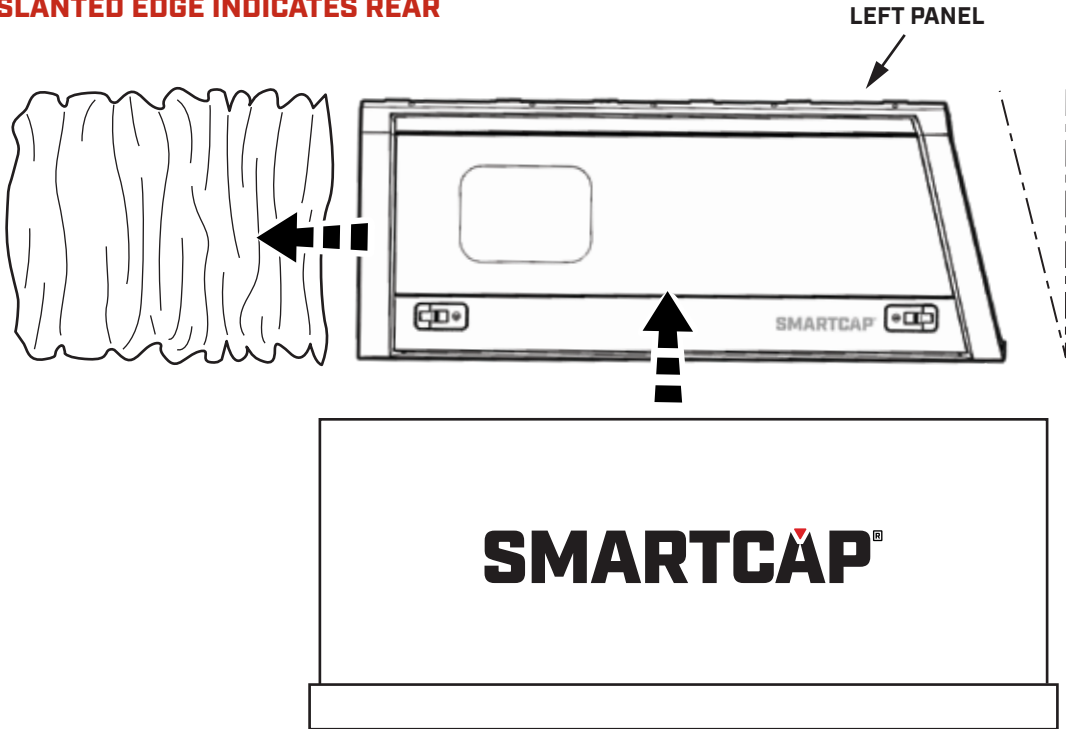

STEP 8

INSERT PANEL TABS INTO NARROW SLOTS JUST ABOVE FOAM PADDING ON ROOF PANEL.



TAP FIRMLY WITH PALM OF HAND UNTIL THERE IS A 2-3MM GAP.

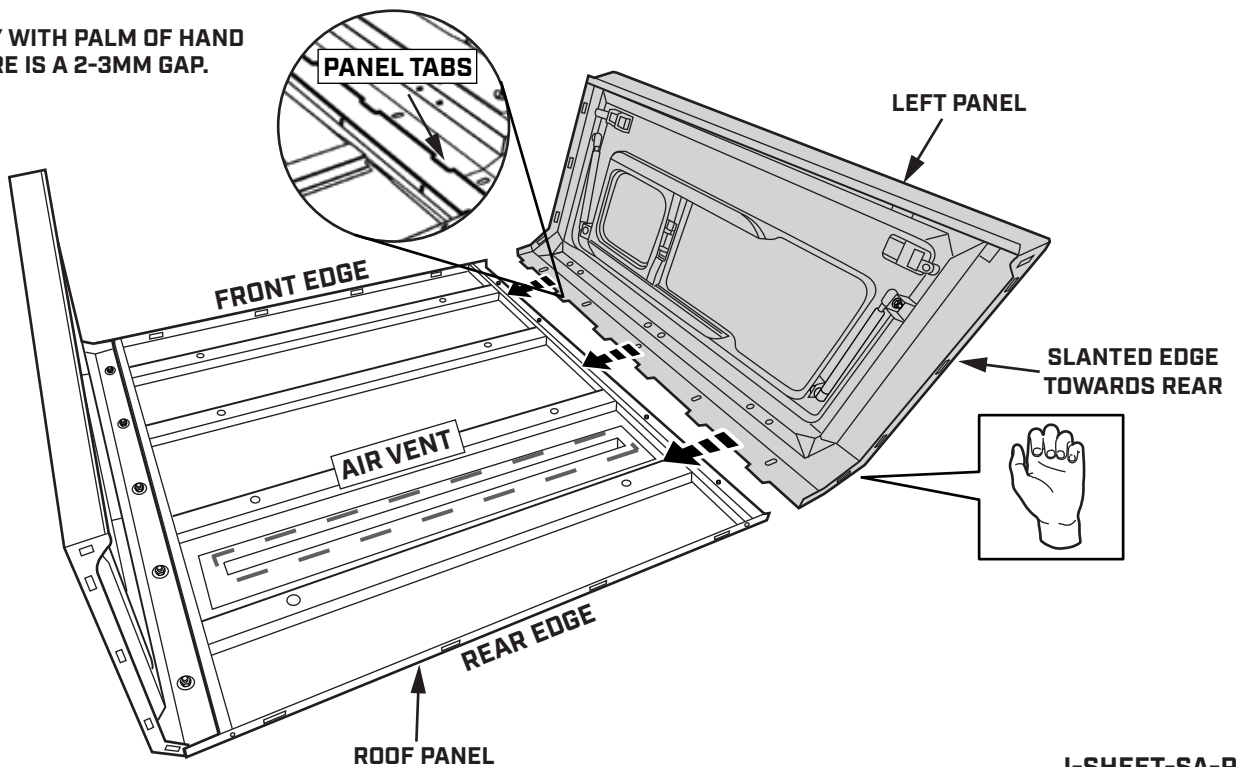

I-SHEET-SA-R2

STEP 9

HAND TIGHTEN M6 LOCK NUT WITH M6 FENDER WASHER TO ALL ROOF STUDS.

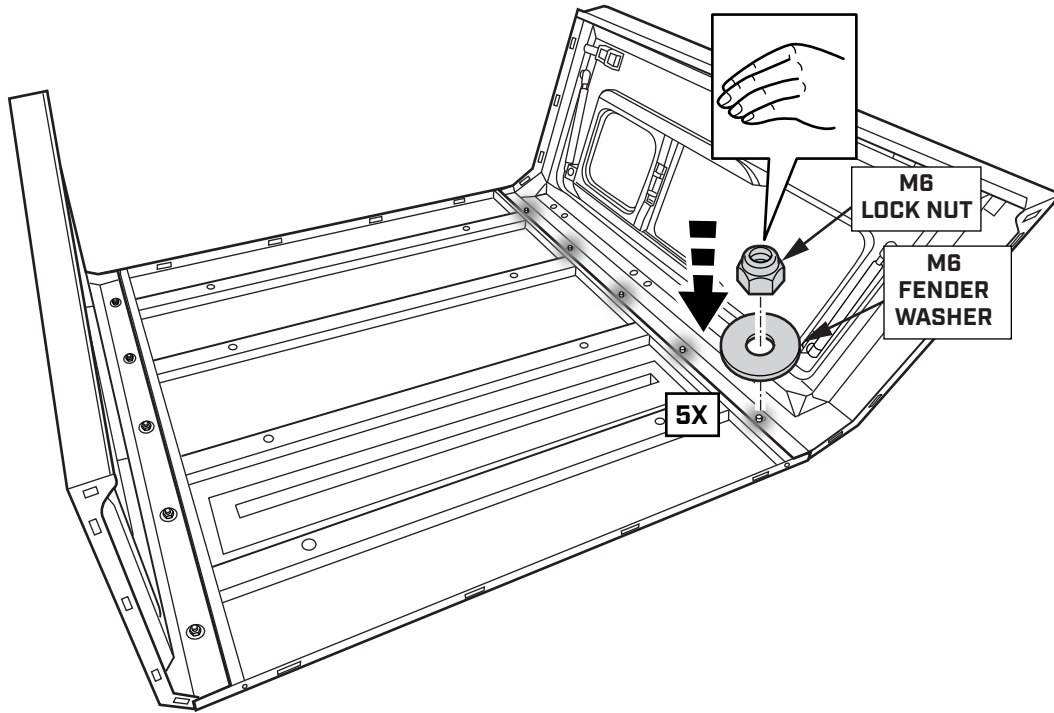

STEP 10

PUSH THE SMARTCAP TO EXPOSE A FEW INCHES OF STYRAFOAM UNDERNEATH THE ROOF PANEL TO PROVIDE SUPPORT FOR THE FRONT FLANGE.

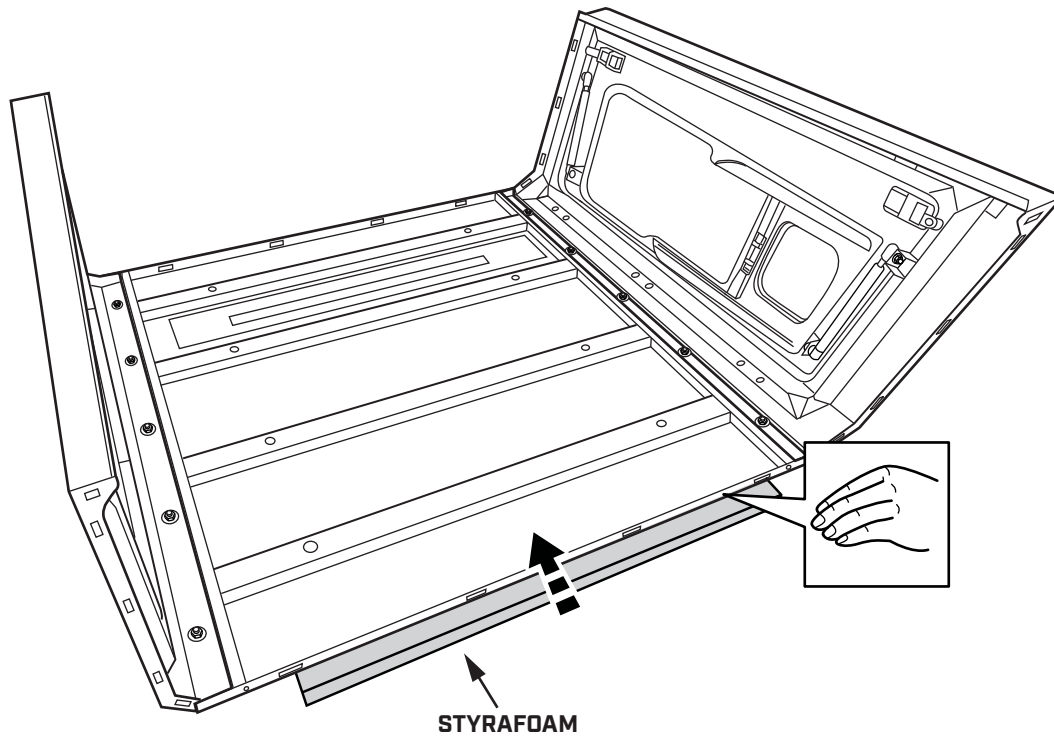

I-SHEET-SA-R2

STEP 11

RETRIEVE THE NECESSARY HARDWARE FROM THE FITMENT KIT.

LOCATE THE FRONT FLANGE IN THE SMARTCAP PACKAGE AND BRING IT TO YOUR WORK AREA.

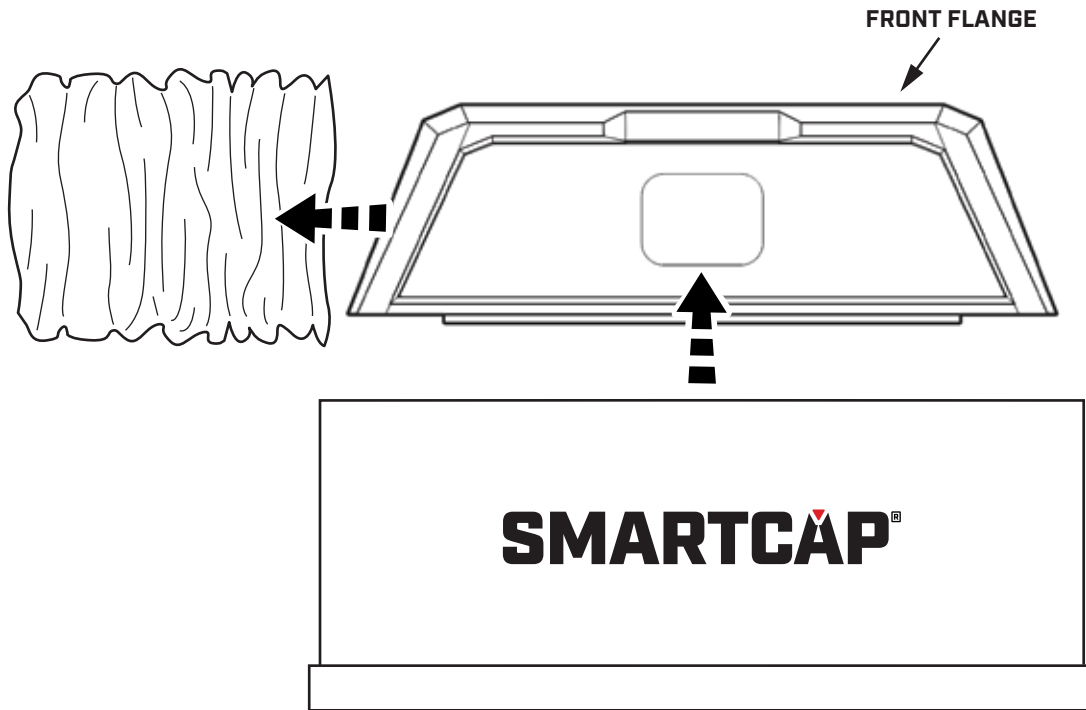

STEP 12

PLACE FRONT FLANGE AS SHOWN BELOW.

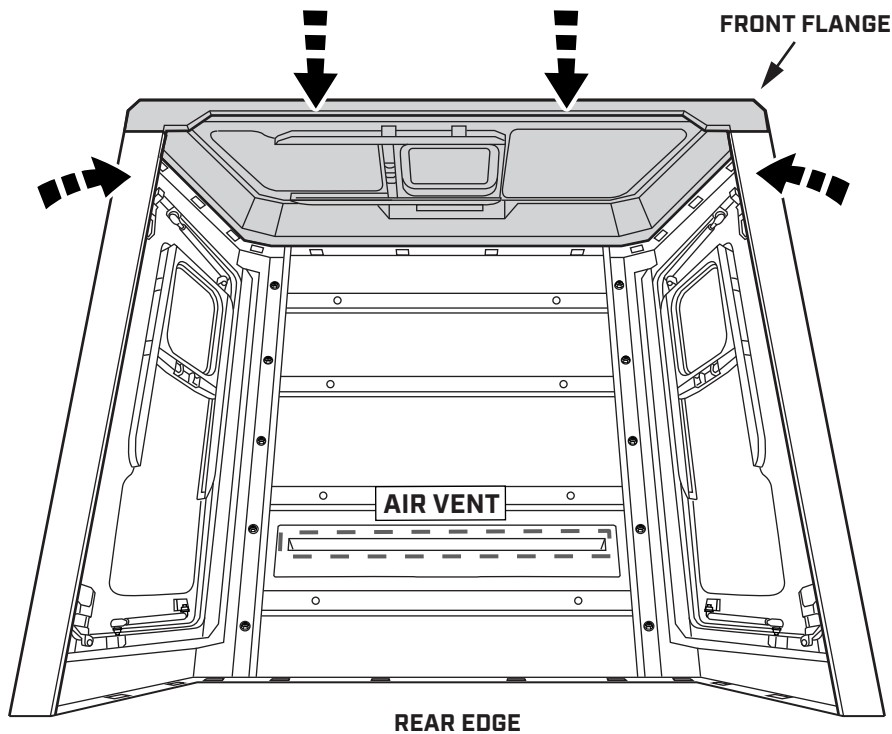

I-SHEET-SA-R2

STEP 13

INSTALL HARDWARE ALONG FRONT FLANGE WITH M6 BOLT ON INSIDE.

START WITH ASSEMBLING FASTENER BLOCKS 1-5.

ADJUST LEFT AND RIGHT PANELS TO ALIGN FASTENER BLOCKS 6-15 FOR ASSEMBLY.

HAND TIGHTEN IN THE SEQUENCE SHOWN.

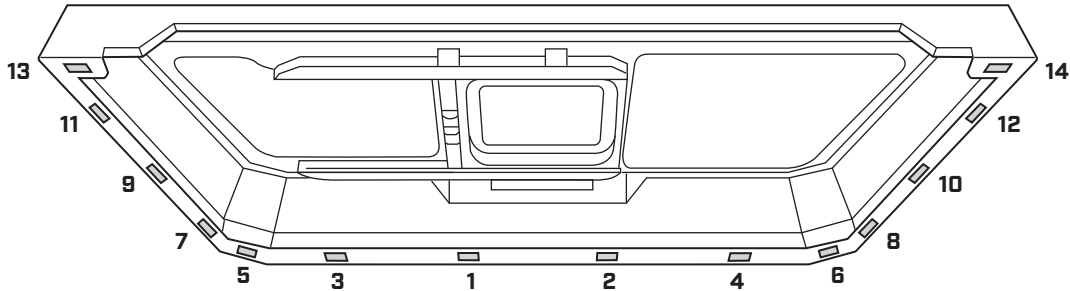
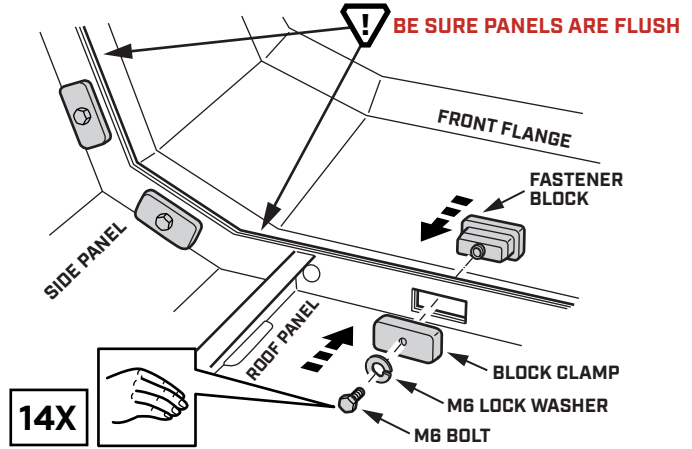

STEP 14

PUSH THE SMARTCAP TO EXPOSE A FEW INCHES OF STYRAFOAM UNDERNEATH THE ROOF PANEL TO PROVIDE SUPPORT FOR THE REAR FLANGE.

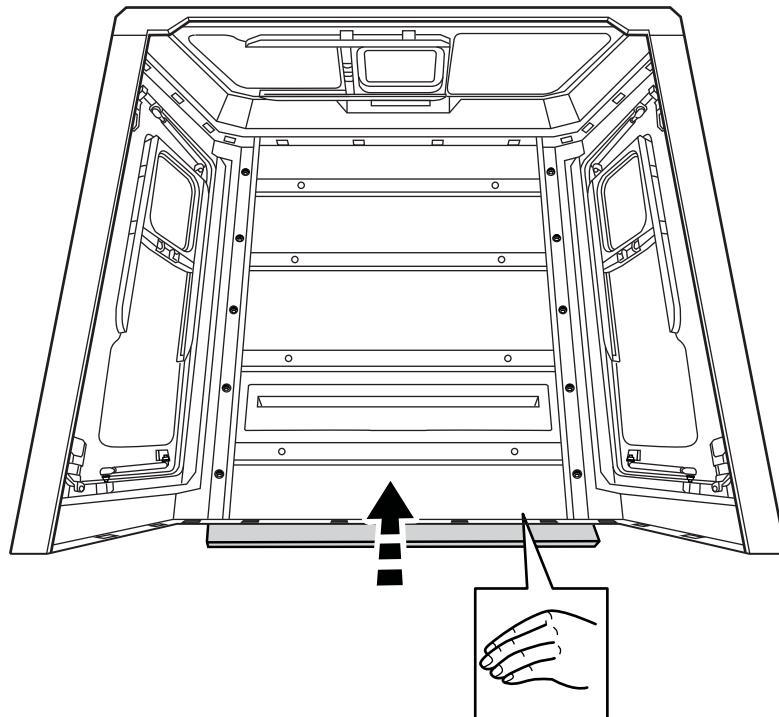

I-SHEET-SA-R2

STEP 15

RETRIEVE THE NECESSARY HARDWARE FROM THE FITMENT KIT.

LOCATE THE REAR FLANGE IN THE SMARTCAP PACKAGE AND BRING IT TO YOUR WORK AREA.

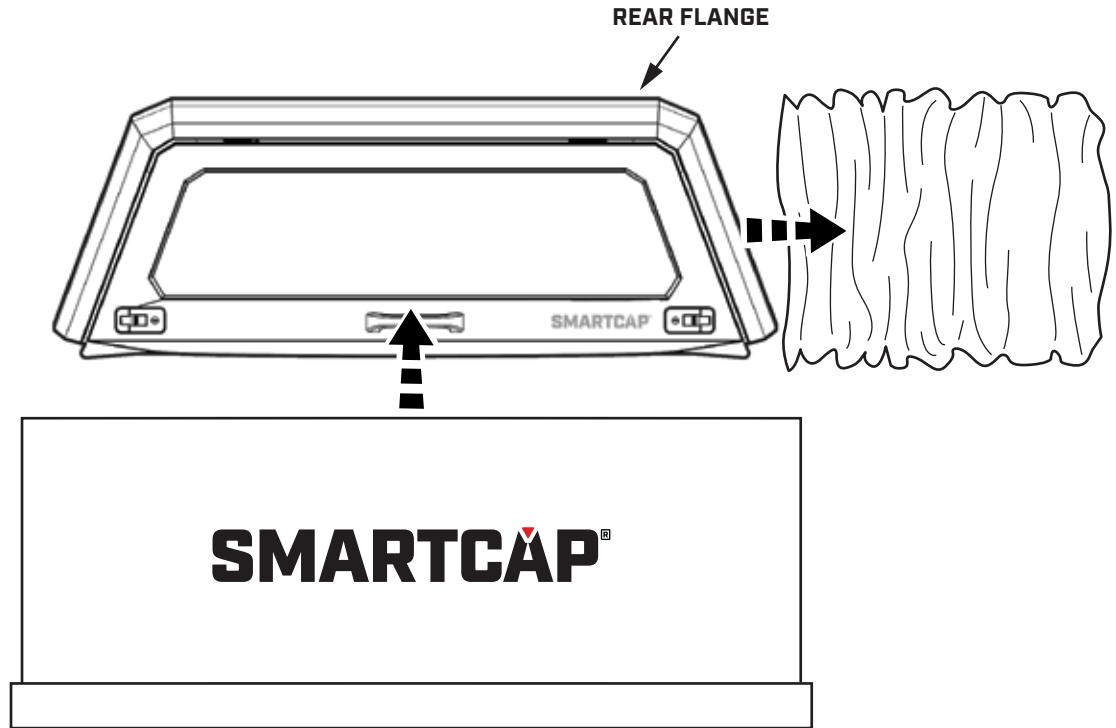
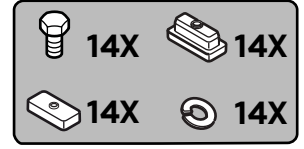

STEP 16

PLACE REAR FLANGE AS SHOWN BELOW.

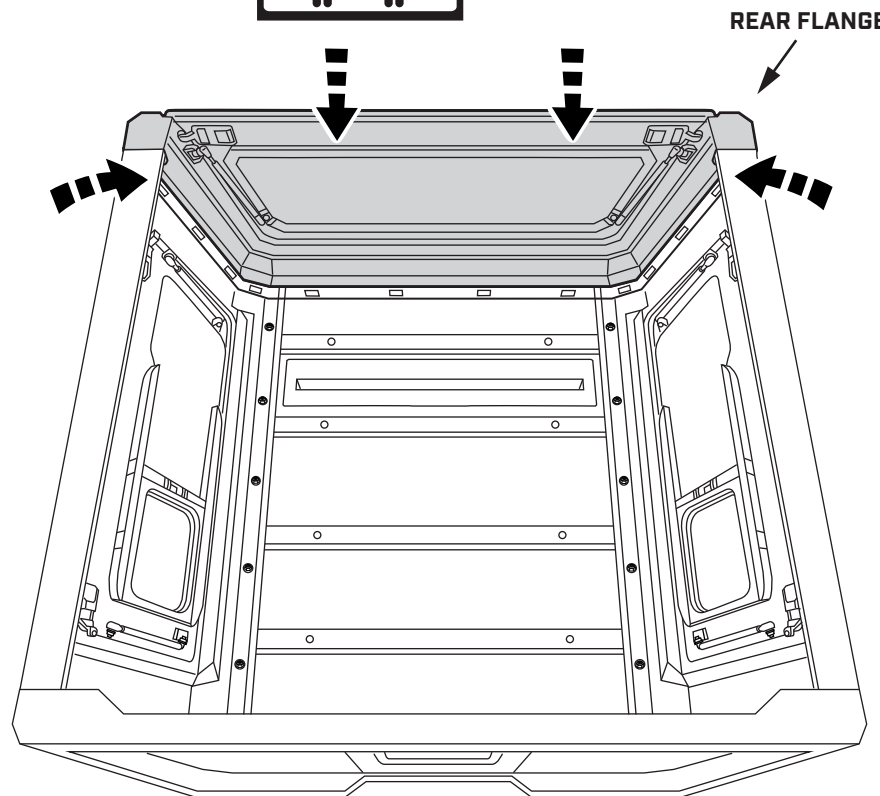

I-SHEET-SA-R2

STEP 17

INSTALL HARDWARE ALONG REAR FLANGE WITH BOLT ON INSIDE.

START WITH ASSEMBLING FASTENER BLOCKS 1-5.

ADJUST LEFT AND RIGHT PANELS TO ALIGN FASTENER BLOCKS 6-15 FOR ASSEMBLY.

HAND TIGHTEN IN THE SEQUENCE SHOWN.

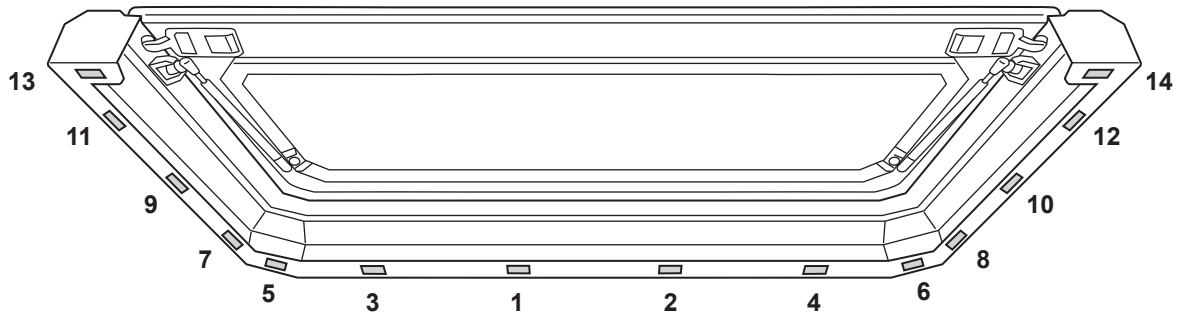
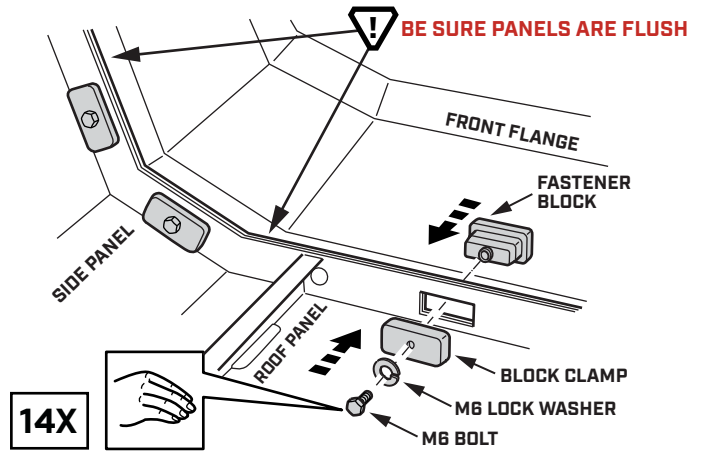

STEP 18

TIGHTEN ALL HARDWARE WITH TORQUE WRENCH AND 10MM SOCKET TO 3.7 FT. LBS. (5 NEWTON METERS)



[3.7 ft. lbs]/[5 Nm]

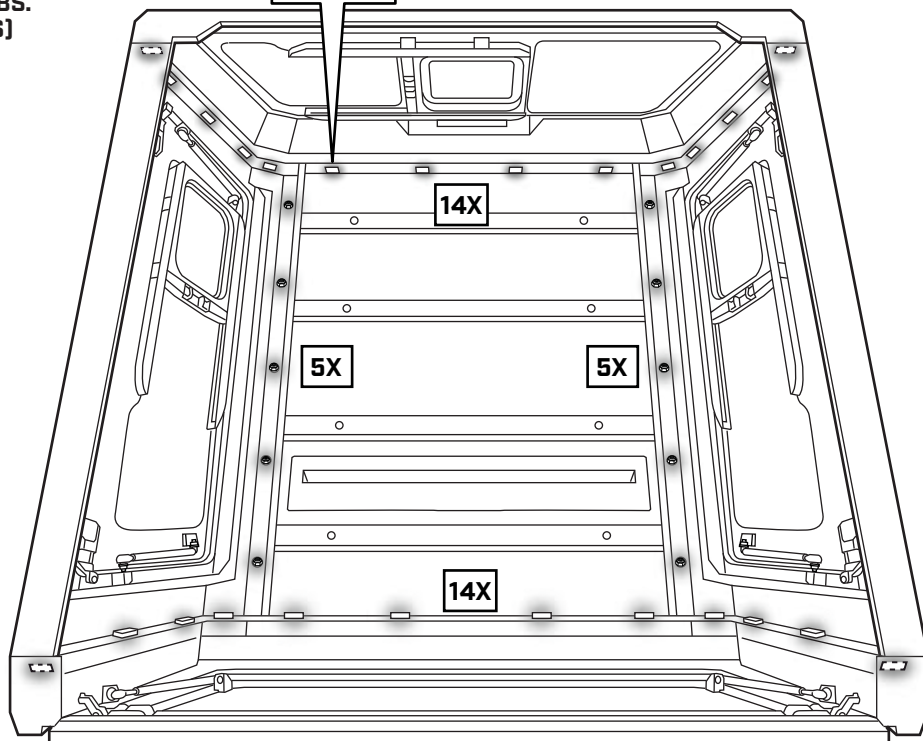

STEP 19

A LOCATE THE D-RUBBER RETENTION TAB NEXT TO THE REAR DOOR GASKET.

BEND THE TAB UPWARDS AT A 45 DEGREE ANGLE.

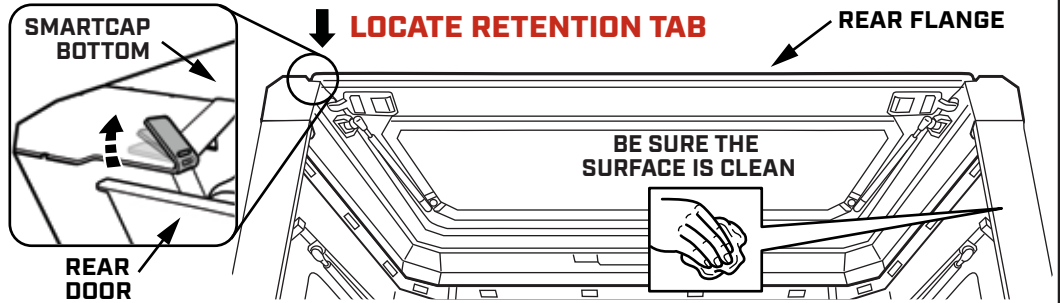

B PEEL AWAY A SMALL PORTION OF THE ADHESIVE BACKING FROM THE D-RUBBER.

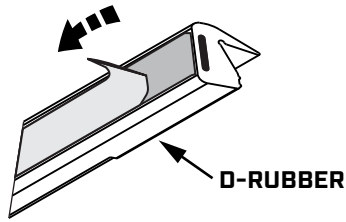

C INSERT THE TAB INTO THE D-RUBBER UNTIL THE D-RUBBER LIGHTLY BUTTS UP AGAINST REAR DOOR GASKET.

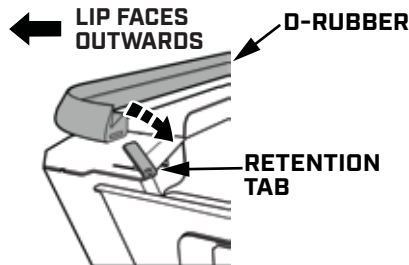

D FIRMLY PUSH THE TAB BACK DOWN TO SECURE THE D-RUBBER IN PLACE.

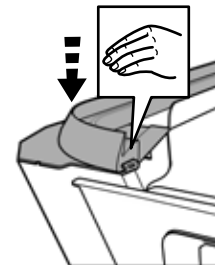

CORRECT D-RUBBER ORIENTATION

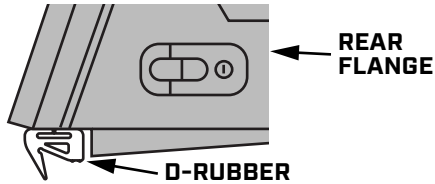

INCORRECT D-RUBBER ORIENTATION

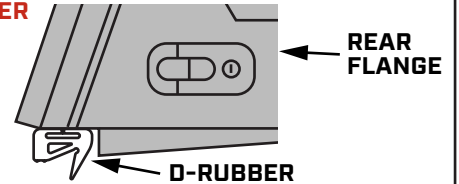

STEP 20

PEEL AWAY ADHESIVE BACKING IN SHORT LENGTHS AS YOU WORK AROUND THE EDGES.

STAY WITHIN 1/8 INCH FROM THE SMARTCAP'S OUTER EDGES.

REMOVE EXCESS WITH A STRAIGHT CUT.

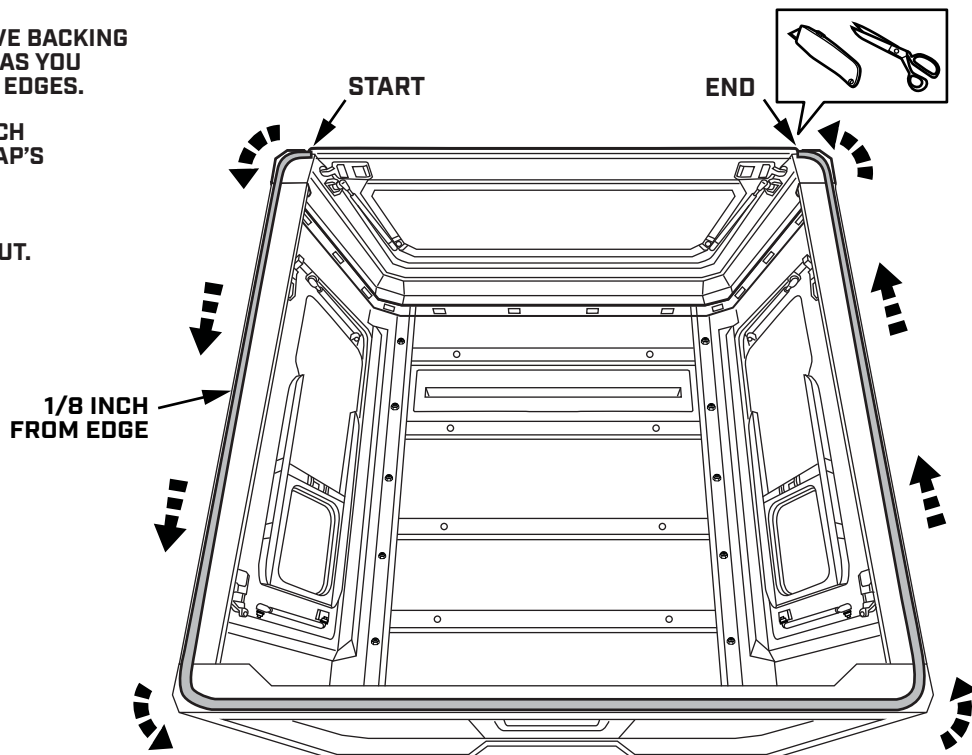

INSTALLATION HARDWARE

MOUNTING BRACKETS

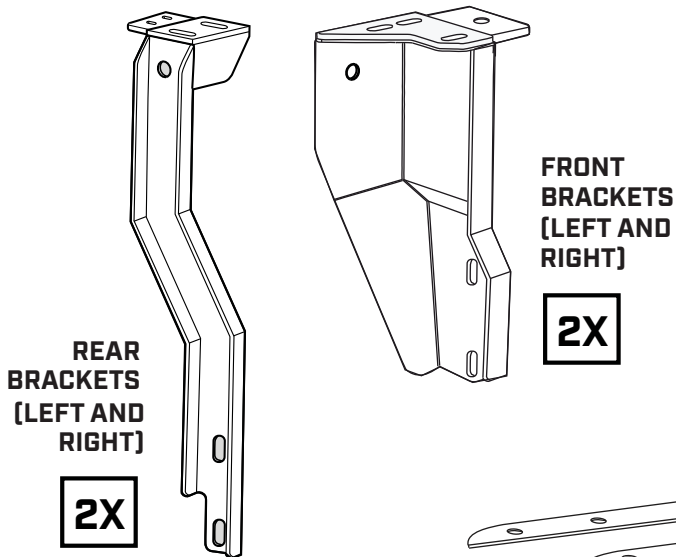

25mm x 25mm FOAM SEAL TAPE

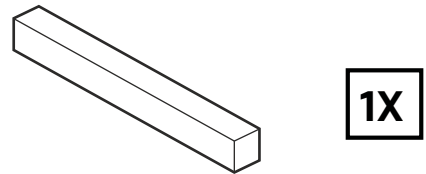
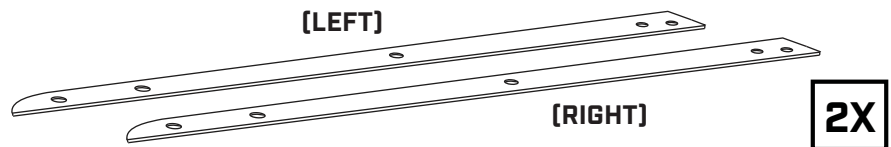

PLATE STRIPS



M8 x 20mm BOLT



M8 LOCK WASHER



M8 FENDER WASHER



M8 x 20mm BUTTON BOLT



M8 LOCK NUT



LOAD SPREADER

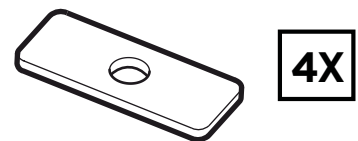

VEHICLE INSTALLATION

IMPORTANT

- ▼ ASSISTANCE WILL BE NEEDED FOR THIS INSTALLATION. FOUR PEOPLE ARE RECOMMENDED TO LIFT THE SMARTCAP ONTO THE VEHICLE.
- ▼ AVOID PINCHING OR CRUSHING HANDS AND FINGERS.
- ▼ READ THROUGH THE ENTIRE PROCEDURE BEFORE STARTING.

STEP 21

REMOVE THE PLASTIC BED-RAIL CAP INSERTS AND BED-RAIL CAPS.

REPEAT ON THE OPPOSITE SIDE OF THE VEHICLE.

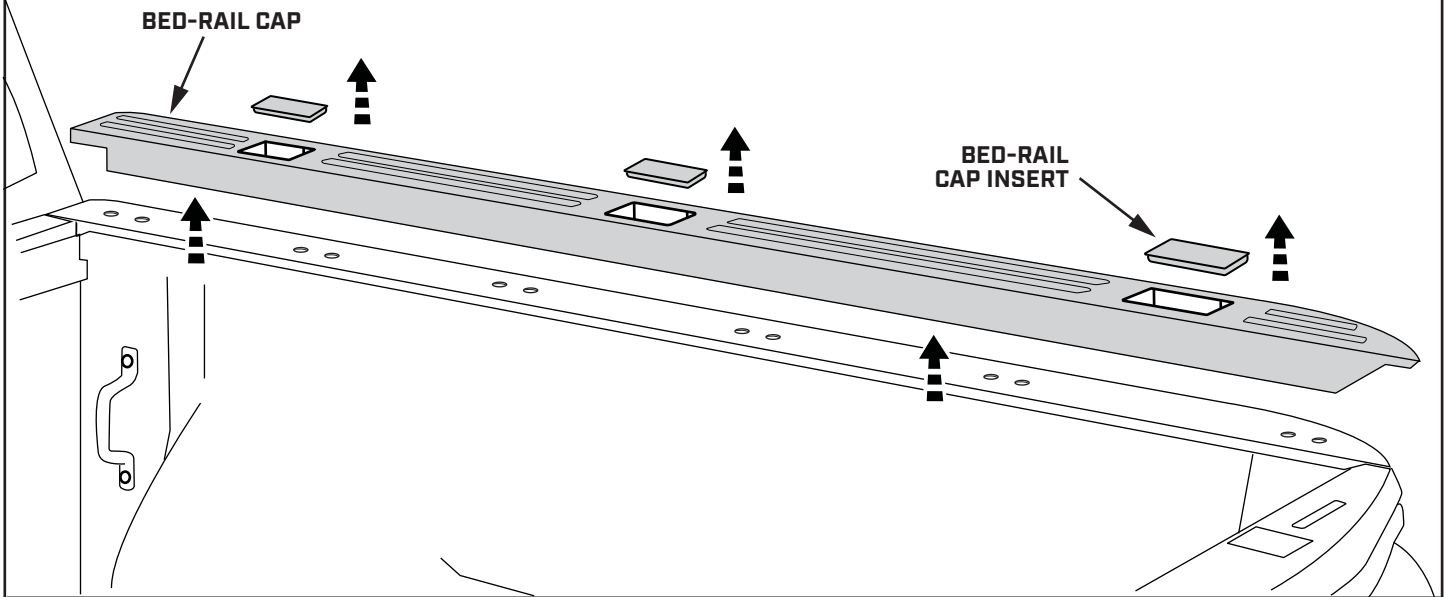

STEP 22

REMOVE THE ADHESIVE BACKING FROM THE PLATE STRIP AND APPLY TO THE BIN RAIL, ALIGNING THE FRONT OF THE PLATE STRIP TO THE FRONT OF THE BIN.

REPEAT ON THE OPPOSITE SIDE OF THE VEHICLE.

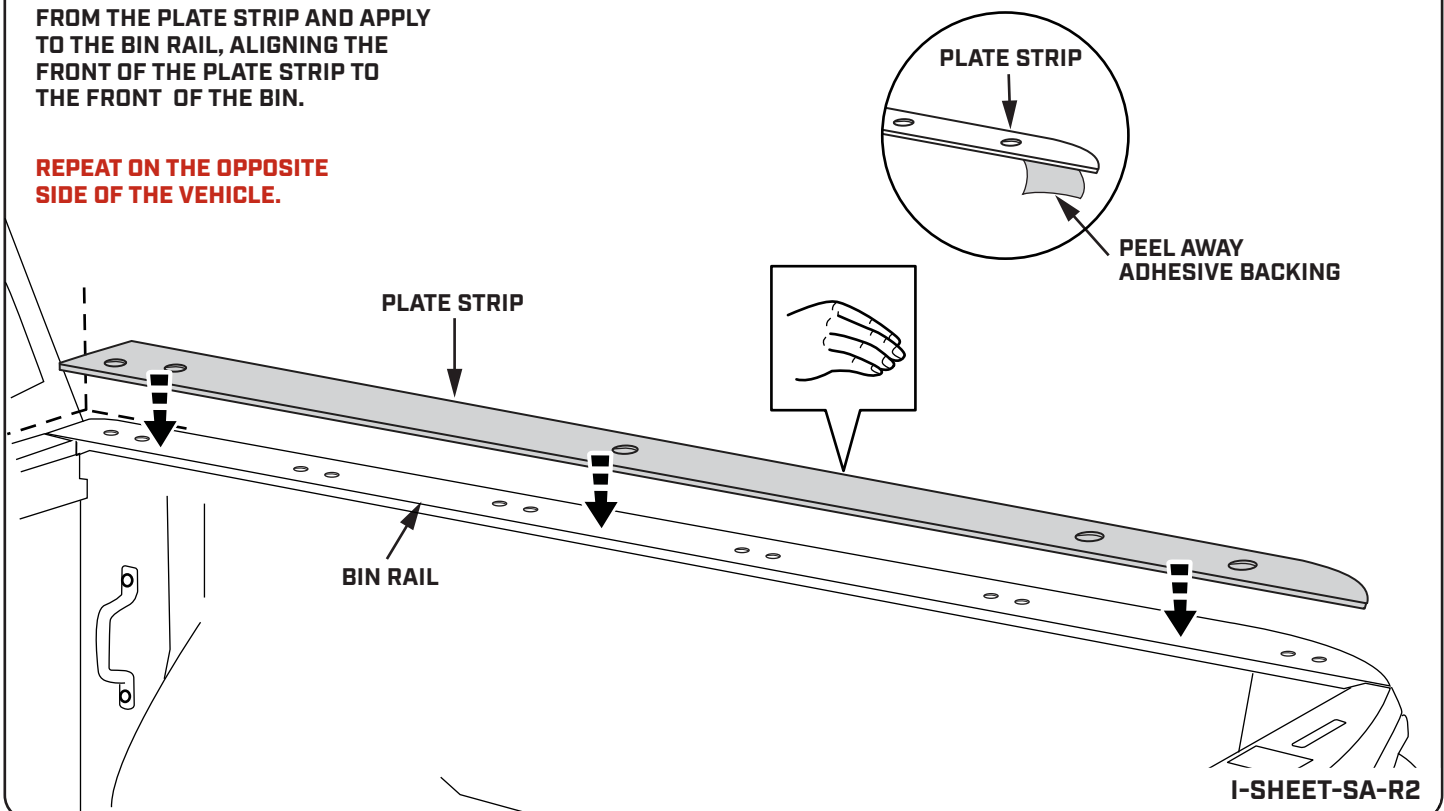

I-SHEET-SA-R2

STEP 23

INSPECT THE TRUCK BED. IF FRONT EDGE IS LOWER THAN THE SIDES, ADD FOAM SEAL TAPE TO THE FRONT EDGE OF THE BED.

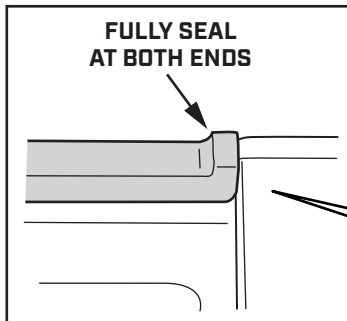
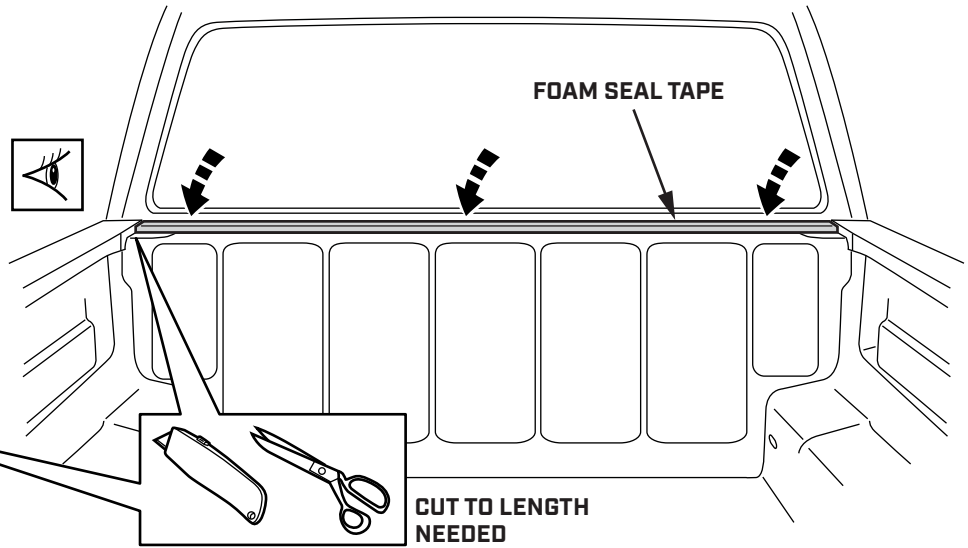
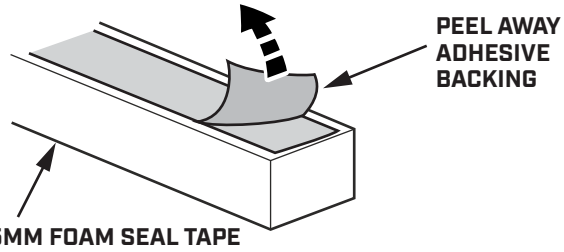
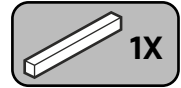

STEP 24

REMOVE THE FRONT TIE DOWN HOOK FROM THE INNER WALL OF THE TRUCK BED.

POSITION THE RIGHT SIDE FRONT MOUNTING BRACKET IN THE FRONT CORNER OF THE TRUCK BED AS SHOWN.

SECURE THE BRACKET WITH THE FASTENERS AS INDICATED, HAND TIGHTEN ONLY.

REPEAT ON THE OPPOSITE SIDE OF THE VEHICLE WITH THE LEFT FRONT MOUNTING BRACKET.

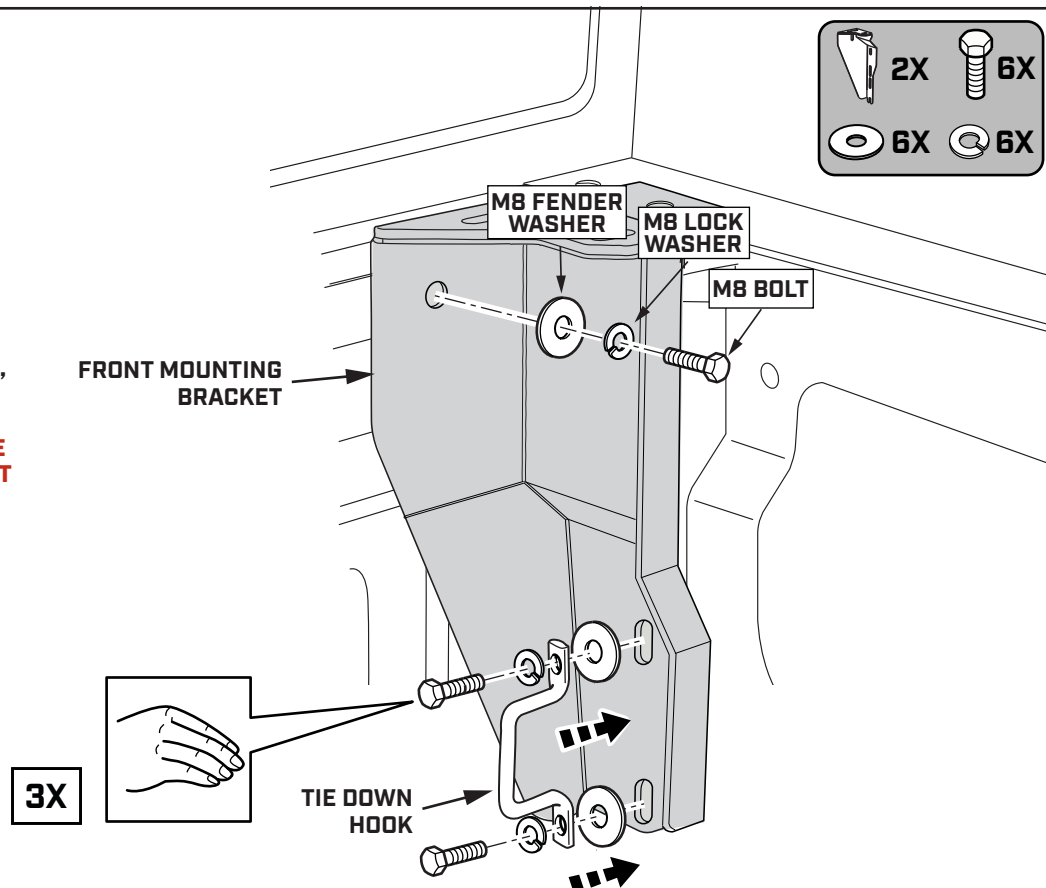
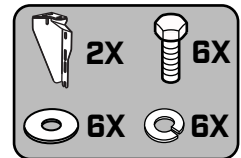

STEP 25

USE A 5MM ALLEN KEY TO FASTEN THE FRONT RIGHT MOUNTING BRACKET TO THE TOP OF THE TRUCK BED.

SECURE THE BRACKET WITH THE FASTENERS AS INDICATED.

REPEAT ON THE OPPOSITE SIDE OF THE VEHICLE WITH THE LEFT FRONT MOUNTING BRACKET.

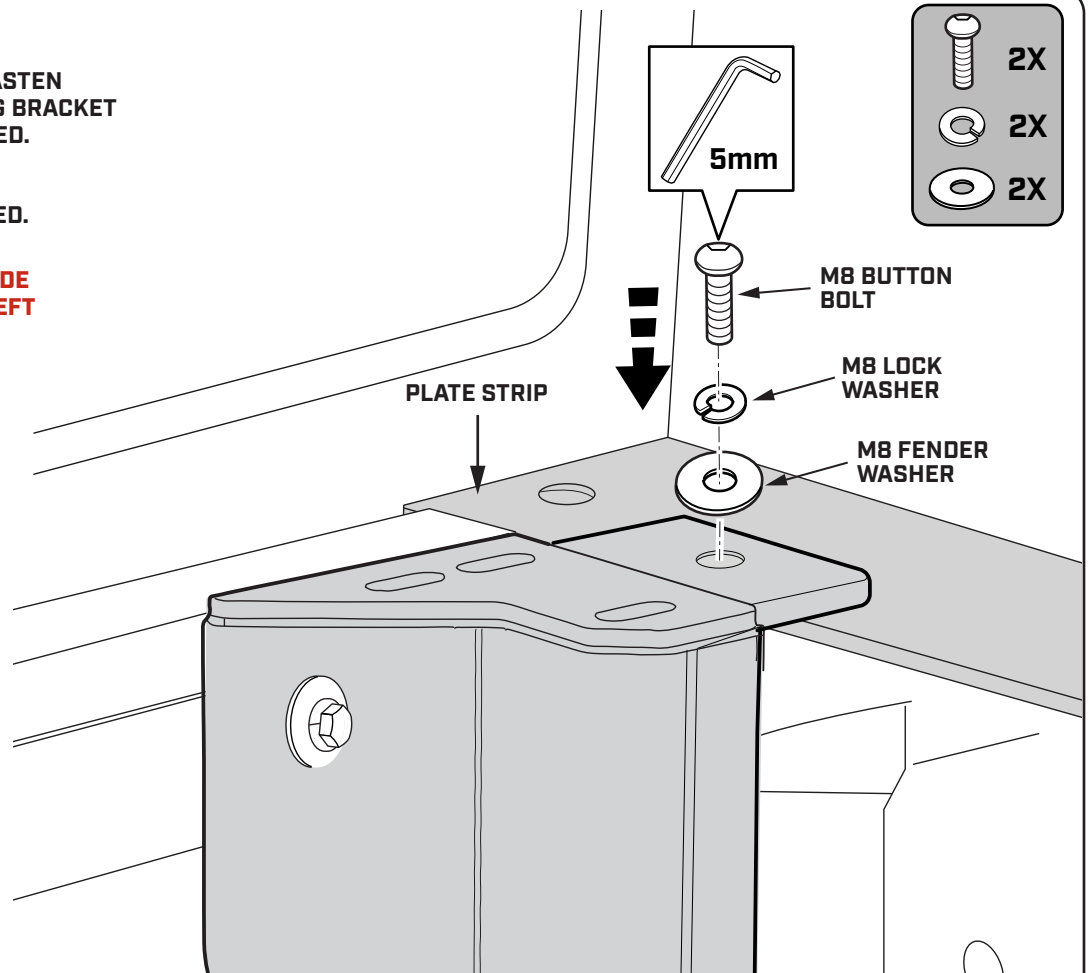

STEP 26

REMOVE THE REAR TIE DOWN HOOK FROM THE INNER WALL OF THE TRUCK BED.

POSITION THE RIGHT SIDE REAR MOUNTING BRACKET IN THE BACK CORNER OF THE TRUCK BED AS SHOWN.

SECURE THE BRACKET WITH THE FASTENERS AS INDICATED, HAND TIGHTEN ONLY.

REPEAT ON THE OPPOSITE SIDE OF THE VEHICLE WITH THE LEFT REAR MOUNTING BRACKET.

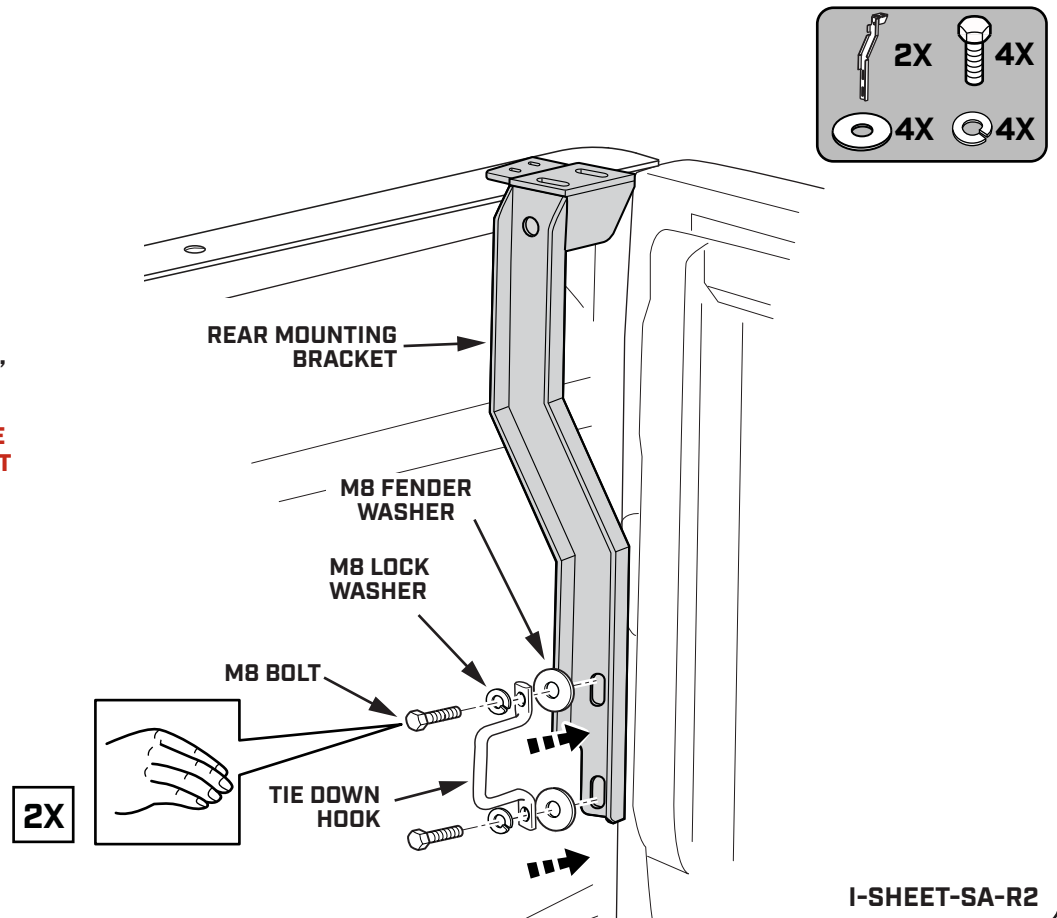

I-SHEET-SA-R2

STEP 27

USE A 5MM ALLEN KEY TO FASTEN THE REAR RIGHT MOUNTING BRACKET TO THE TOP OF THE TRUCK BED.

SECURE THE BRACKET WITH THE FASTENERS AS INDICATED.

REPEAT ON THE OPPOSITE SIDE OF THE VEHICLE WITH THE LEFT FRONT MOUNTING BRACKET.

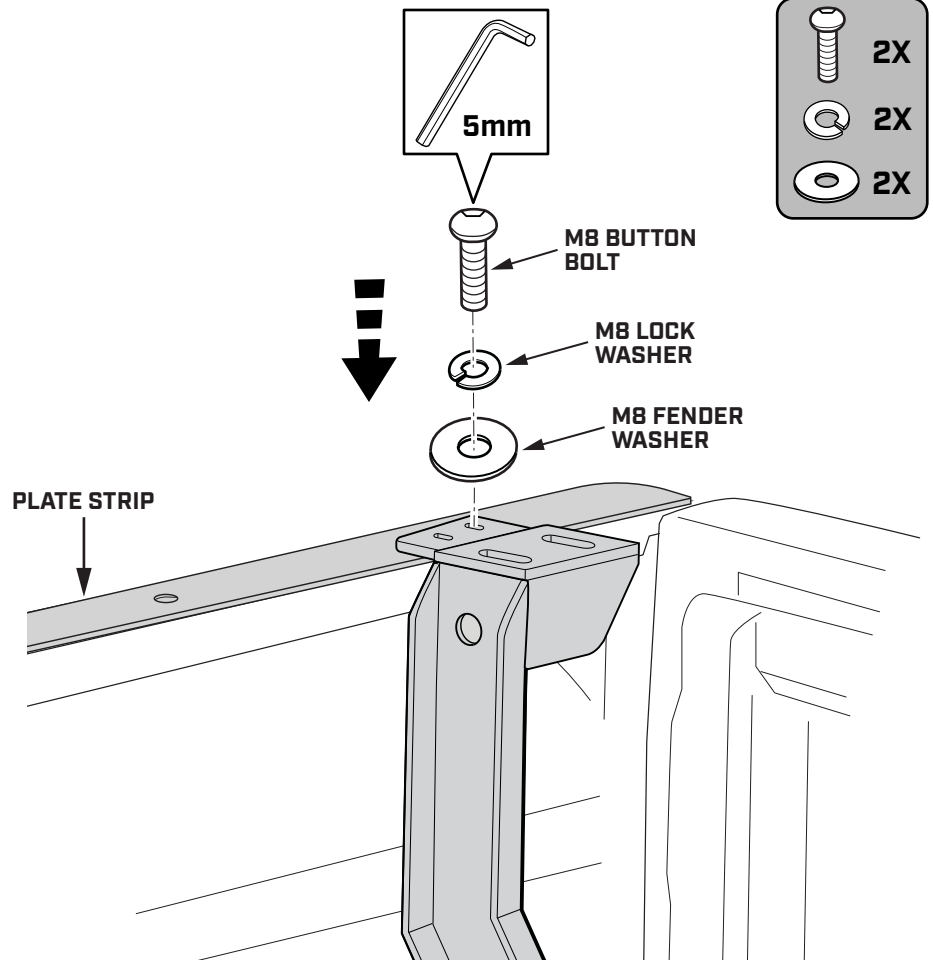

STEP 28

REMOVE THE ADHESIVE BACKING FROM LOAD SPREADER

APPLY LOAD SPREADERS TO THE TOP OF PLATE STRIP. USE THE SLOTS TO ALIGN

REPEAT ON THE OPPOSITE SIDE OF THE VEHICLE.

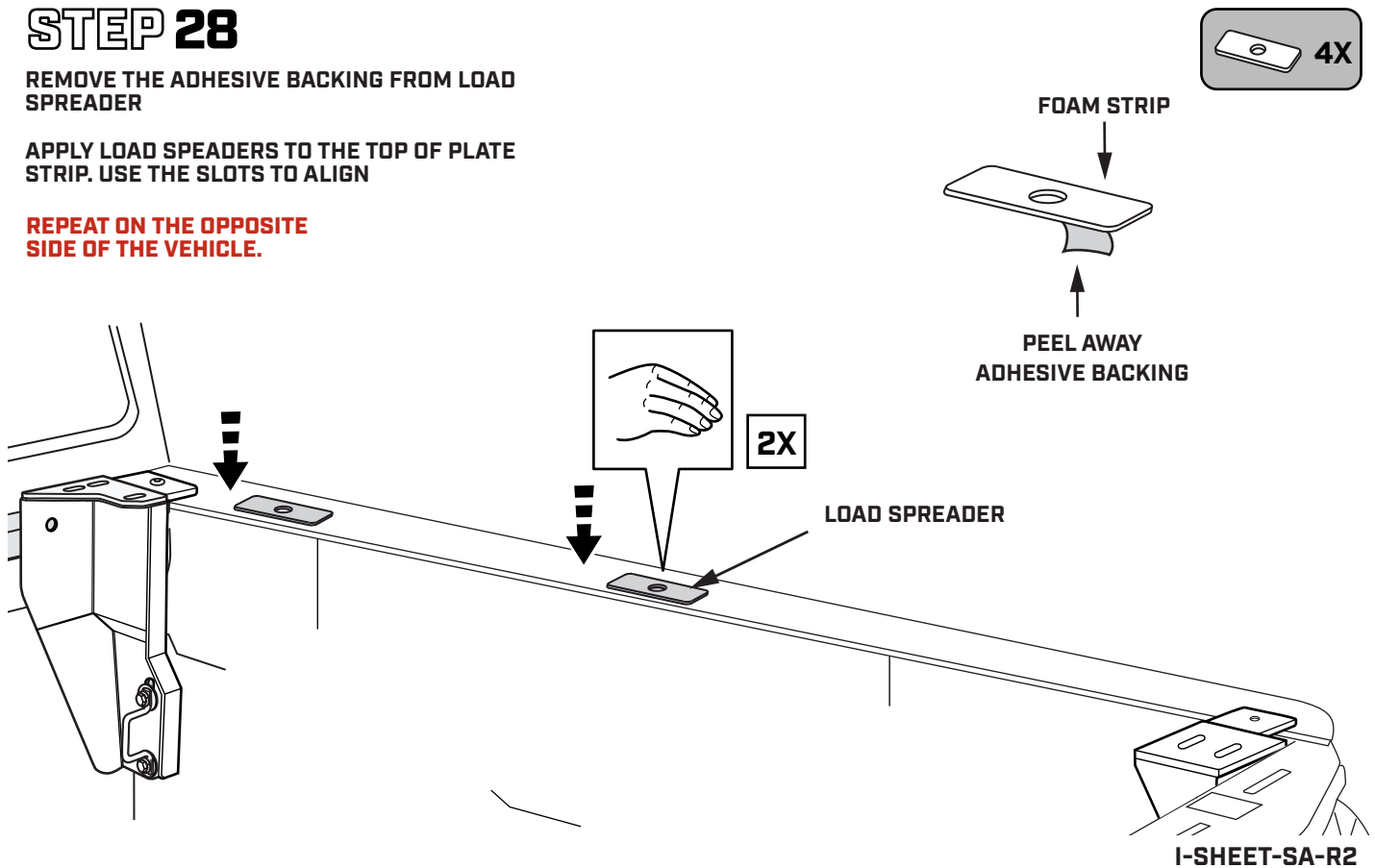

STEP 29

USE 4 PEOPLE TO LIFT THE ASSEMBLED SMARTCAP ONTO THE TRUCK BED.

TO AVOID DAMAGE TO THE D-RUBBER, DO NOT SLIDE THE SMARTCAP INTO PLACE.

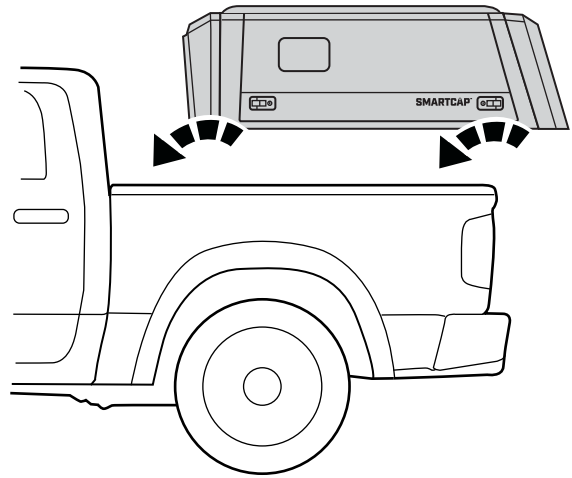

STEP 30

CHECK THAT THE SMARTCAP IS PROPERLY POSITIONED AND CENTERED ON THE TRUCK BED.

IT'S IMPORTANT THAT THE SMARTCAP IS NOT PUSHED TOO FAR FORWARD, LEAVING A GAP BETWEEN THE SMARTCAP AND THE CAB.

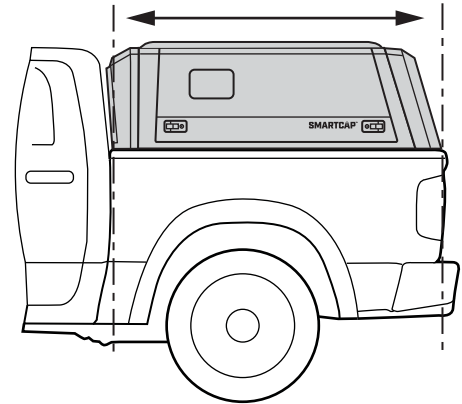
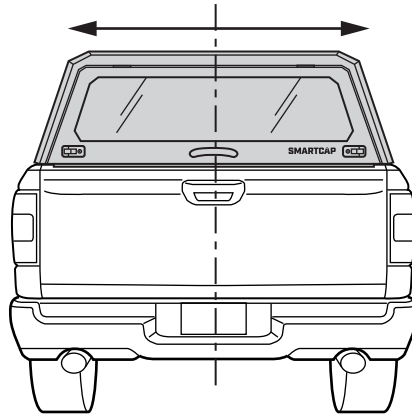

STEP 31

WALK AROUND THE TRUCK BED TO MAKE SURE THE D-RUBBER FITMENT IS CORRECT AND THAT THE RUBBER LIP IS FLUSH WITH THE EXTERIOR OF THE TRUCK BED.

CORRECT D-RUBBER ORIENTATION

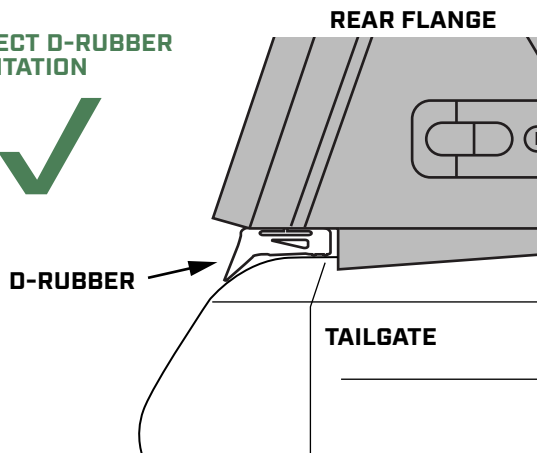

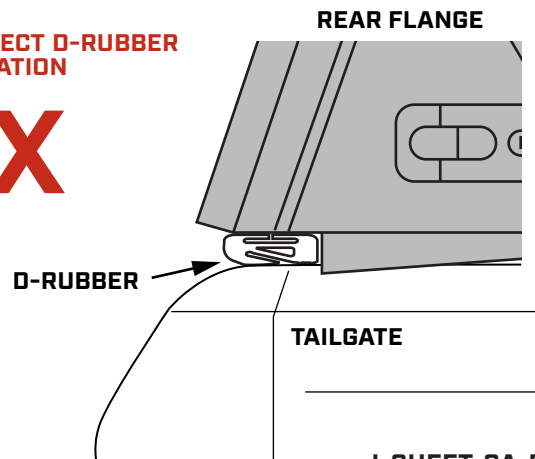

INCORRECT D-RUBBER ORIENTATION



I-SHEET-SA-R2

STEP 32

WITH A 5MM ALLEN KEY, LOOSELY TIGHTEN THE SMARTCAP RIGHT SIDE PANEL TO THE TOP OF THE TRUCK BED USING M8 BUTTON HEAD BOLT, M8 LOCK WASHER, AND M8 FENDER WASHER AS SHOWN BELOW.

-  4X
-  4X
-  4X

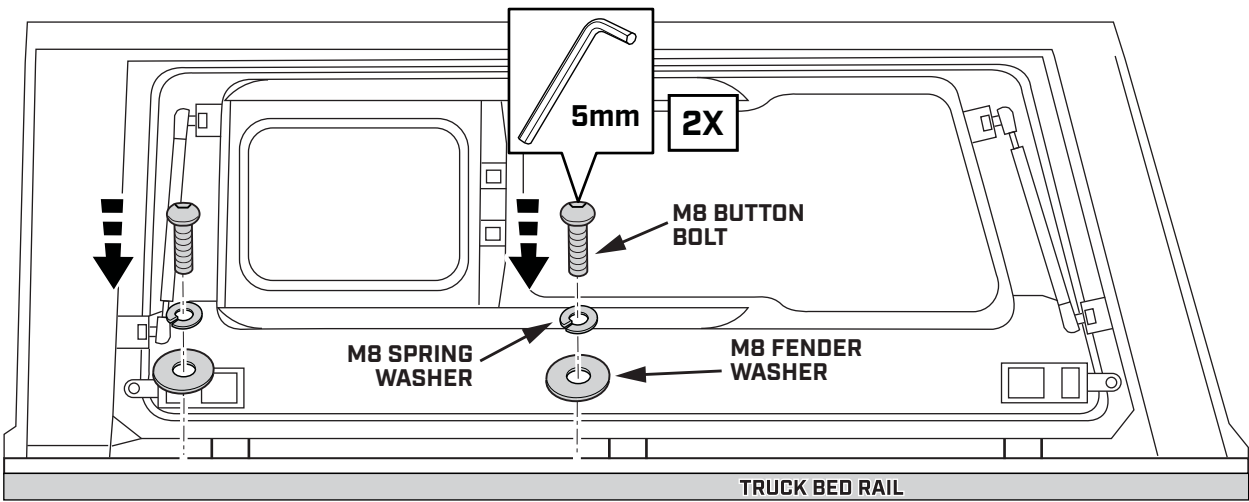

REPEAT ON THE OPPOSITE SIDE OF THE VEHICLE.



STEP 33

SECURE THE SMARTCAP TO THE RIGHT FRONT MOUNTING BRACKET WITH THE FASTENERS AS INDICATED, HAND TIGHTEN ONLY.

REPEAT ON THE OPPOSITE SIDE OF THE VEHICLE WITH THE LEFT FRONT MOUNTING BRACKET.

-  6X
-  12X
-  6X

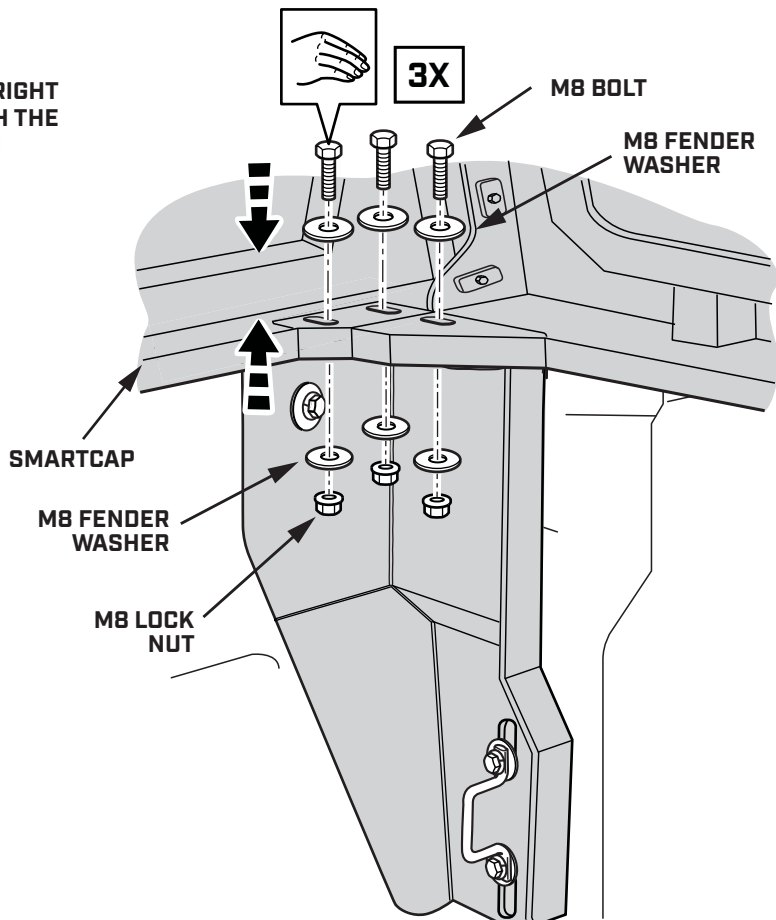

STEP 34

SECURE THE SMARTCAP TO THE RIGHT REAR MOUNTING BRACKET WITH THE FASTENERS AS INDICATED, HAND TIGHTEN ONLY.

REPEAT ON THE OPPOSITE SIDE OF THE VEHICLE WITH THE LEFT REAR MOUNTING BRACKET.

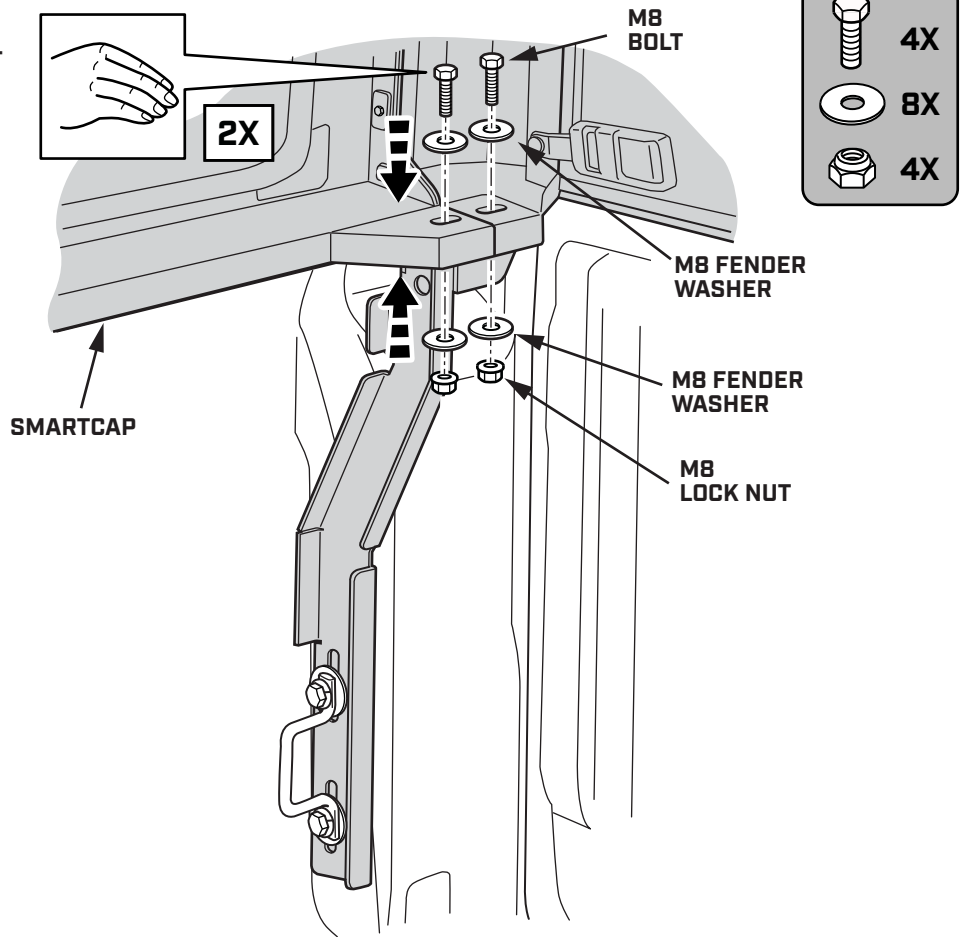

STEP 35

ONCE ALL THE FASTENERS ARE INSTALLED, PARTIALLY TIGHTEN WITH 13MM SOCKET WRENCH AS INDICATED.

PARTIALLY TIGHTEN FASTENERS ON ALL FOUR CORNERS OF THE VEHICLE.

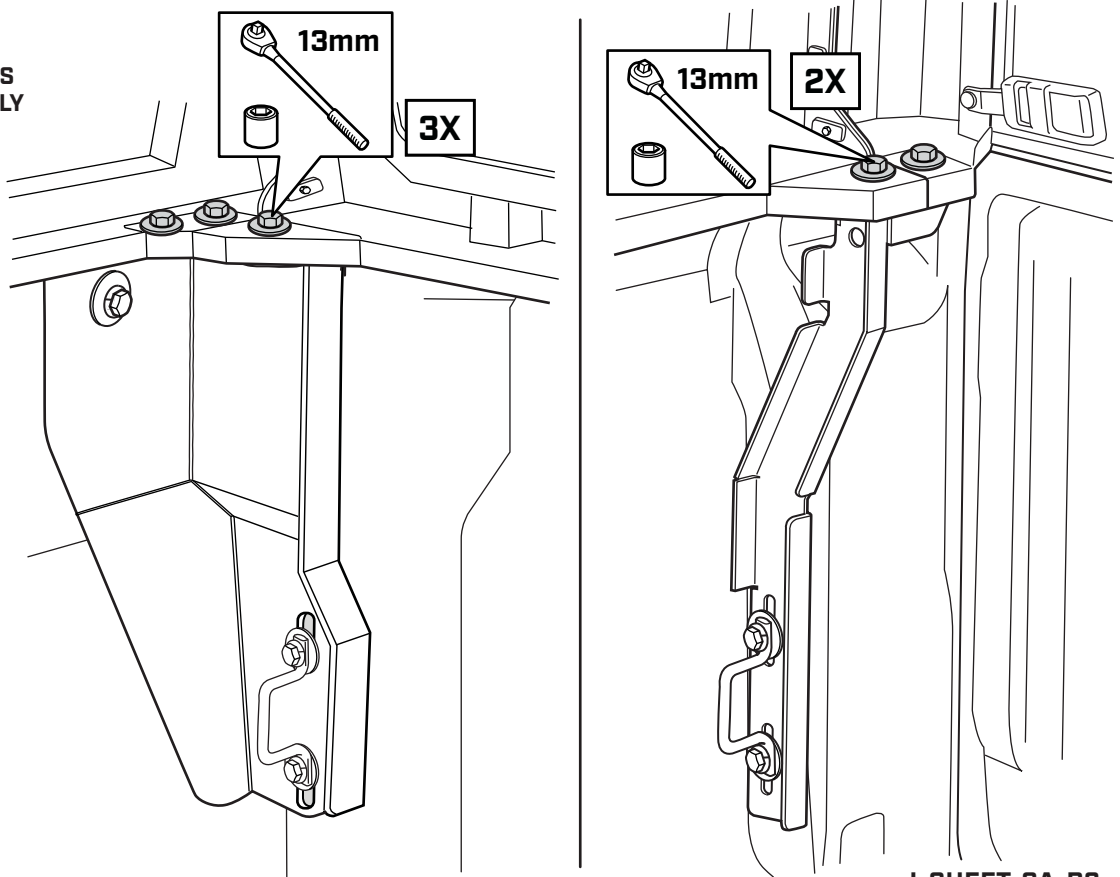

I-SHEET-SA-R2

STEP 36

PRESS DOWN ON THE SMARTCAP TO ACHIEVE 2MM - 3MM COMPRESSION ON THE D-RUBBER AND CONTINUE TIGHTENING BRACKET FASTENERS WITH SOCKET WRENCH AS INDICATED.

CONTINUE TIGHTENING FASTENERS ON ALL FOUR CORNERS OF THE VEHICLE.

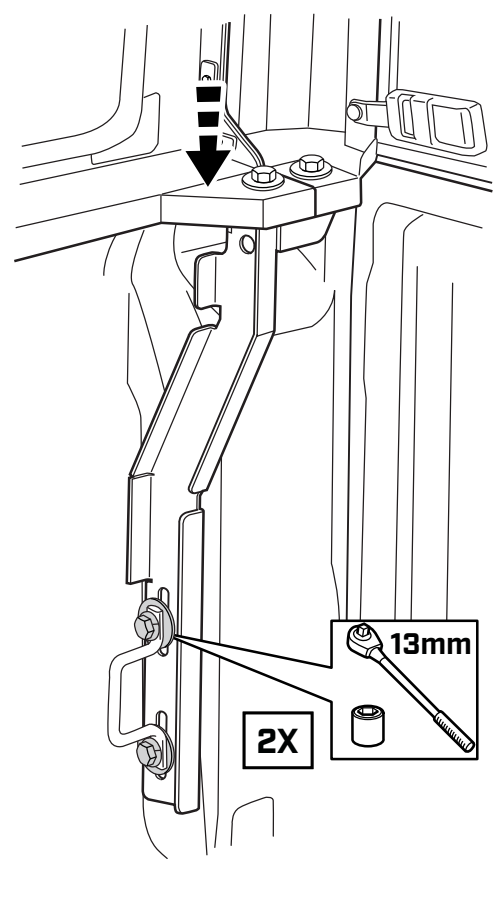
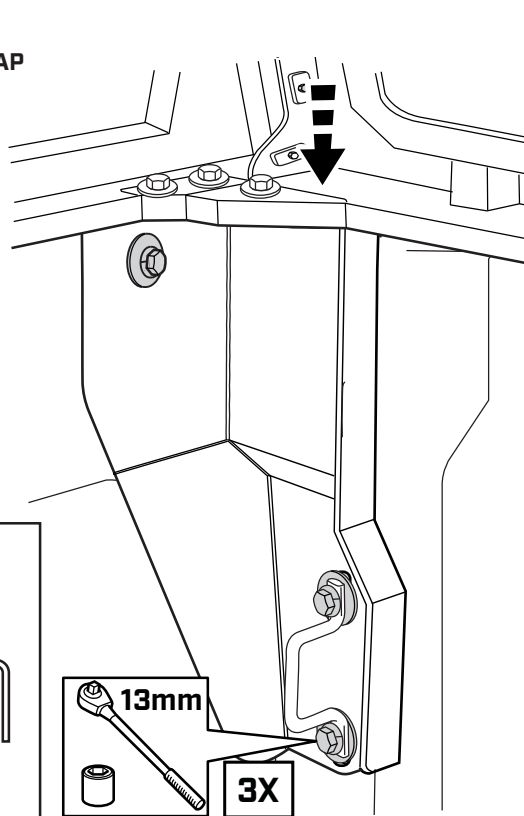
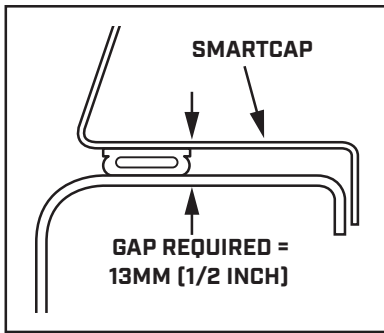

STEP 37

ONCE SMARTCAP IS POSITIONED CORRECTLY, FULLY TIGHTEN UPPER FASTENERS USING A TORQUE WRENCH AND 13MM SOCKET TO 4.4 FT. LBS [6 NEWTON METERS]

FULLY TIGHTEN UPPER FASTENERS ON ALL FOUR CORNERS OF THE VEHICLE.

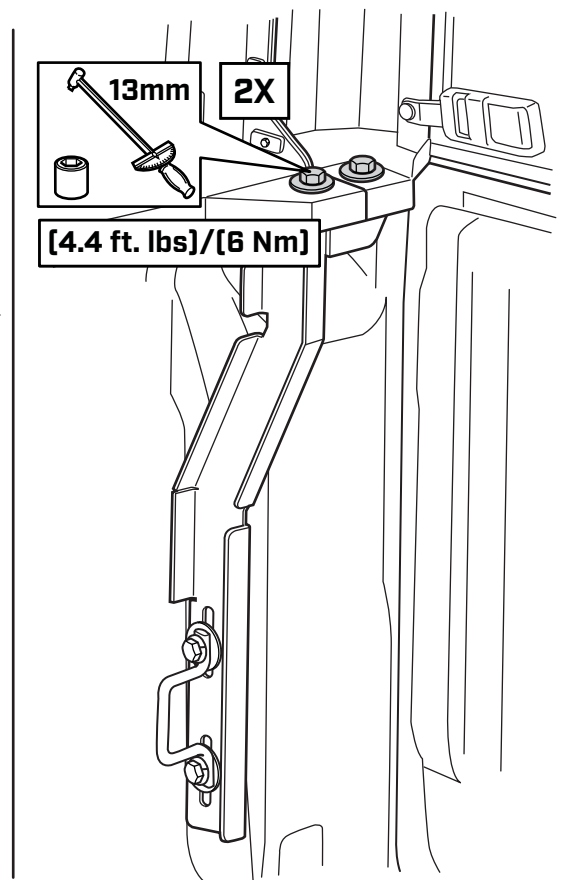
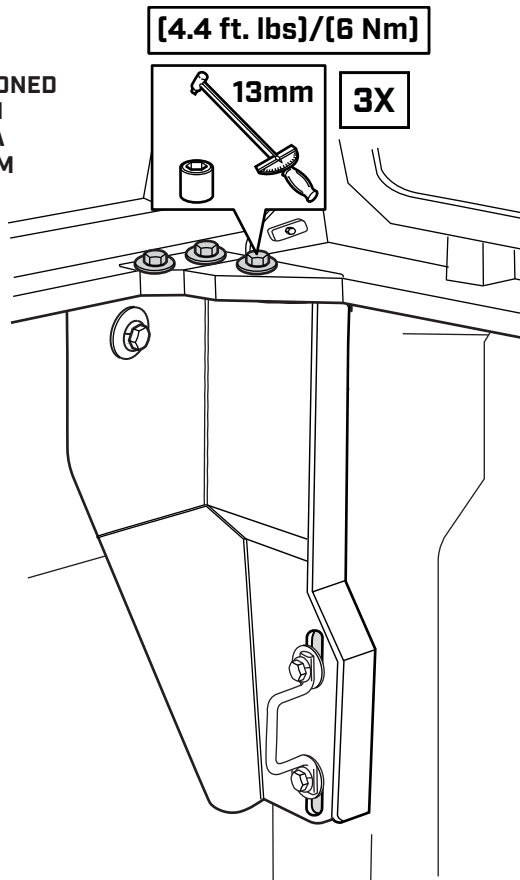

STEP 38

ONCE SMARTCAP IS POSITIONED CORRECTLY, FULLY TIGHTEN LOWER FASTENERS USING A TORQUE WRENCH AND 13MM SOCKET TO 9 FT. LBS [12.2 NEWTON METERS]

FULLY TIGHTEN LOWER FASTENERS ON ALL FOUR CORNERS OF THE VEHICLE.

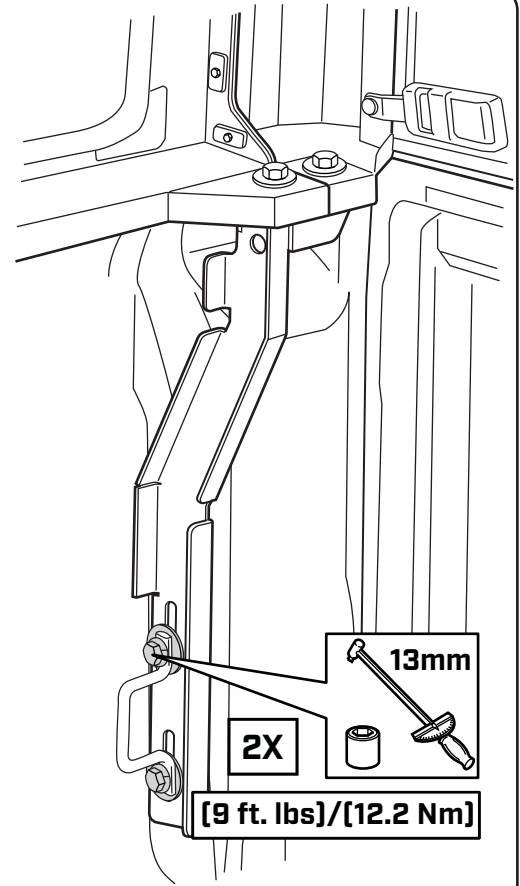
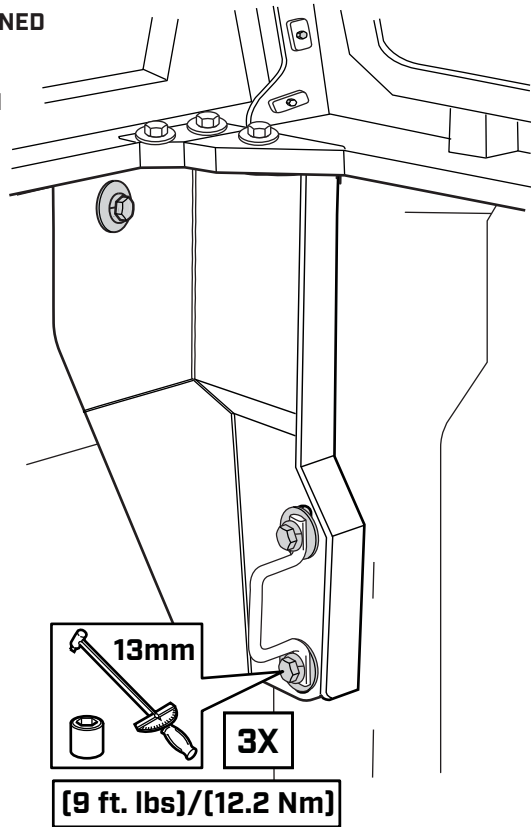

STEP 39

FULLY TIGHTEN THE M8 BUTTON HEAD BOLTS ALONG THE SIDE RAIL ATTACHMENT POINTS OF THE CAP USING A TORQUE WRENCH AND A 5MM HEX KEY BIT TO 4.4 FT. LBS. [6 NEWTON METERS].

REPEAT ON THE OPPOSITE SIDE OF THE VEHICLE.

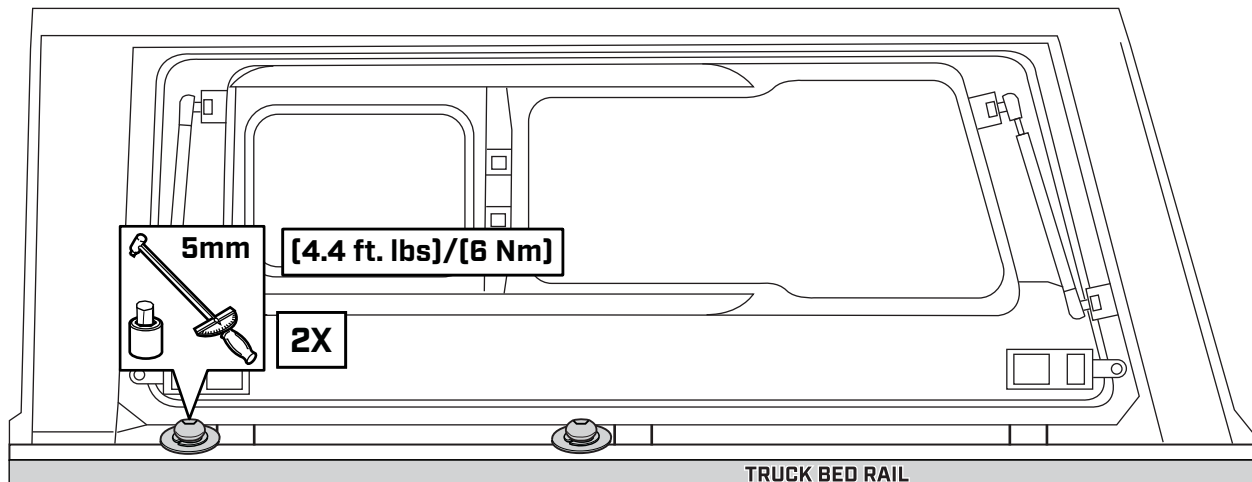

I-SHEET-SA-R2

SMARTCAP[®]

**THANKS FOR YOUR PURCHASE.
PLEASE LET US KNOW IF YOU HAVE ANY QUESTIONS.**

SMARTCAP.COM
SUPPORT.SA@SMARTCAP.COM - REST OF WORLD
SUPPORT.NA@SMARTCAP.COM - NORTH AMERICA/CANADA

