

SMARTCAP®

INSTRUCTION GUIDE FORD RANGER EDITION 2023-CURRENT (5th Generation)

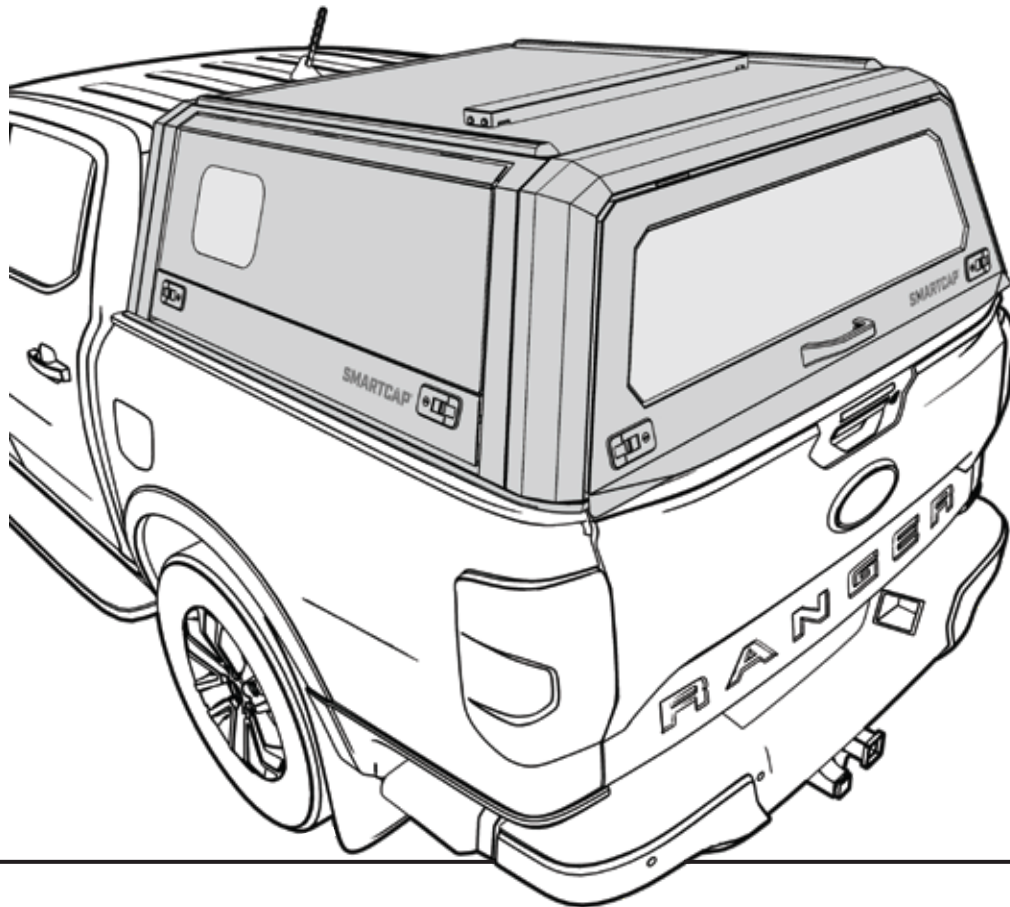

- ▼ **PREPARE A CLEAN WORK AREA.**
- ▼ **WE RECOMMEND A MINIMUM OF 2 PEOPLE FOR ASSEMBLY AND 4 PEOPLE FOR INSTALLATION**
- ▼ **ENSURE THE REQUIRED TOOLS ARE PRESENT AND ALL HARDWARE CONTENTS ARE ACCOUNTED FOR.**
- ▼ **NEVER USE ACETONE OR THINNERS ON PAINTED PARTS.**
- ▼ **READ THROUGH THE ENTIRE INSTRUCTION GUIDE BEFORE STARTING THIS PROCEDURE AND FOLLOW THE STEPS CAREFULLY TO AVOID ANY DAMAGE TO THE COMPONENTS OR THE VEHICLE.**

SMARTCAP.COM
SUPPORT.SA@SMARTCAP.COM - REST OF WORLD
SUPPORT.NA@SMARTCAP.COM - NORTH AMERICA/CANADA





DISCLAIMER

IT IS A REQUIREMENT FROM FORD THAT ANY 2024 NEXT GEN RANGER WITH ACCESSORIES EXTENDING ABOVE THE BEDRAILS, AND WEIGHING IN EXCESS OF 99LBS, BE FITTED WITH THEIR LOAD BOX REINFORCEMENT BRACKETS (AKA J-BRACES) PRIOR TO INSTALLATION, TO AVOID NEGATIVELY IMPACTING YOUR VEHICLE'S FACTORY WARRANTY. PLEASE CONSULT YOUR OWNER'S MANUAL OR SELLING DEALER FOR MOR INFORMATION.

J BRACE FITMENT WILL NOT BE NECESSARY FOR:

DOUBLE CAB RANGER AS FROM VIN: AFAARPF14SJ138520
DOUBLE CAB RAPTOR AS FROM VIN: 6FPFXMX2FRY37709

TOOLS REQUIRED

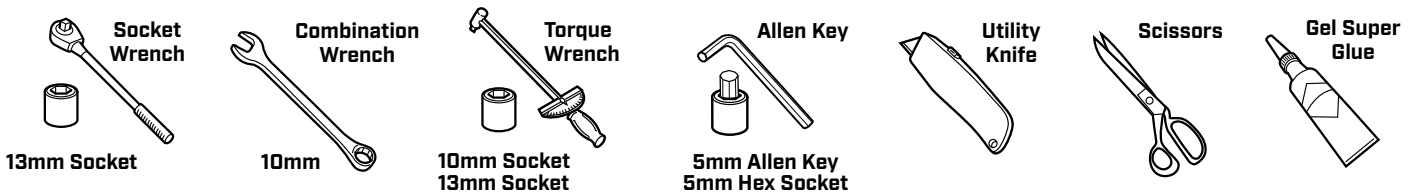

IMPORTANT

- ▼ USE ONLY THE TOOLS RECOMMENDED ABOVE.
- ▼ USE ONLY THE HARDWARE PROVIDED IN THIS KIT.
- ▼ ASSISTANCE WILL BE NEEDED FOR THIS INSTALLATION. FOUR PEOPLE ARE RECOMMENDED TO LIFT THE SMARTCAP ONTO THE VEHICLE.
- ▼ AVOID PINCHING OR CRUSHING HANDS AND FINGERS.
- ▼ INSPECT ALL KIT COMPONENTS FOR DAMAGE BEFORE ASSEMBLY.
- ▼ NEVER USE ACETONE OR THINNERS ON PAINTED PARTS.

COMPONENTS

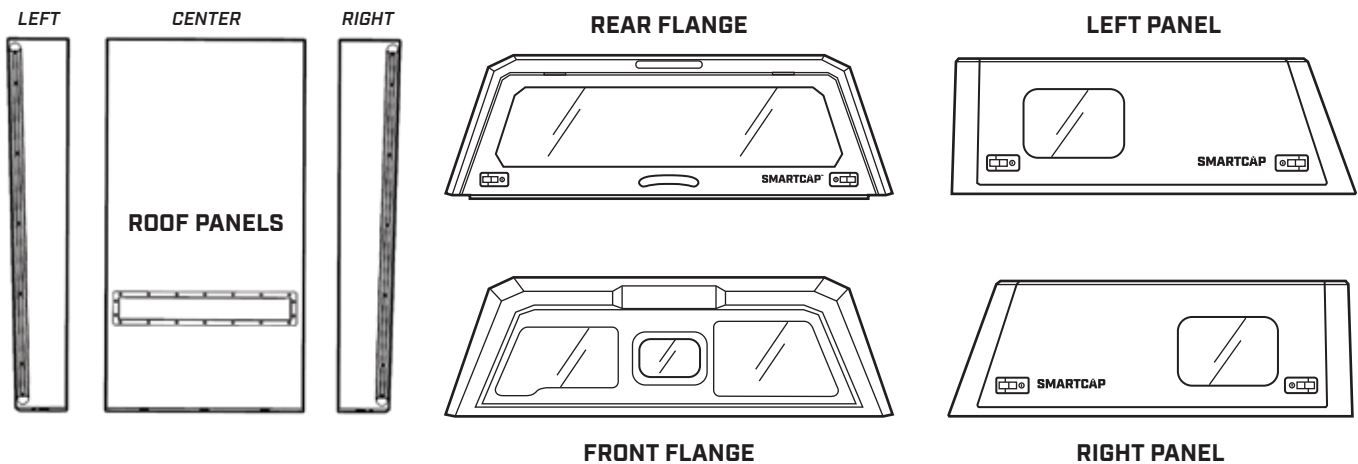

I-SHEET-SA-R3

ASSEMBLY HARDWARE

FITMENT KIT

M6 BOLT

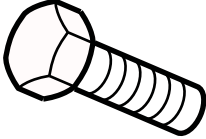

42X

**FASTENER
BLOCK CLAMP**

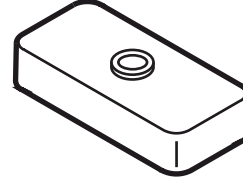

42X

M6 LOCK WASHER



42X

FASTENER BLOCK

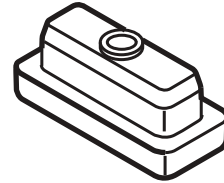

42X

D - RUBBER



1X

SPARE PARTS

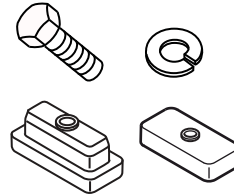

2X

**M6
FENDER WASHER**

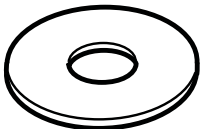

10X

M6 LOCK NUT

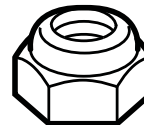

10X

STEP 1



IMPORTANT

▼ BE SURE TO REMOVE ALL SEVEN PANELS FROM THEIR PACKAGING AND INSPECT THE PAINTED SURFACES PRIOR TO ASSEMBLY, AS SMARTCAP WILL NOT ACCEPT WARRANTY CLAIMS AFTER ASSEMBLY IS COMPLETED. IF MANUFACTURING IMPERFECTIONS OR SHIPPING DAMAGES ARE FOUND, DO NOT CONTINUE WITH THE ASSEMBLY PROCESS AND CONTACT SUPPORT.NA@SMARTCAP.COM

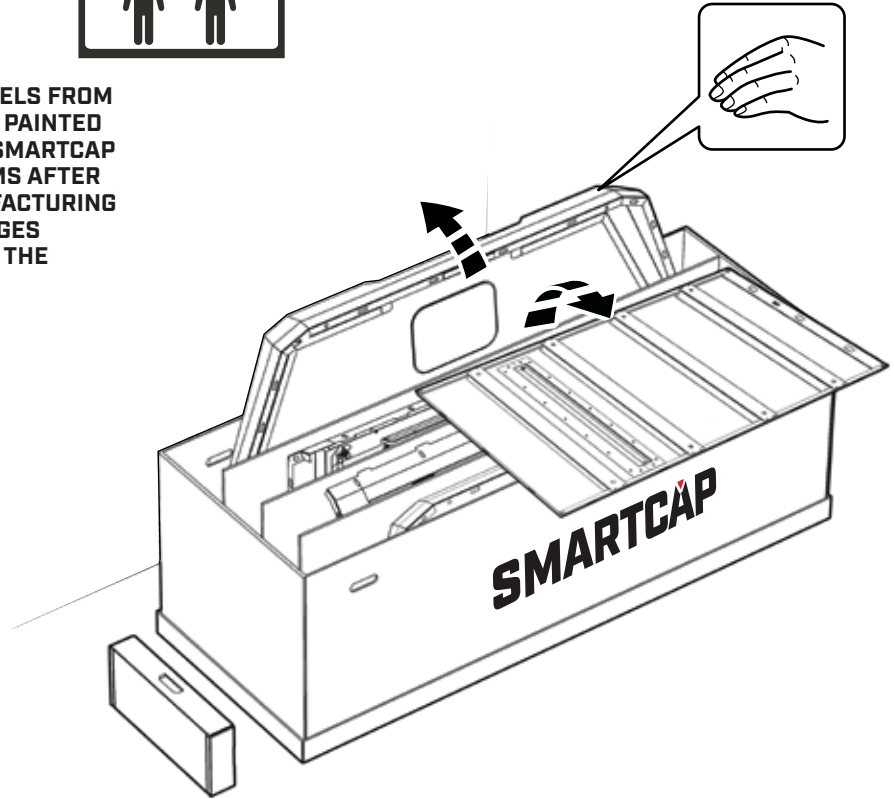

STEP 2

REMOVE THE FOUR CORNER STIFFENERS AND ONE OF THE CARDBOARD DIVIDERS TO BE USED AS A PROTECTIVE SURFACE DURING ASSEMBLY.

UNFOLD THE CARDBOARD DIVIDER AND PLACE IT WHERE YOU PLAN TO ASSEMBLE YOUR CAP.

PLACE THE FOUR CORNER STIFFENERS AS SHOWN BELOW.

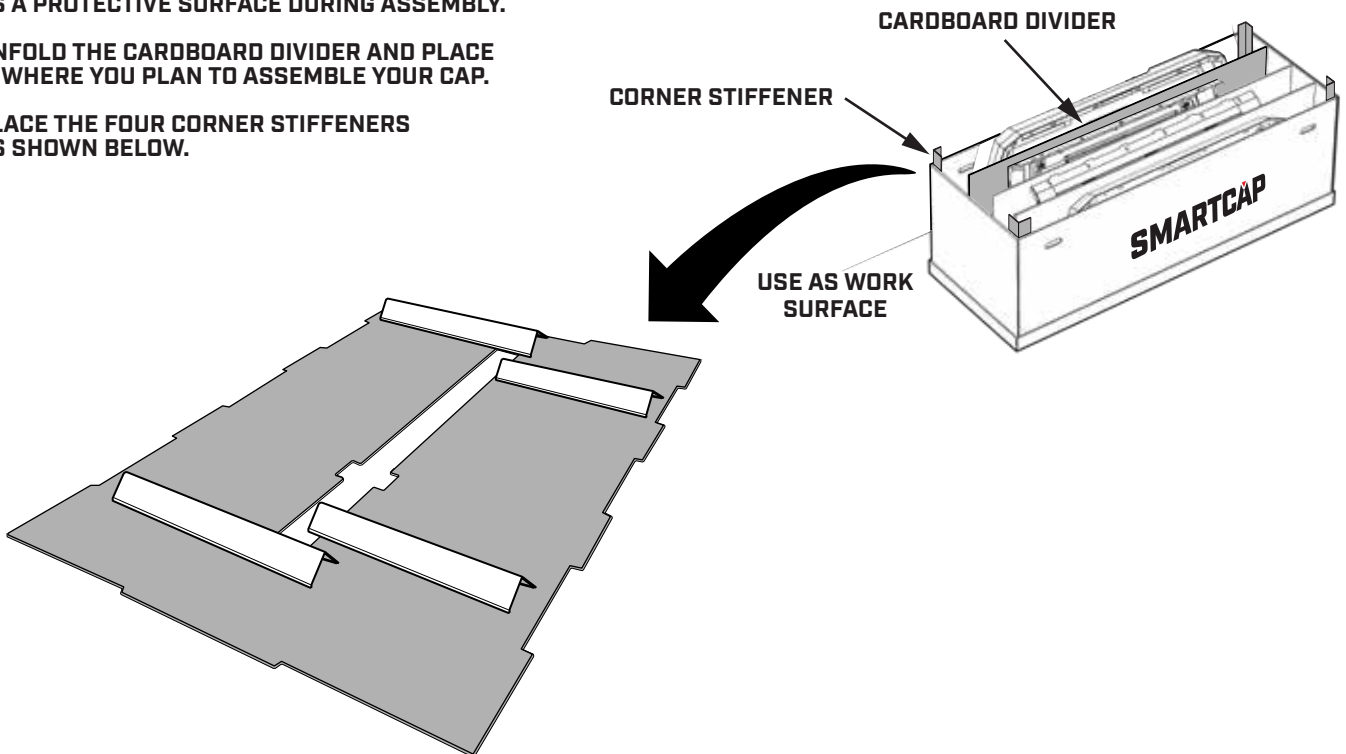

I-SHEET-NA-R3

STEP 3

PLACE THE ROOF PANELS ON TOP OF THE CORNER STIFFENERS, WITH THE BOTTOM OF THE ROOF PANELS FACING UP.

ALIGN THE PANELS SO THAT THE PROFILE OF THE FRONT AND REAR EDGES MATCH.

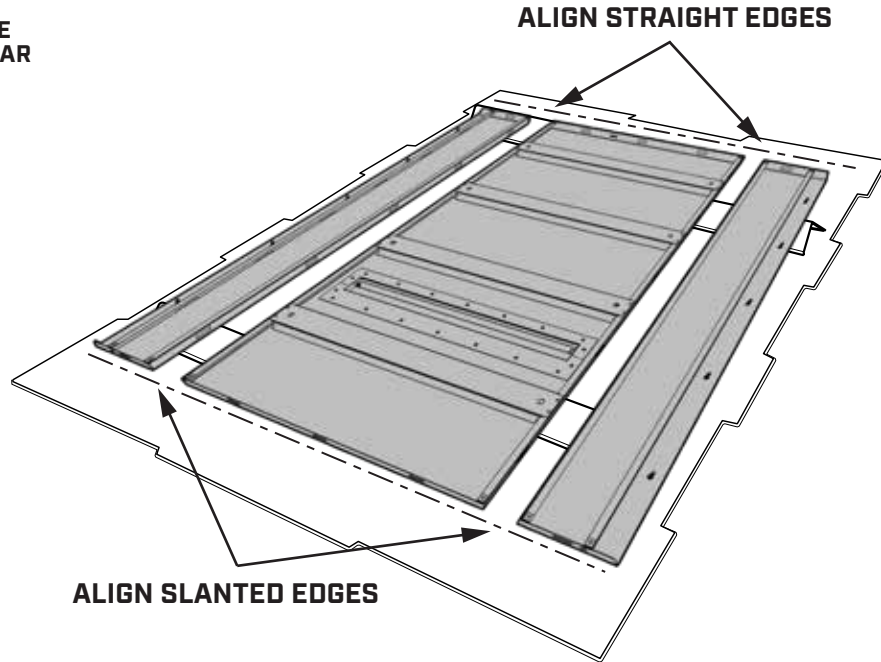

STEP 4

ASSEMBLE THE FASTENER BLOCKS TO THE ROOF PANELS USING A TORQUE WRENCH AND 10MM SOCKET TO 3.7 FT. LBS [5 NEWTON METERS].

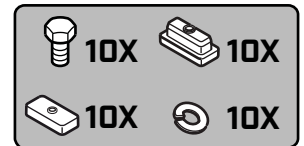

MAKE SURE ROOF PANELS ARE LEVEL

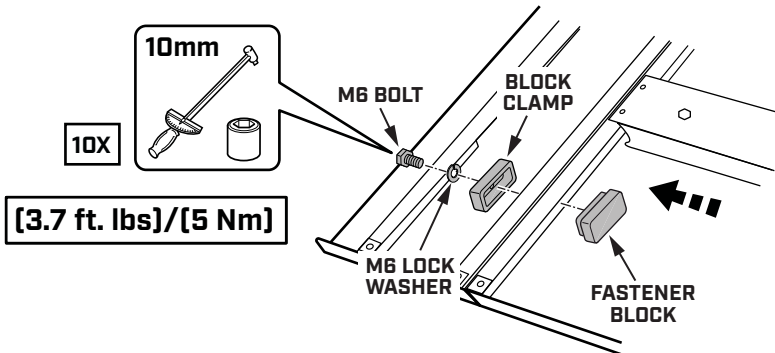
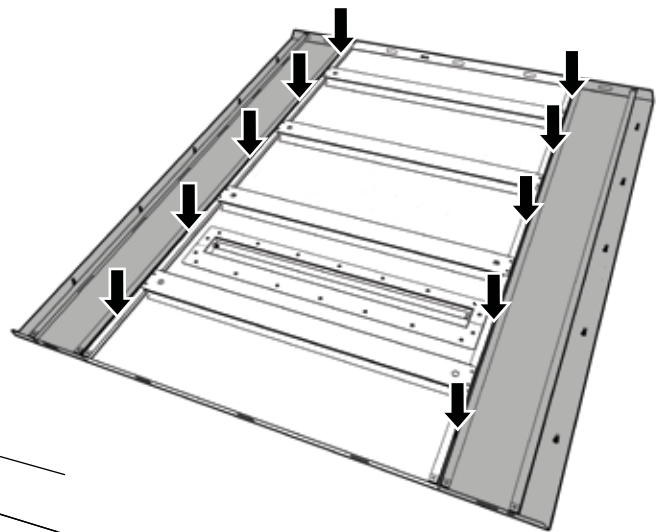

I-SHEET-NA-R3

STEP 5

USE A 10MM COMBINATION WRENCH TO REMOVE THE LOCK NUTS AND FENDER WASHERS FROM THE ROOF BOLTS AND SAVE FOR REUSE.



AIR VENT INDICATES REAR

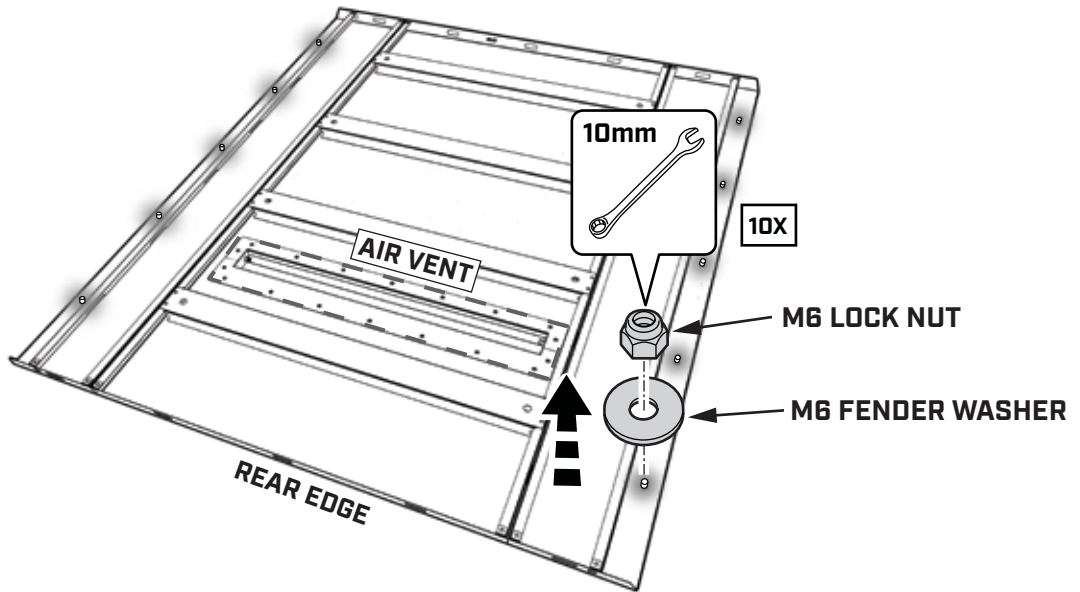

STEP 6

RETRIEVE THE FASTENER BLOCKS FROM THE FITMENT KIT AND PLACE 15 ON EACH SIDE OF THE ROOF PANEL.

TAKE APART THE FASTENER BLOCKS SO THEY ARE READY TO USE DURING ASSEMBLY.

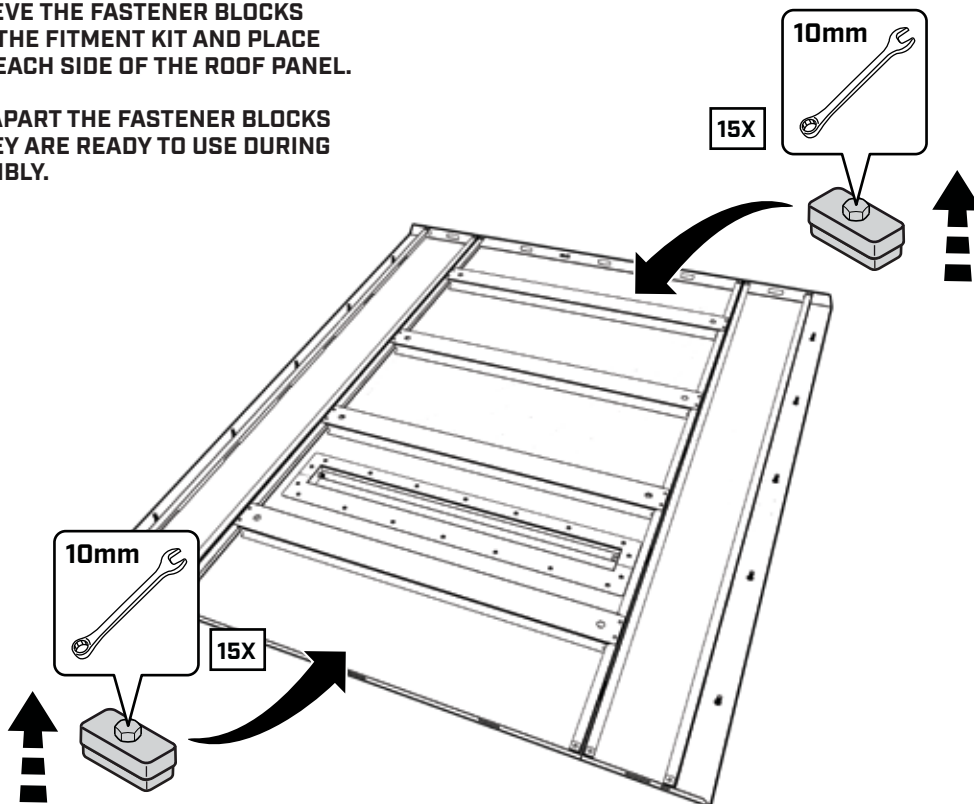
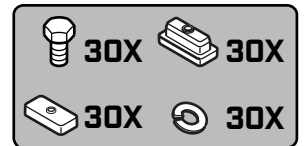

STEP 7

LOCATE THE RIGHT PANEL IN THE SMARTCAP PACKAGE AND BRING IT TO YOUR WORK AREA.



SLANTED EDGE INDICATES REAR

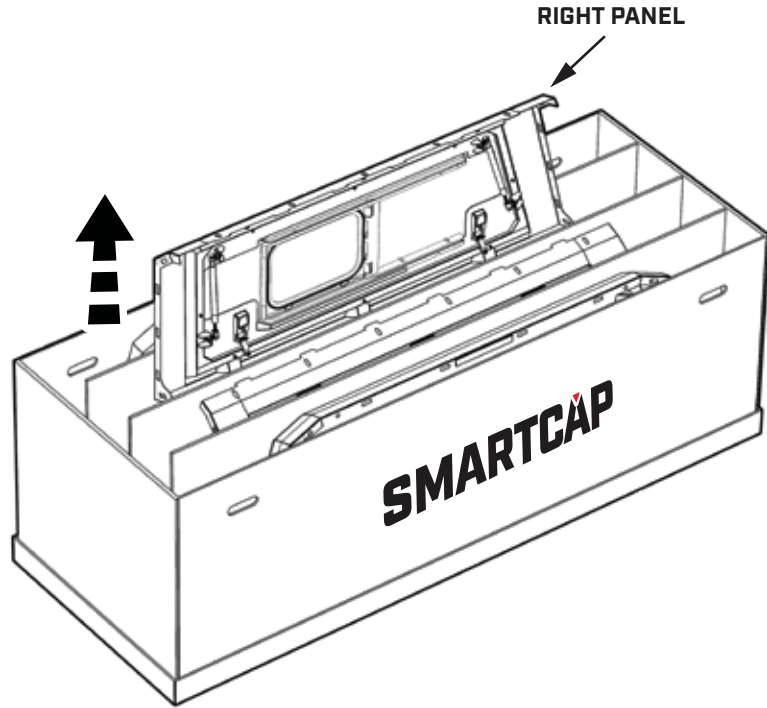

STEP 8

INSERT PANEL TABS INTO THE NARROW SLOTS JUST ABOVE FOAM PADDING ON ROOF PANEL.

TAP FIRMLY WITH PALM OF HAND UNTIL THERE IS A 2-3MM GAP.

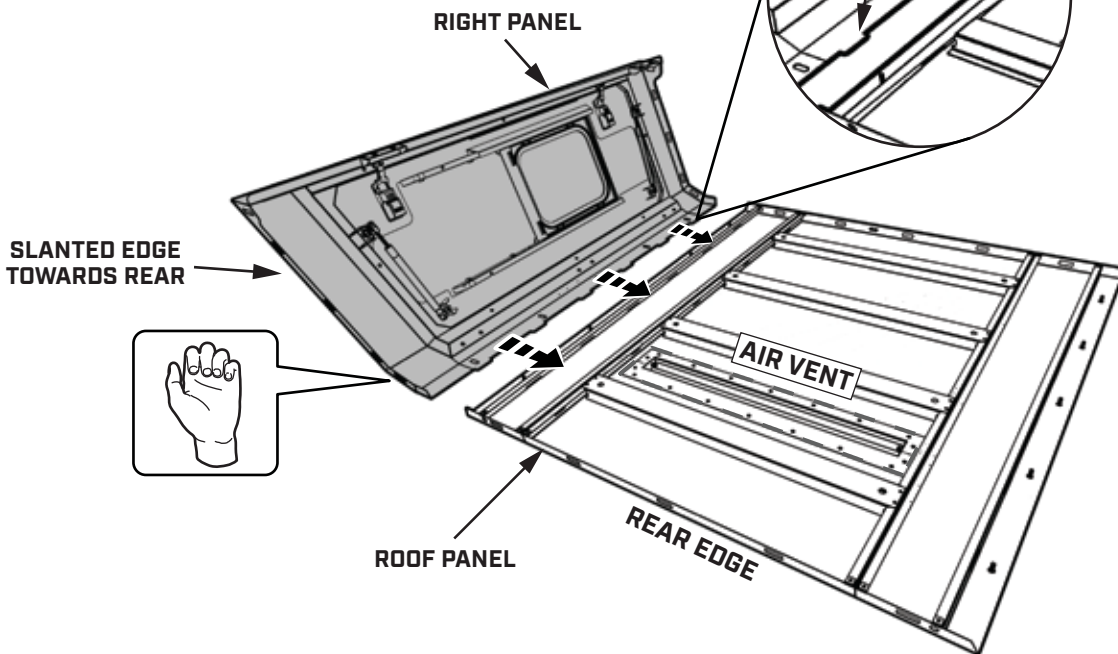
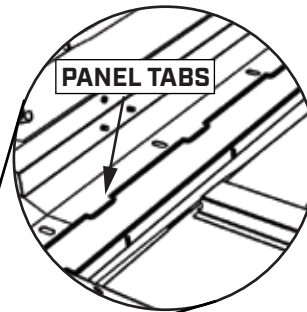

I-SHEET-NA-R3

STEP 9

HAND TIGHTEN M6 LOCK NUT WITH M6 FENDER WASHER TO ALL BOLTS.



SUPPORT RIGHT PANEL UNTIL ASSEMBLED TO FRONT FLANGE

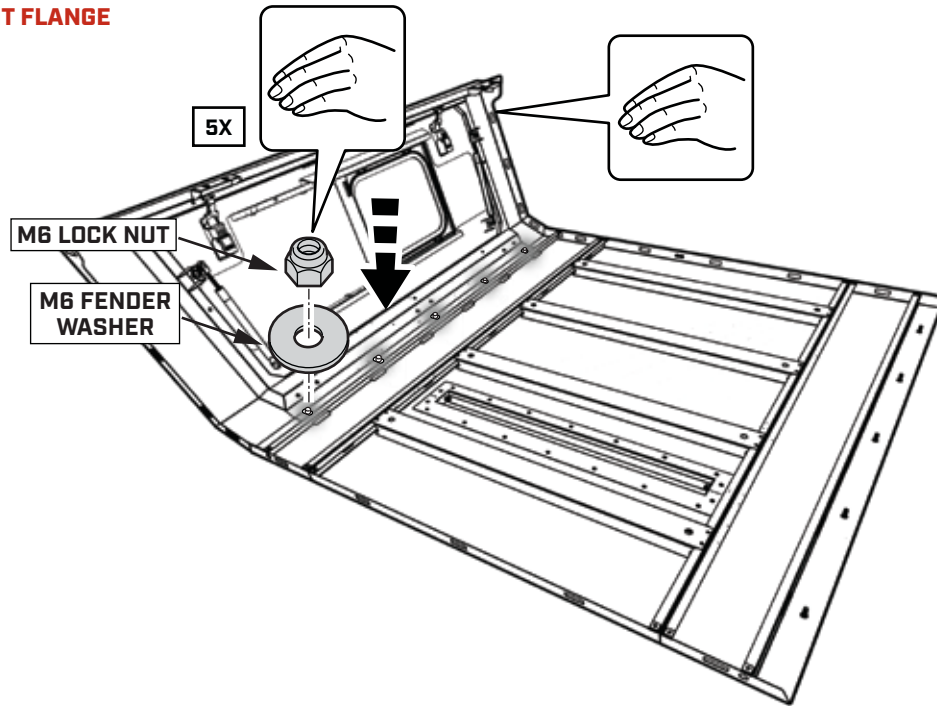

STEP 10

LOCATE THE FRONT FLANGE IN THE SMARTCAP PACKAGE AND BRING IT TO YOUR WORK AREA.

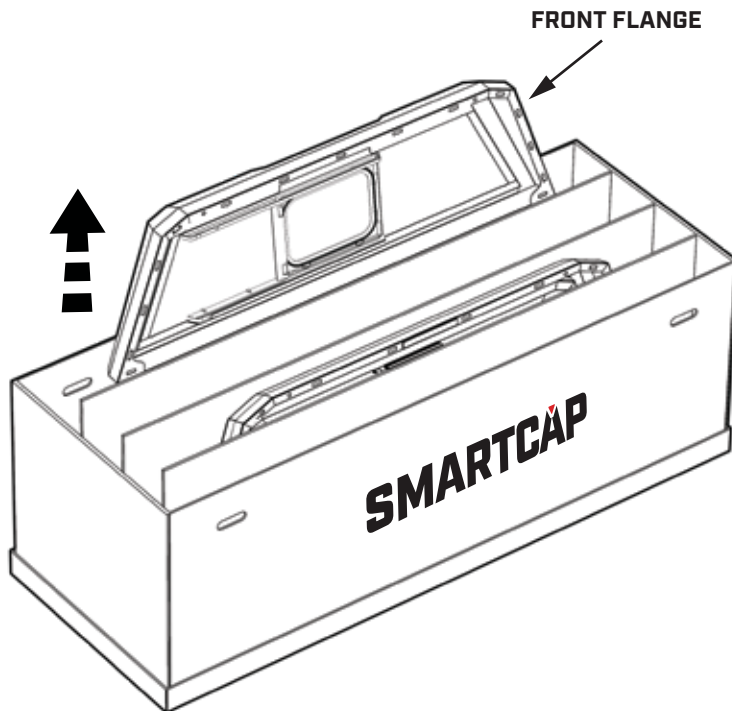

I-SHEET-NA-R3

STEP 11

PLACE FRONT FLANGE AS SHOWN BELOW.

HAND TIGHTEN TWO FASTENER BLOCKS AT THE INDICATED LOCATIONS TO SUPPORT THE RIGHT PANEL AND FRONT FLANGE.

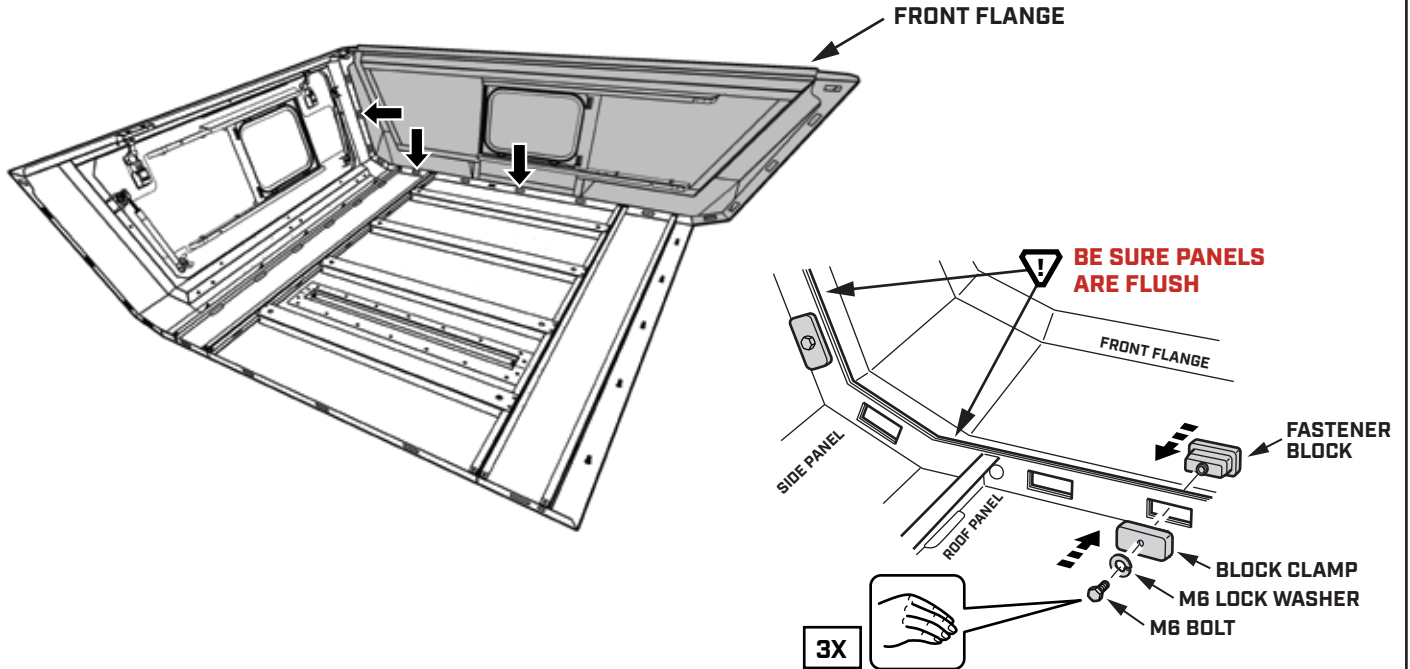

STEP 12

LOCATE THE LEFT PANEL IN THE SMARTCAP PACKAGE AND BRING IT TO YOUR WORK AREA.

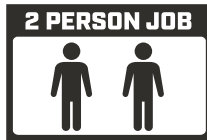

 **SLANTED EDGE INDICATES REAR**

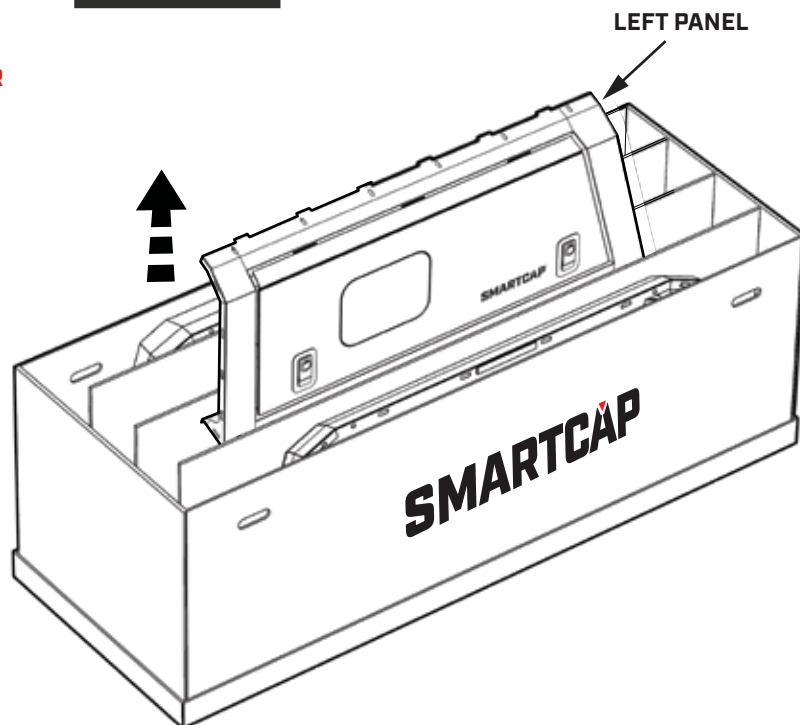

STEP 13

INSERT PANEL TABS INTO THE NARROW SLOTS JUST ABOVE FOAM PADDING ON ROOF PANEL.

TAP FIRMLY WITH PALM OF HAND UNTIL THERE IS A 2-3MM GAP.

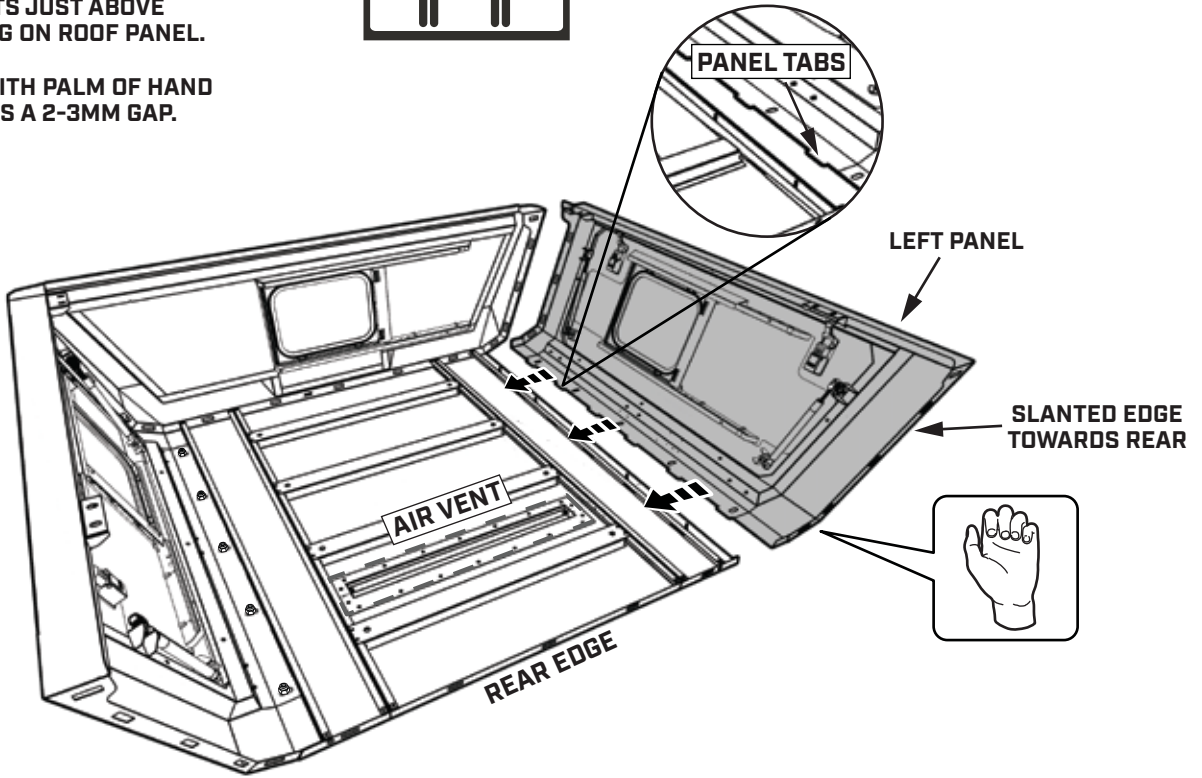

STEP 14

HAND TIGHTEN M6 LOCK NUT WITH M6 FENDER WASHER TO ALL BOLTS.

! SUPPORT LEFT PANEL UNTIL ASSEMBLED TO FRONT FLANGE

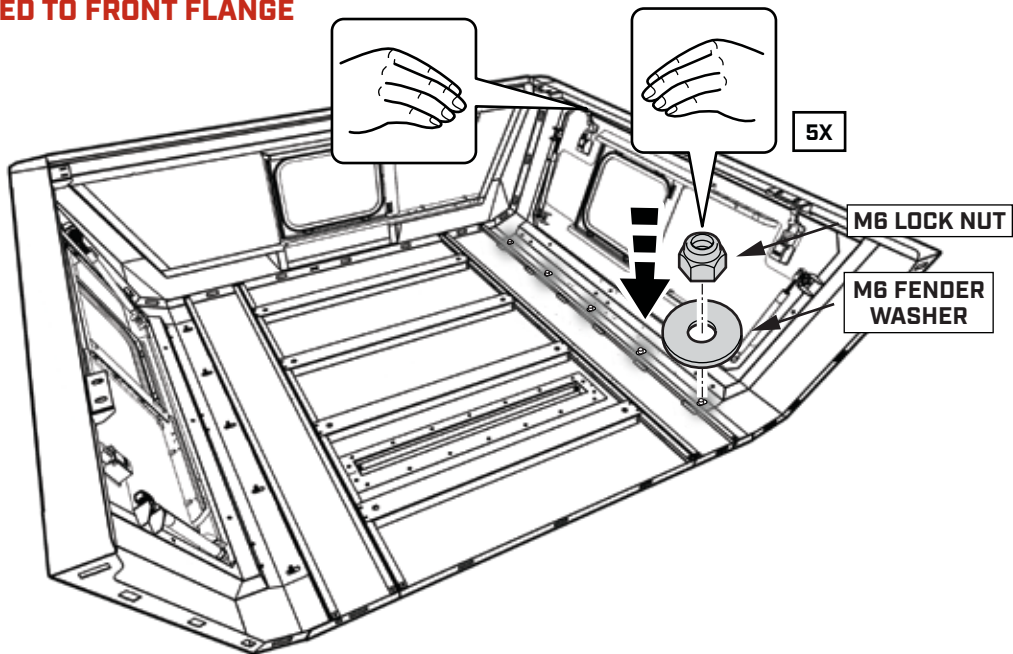

STEP 15

INSTALL HARDWARE ALONG FRONT FLANGE WITH BOLT ON INSIDE.

START AT CENTER OF THE FRONT FLANGE AND WORK YOUR WAY OUTWARDS.

ADJUST LEFT AND RIGHT PANELS TO ALIGN THE FASTENER BLOCK HOLES.

HAND TIGHTEN ONLY.

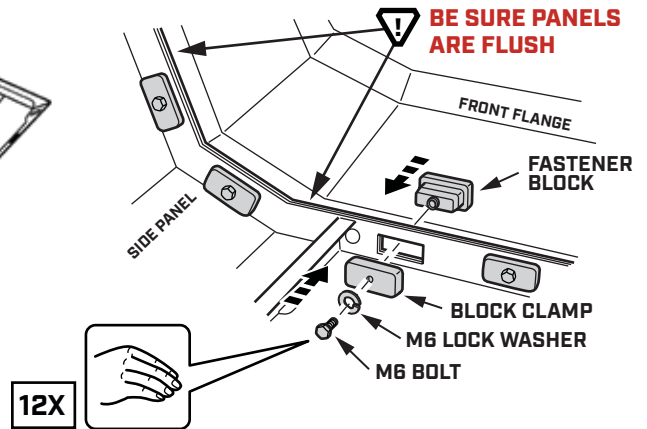
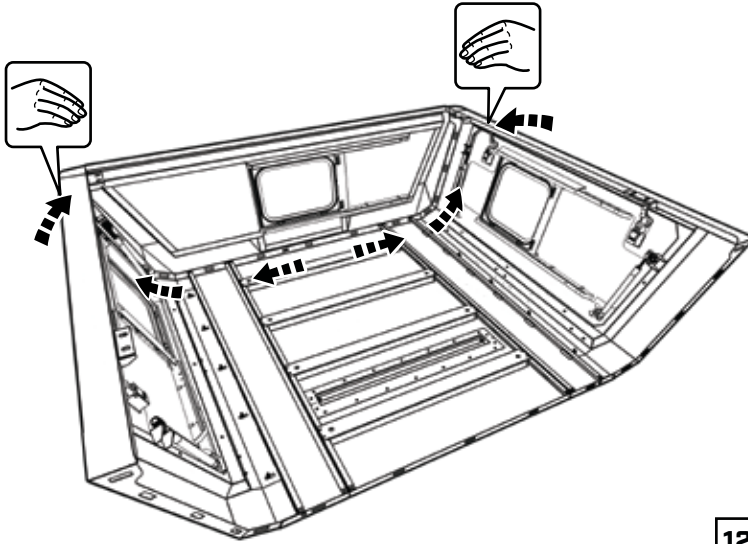
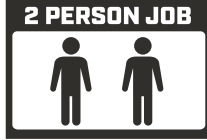

STEP 16

LOCATE THE REAR FLANGE IN THE SMARTCAP PACKAGE AND BRING IT TO YOUR WORK AREA.

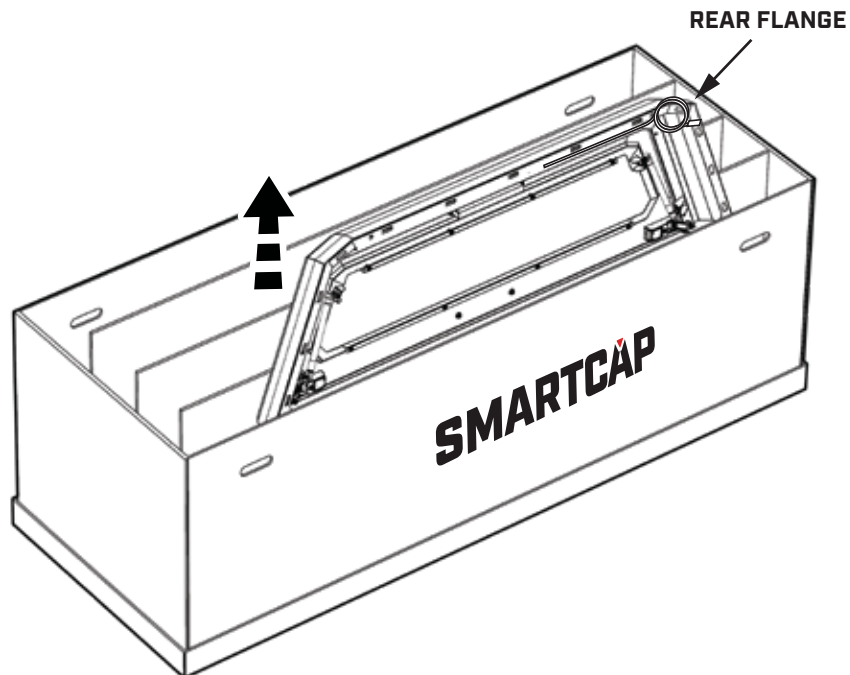

STEP 17

PLACE REAR FLANGE AS SHOWN BELOW.

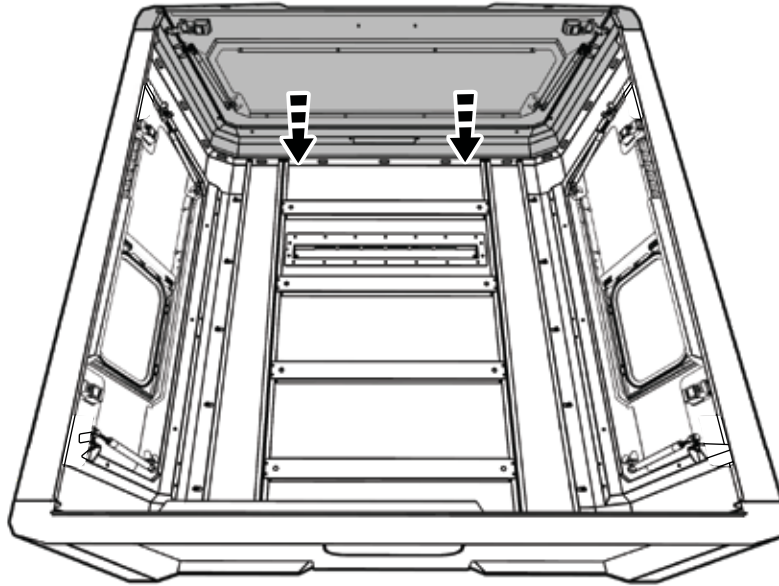

STEP 18

INSTALL HARDWARE ALONG REAR FLANGE WITH BOLT ON INSIDE.

START AT CENTER OF THE REAR FLANGE AND WORK YOUR WAY OUTWARDS.

ADJUST LEFT AND RIGHT PANELS TO ALIGN THE FASTENER BLOCK HOLES.

HAND TIGHTEN ONLY.

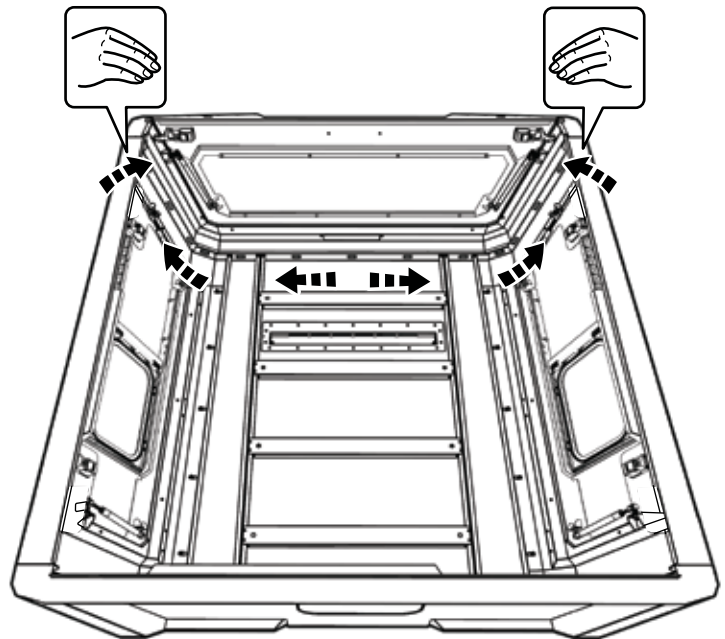
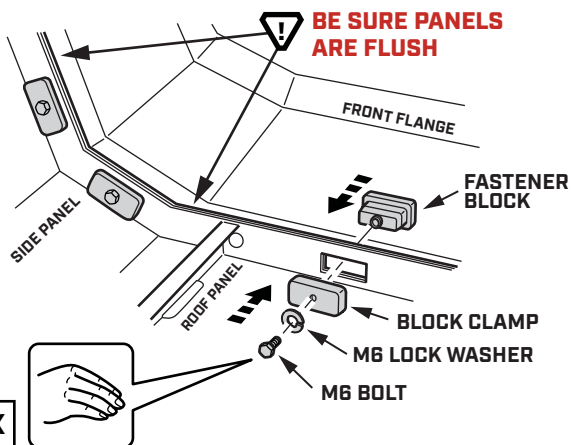

STEP 19

TIGHTEN ALL HARDWARE WITH TORQUE WRENCH AND 10MM SOCKET TO 3.7 FT. LBS. (5 NEWTON METERS)

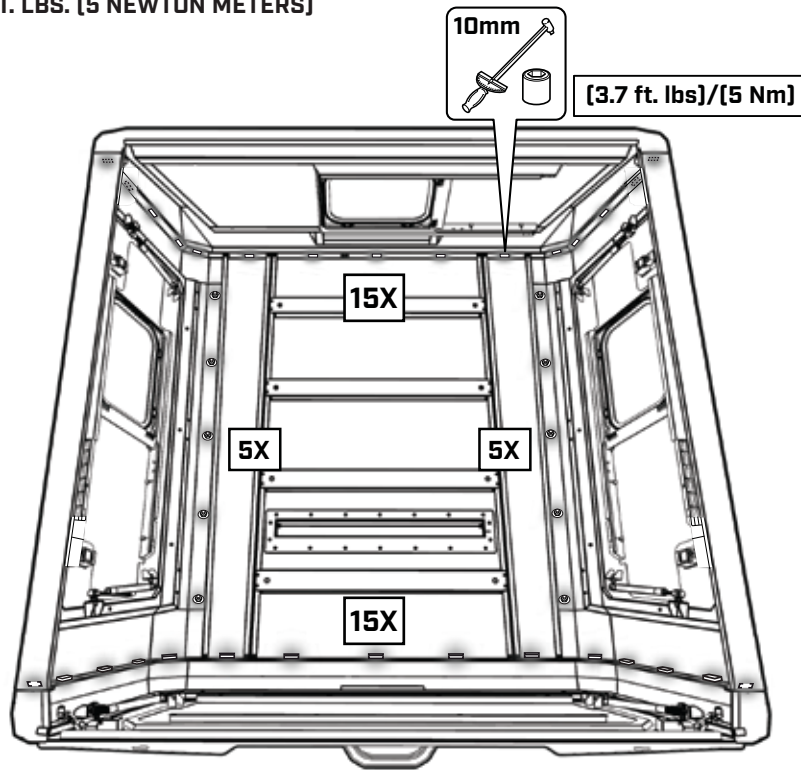

STEP 20

ENSURE THE ENTIRE BOTTOM EDGE OF THE SMARTCAP IS CLEAN.

LOCATE BOTH RETENTION TABS ON THE REAR FLANGE AND BEND EACH TO A 45-DEGREE ANGLE FOR D-RUBBER FITMENT.

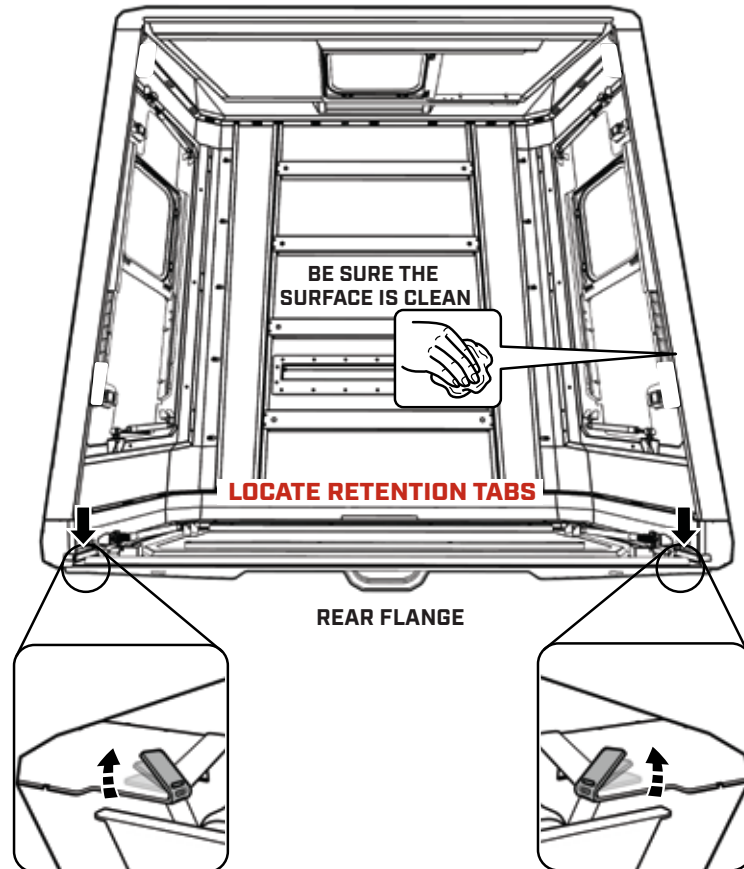

STEP 21



TRIM THE D-RUBBER WITH A CLEAN, STRAIGHT CUT.

APPLY 2-3 INCHES OF GEL SUPER GLUE NEAR THE RETENTION TABS, ALONG THE BOTTOM EDGE OF THE REAR FLANGE

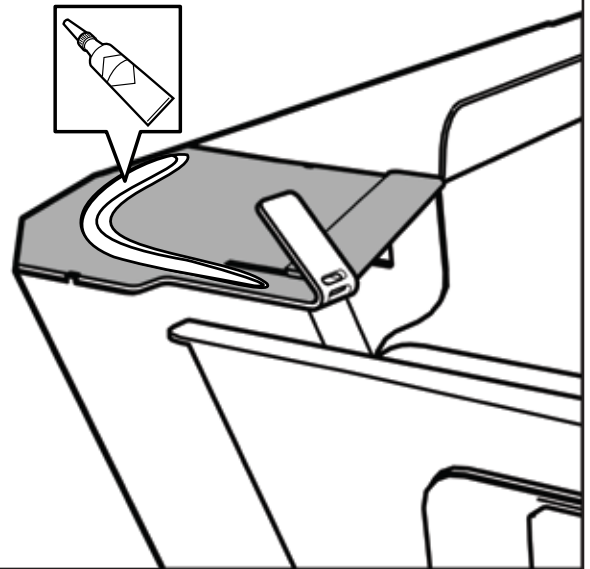
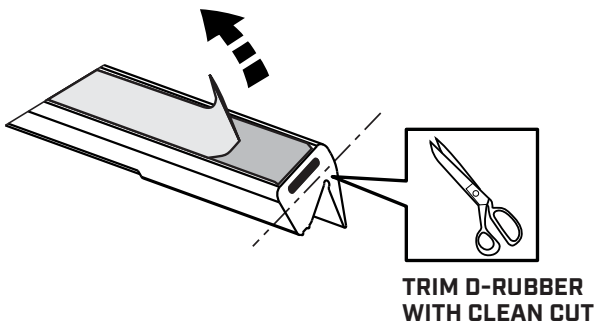

STEP 22

FULLY INSERT THE RETENTION TAB INTO THE SLOT ON THE D-RUBBER. ENSURE THE D-RUBBER IS ORIENTED CORRECTLY WITH ITS PROFILE MATCHING THE CONTOUR OF THE REAR FLANGE.

PRESS DOWN FIRMLY ON THE TAB AND THE D-RUBBER TO BOND IT TO THE REAR FLANGE, CREATING A TIGHT SEAL.

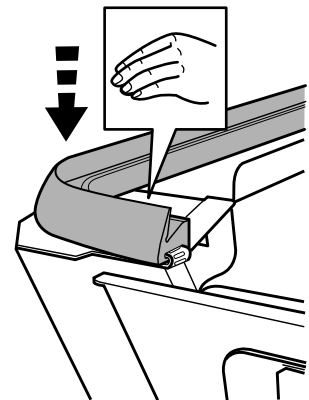
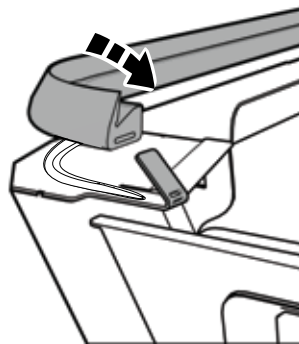

CORRECT D-RUBBER ORIENTATION

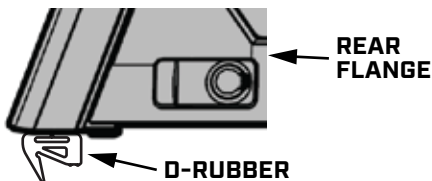

INCORRECT D-RUBBER ORIENTATION

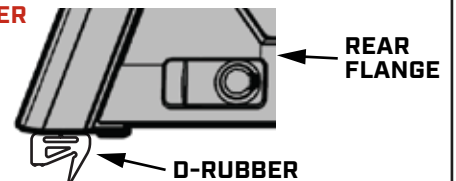

STEP 23

ALIGN THE D-RUBBER ALONG THE SMARTCAP'S EDGE, MAINTAINING A CONSISTENT 1/8 INCH GAP FROM THE EDGE.

START FROM ONE CORNER AND WORK YOUR WAY AROUND THE CAP TO ENSURE PROPER PLACEMENT AND ALIGNMENT.

REINFORCE CORNERS WITH GEL SUPER GLUE.

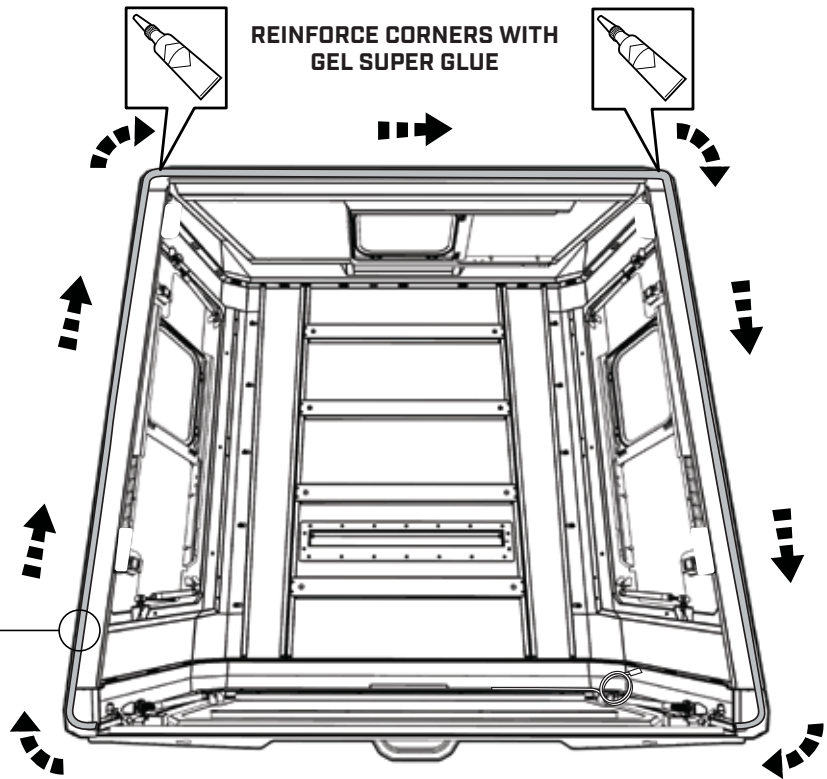
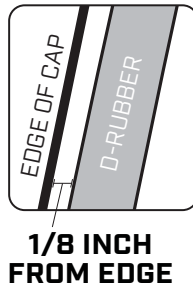

STEP 24

TRIM ANY EXCESS D-RUBBER BEYOND THE EDGE FOR A NEAT FINISH.

APPLY 2-3 INCHES OF SUPER GLUE NEAR THE RETENTION TAB, ALONG THE BOTTOM EDGE OF THE REAR FLANGE. FULLY INSERT THE RETENTION TAB INTO THE SLOT ON THE D-RUBBER.

PRESS DOWN FIRMLY ON THE TAB AND THE D-RUBBER TO BOND IT TO THE REAR FLANGE, CREATING A TIGHT SEAL.

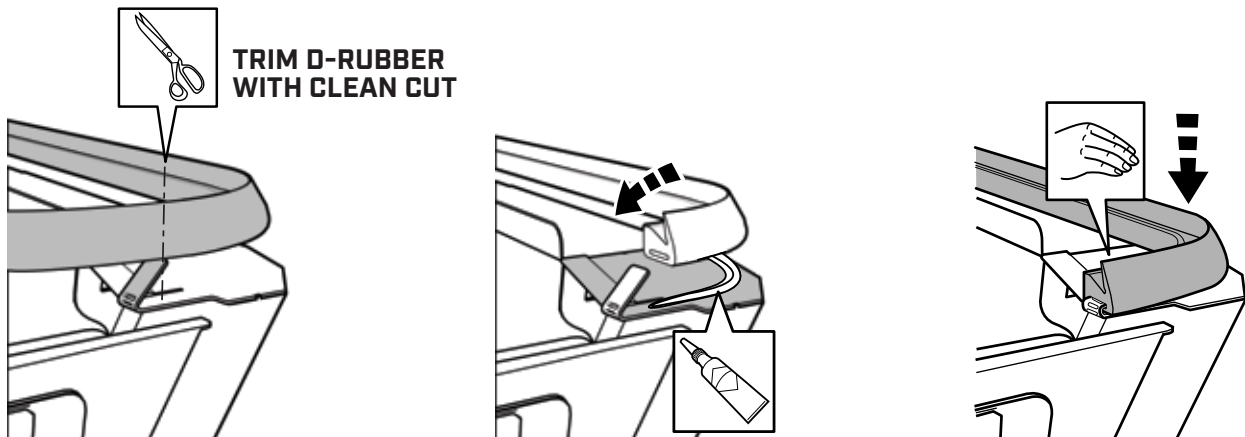

I-SHEET-NA-R3

INSTALLATION HARDWARE

MOUNTING BRACKETS

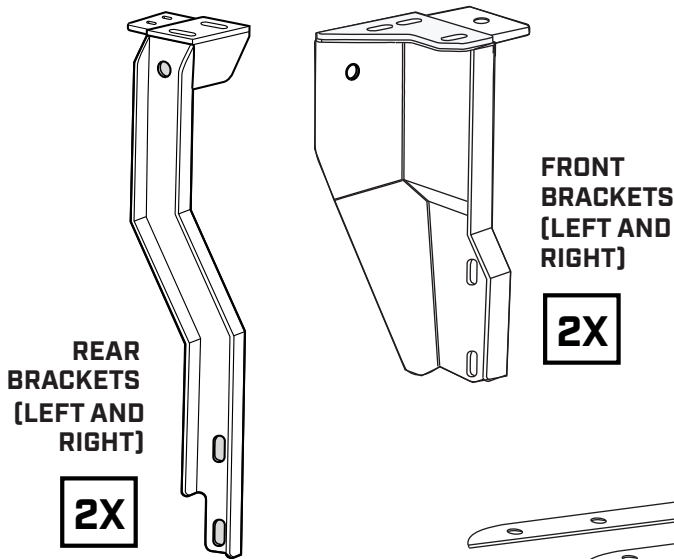

25mm x 25mm FOAM SEAL TAPE

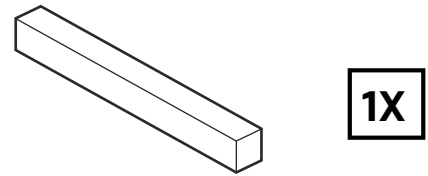
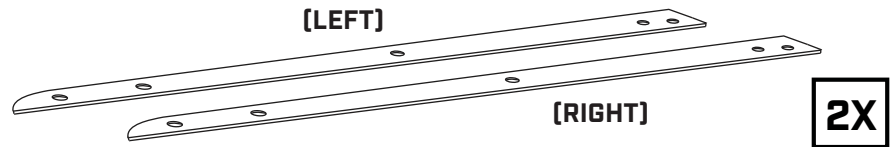
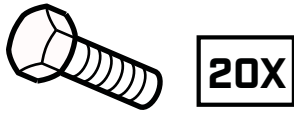

PLATE STRIPS



M8 x 20mm BOLT



M8 LOCK WASHER



M8 FENDER WASHER



M8 x 20mm BUTTON BOLT



M8 LOCK NUT



LOAD SPREADER

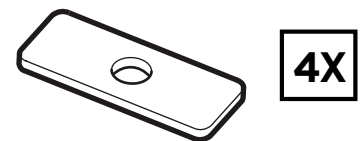

VEHICLE INSTALLATION

IMPORTANT

- ▼ ASSISTANCE WILL BE NEEDED FOR THIS INSTALLATION. FOUR PEOPLE ARE RECOMMENDED TO LIFT THE SMARTCAP ONTO THE VEHICLE.
- ▼ AVOID PINCHING OR CRUSHING HANDS AND FINGERS.
- ▼ READ THROUGH THE ENTIRE PROCEDURE BEFORE STARTING.

STEP 25

REMOVE THE PLASTIC BED-RAIL CAP INSERTS AND BED-RAIL CAPS.

REPEAT ON THE OPPOSITE SIDE OF THE VEHICLE.

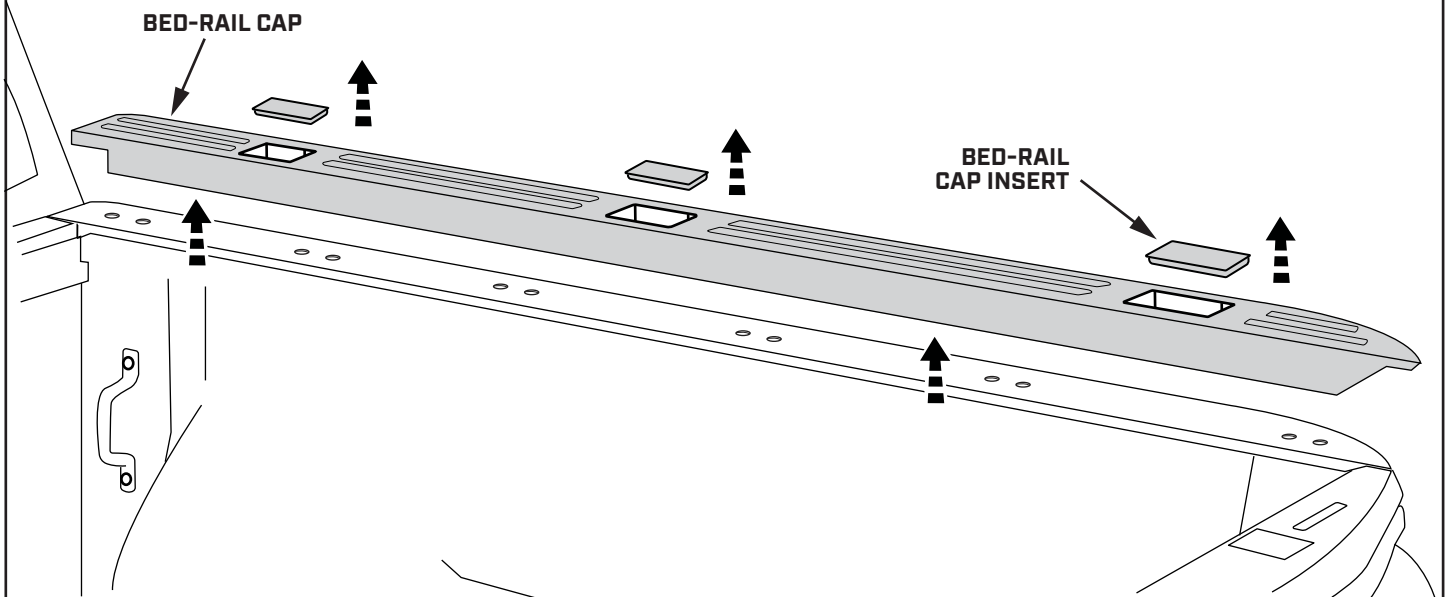

STEP 26

REMOVE THE ADHESIVE BACKING FROM THE PLATE STRIP AND APPLY TO THE BIN RAIL, ALIGNING THE FRONT OF THE PLATE STRIP TO THE FRONT OF THE BIN.

REPEAT ON THE OPPOSITE SIDE OF THE VEHICLE.

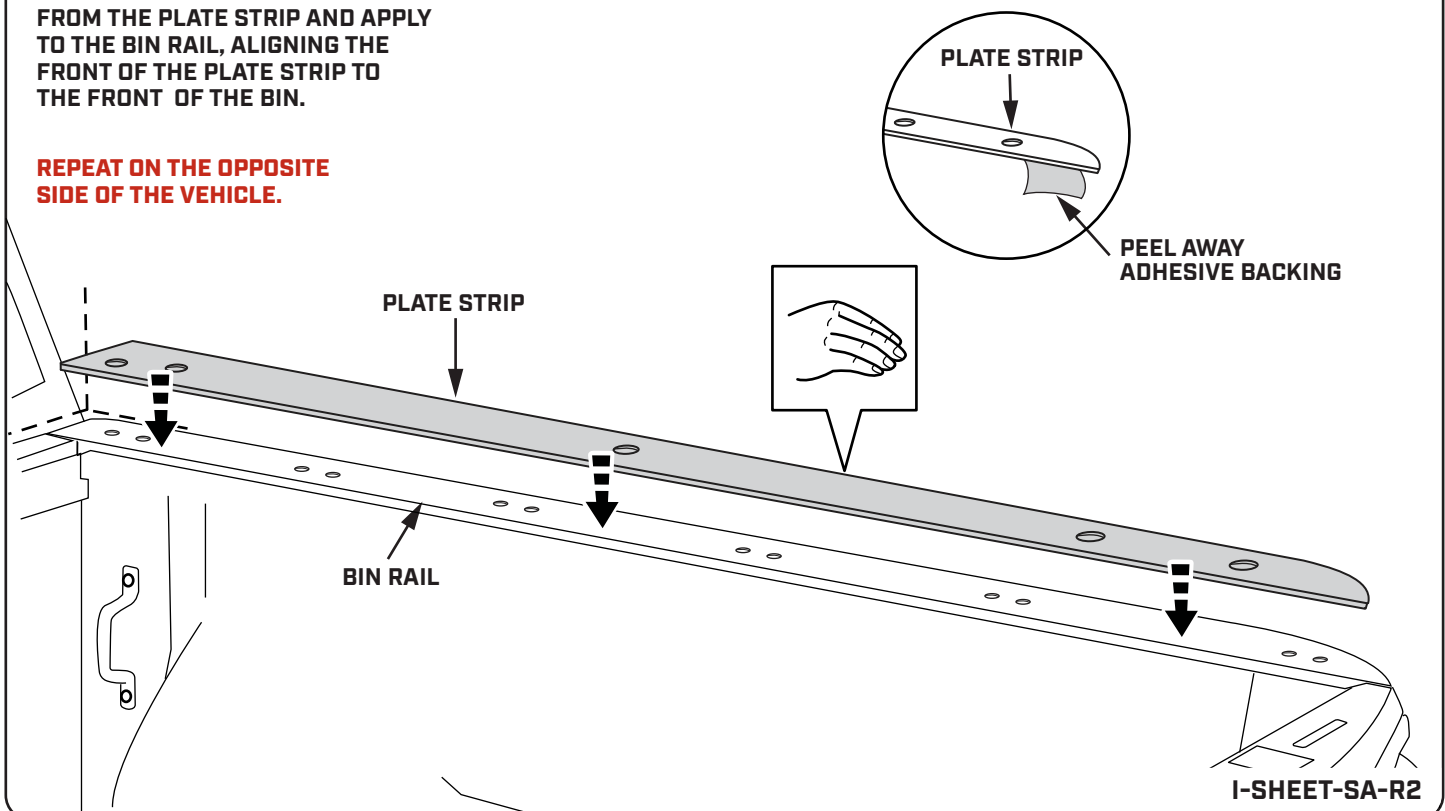

I-SHEET-SA-R2

STEP 27

INSPECT THE TRUCK BED. IF FRONT EDGE IS LOWER THAN THE SIDES, ADD FOAM SEAL TAPE TO THE FRONT EDGE OF THE BED.

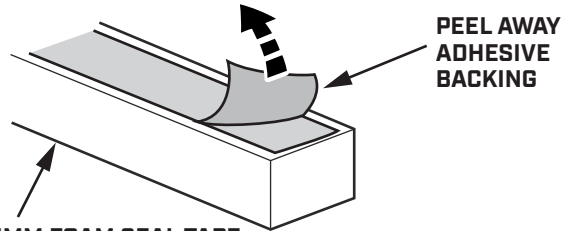
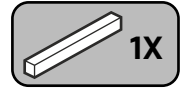

25MM x 25MM FOAM SEAL TAPE

PEEL AWAY
ADHESIVE
BACKING

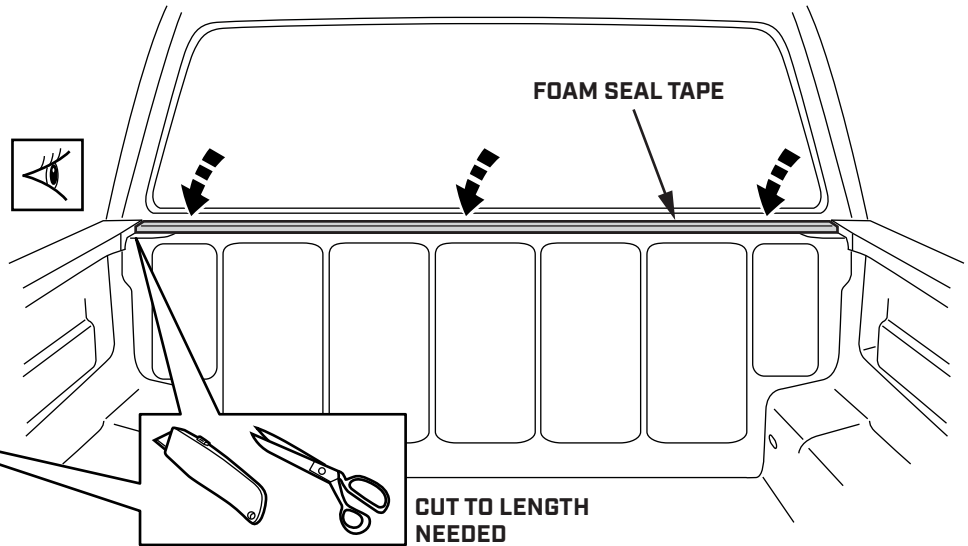

FOAM SEAL TAPE

CUT TO LENGTH
NEEDED

FULLY SEAL
AT BOTH ENDS

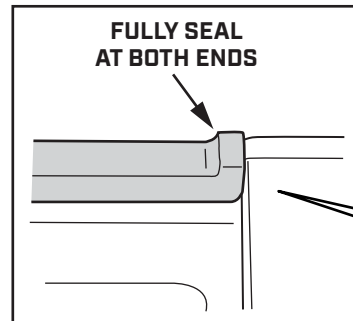

STEP 28

REMOVE THE FRONT TIE DOWN HOOK FROM THE INNER WALL OF THE TRUCK BED.

POSITION THE RIGHT SIDE FRONT MOUNTING BRACKET IN THE FRONT CORNER OF THE TRUCK BED AS SHOWN.

SECURE THE BRACKET WITH THE FASTENERS AS INDICATED, HAND TIGHTEN ONLY.

REPEAT ON THE OPPOSITE SIDE OF THE VEHICLE WITH THE LEFT FRONT MOUNTING BRACKET.

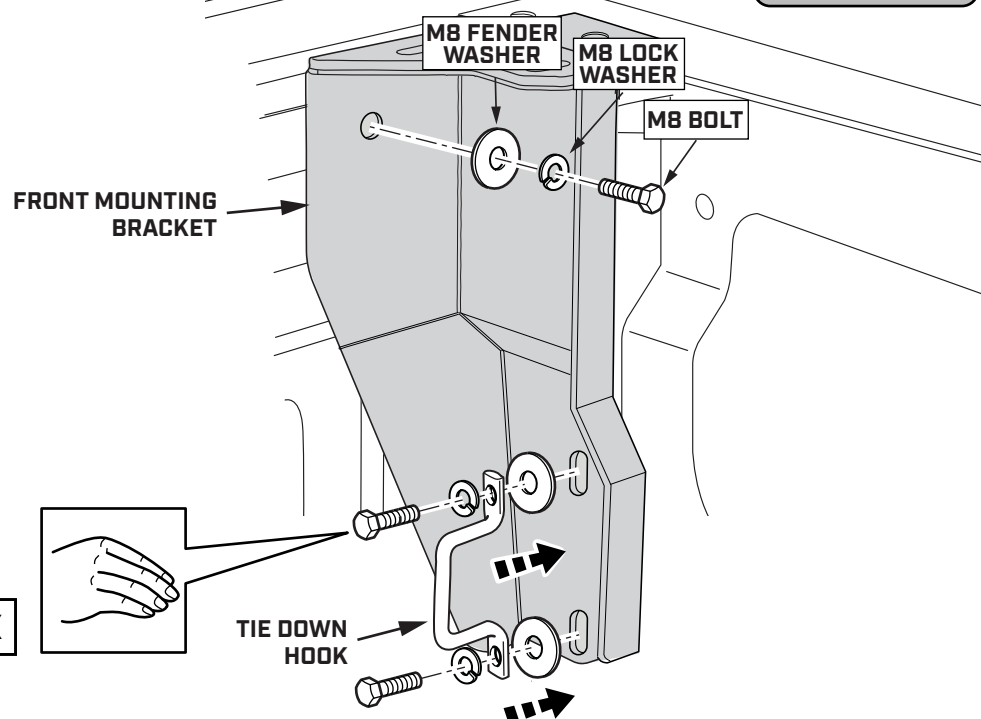
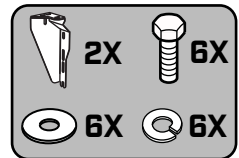

FRONT MOUNTING BRACKET

MB FENDER WASHER

MB LOCK WASHER

MB BOLT

3X

TIE DOWN HOOK

STEP 29

USE A 5MM ALLEN KEY TO FASTEN THE FRONT RIGHT MOUNTING BRACKET TO THE TOP OF THE TRUCK BED.

SECURE THE BRACKET WITH THE FASTENERS AS INDICATED.

REPEAT ON THE OPPOSITE SIDE OF THE VEHICLE WITH THE LEFT FRONT MOUNTING BRACKET.

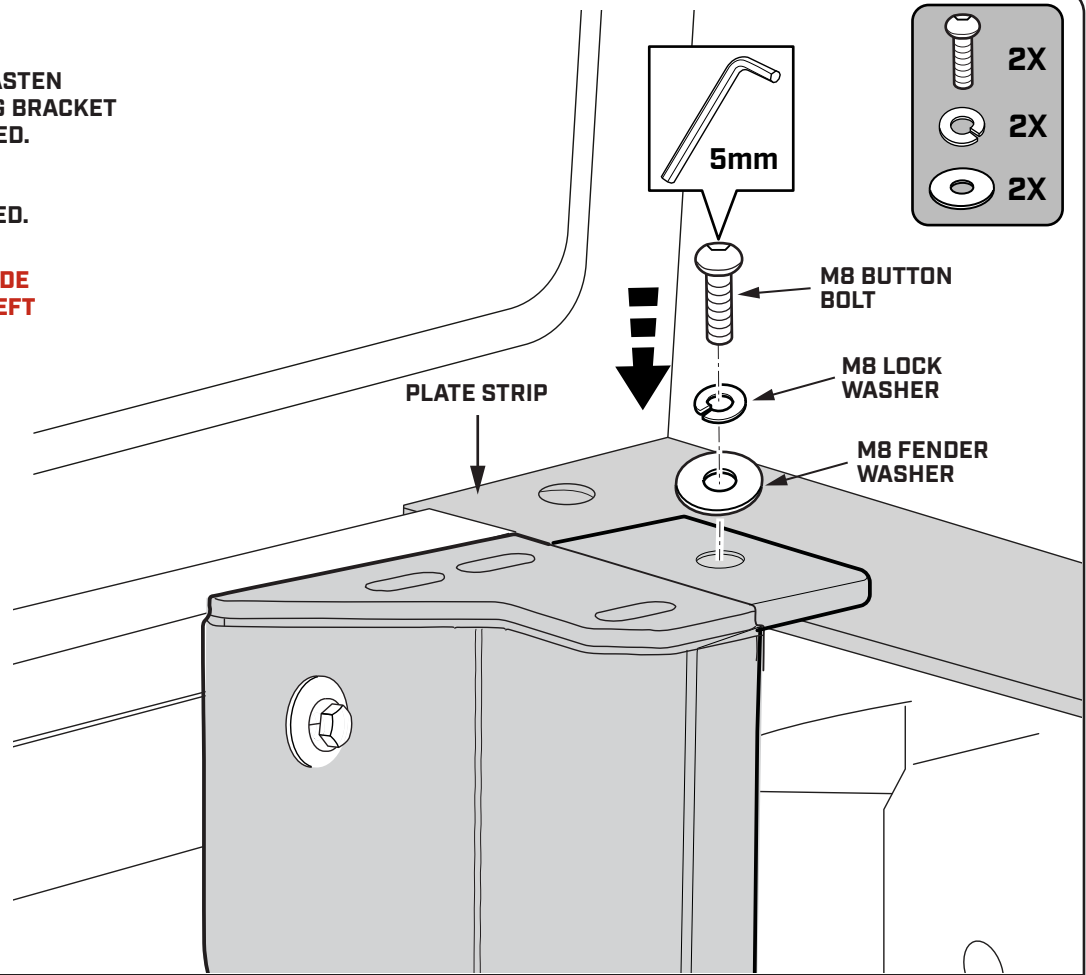

STEP 30

REMOVE THE REAR TIE DOWN HOOK FROM THE INNER WALL OF THE TRUCK BED.

POSITION THE RIGHT SIDE REAR MOUNTING BRACKET IN THE BACK CORNER OF THE TRUCK BED AS SHOWN.

SECURE THE BRACKET WITH THE FASTENERS AS INDICATED, HAND TIGHTEN ONLY.

REPEAT ON THE OPPOSITE SIDE OF THE VEHICLE WITH THE LEFT REAR MOUNTING BRACKET.

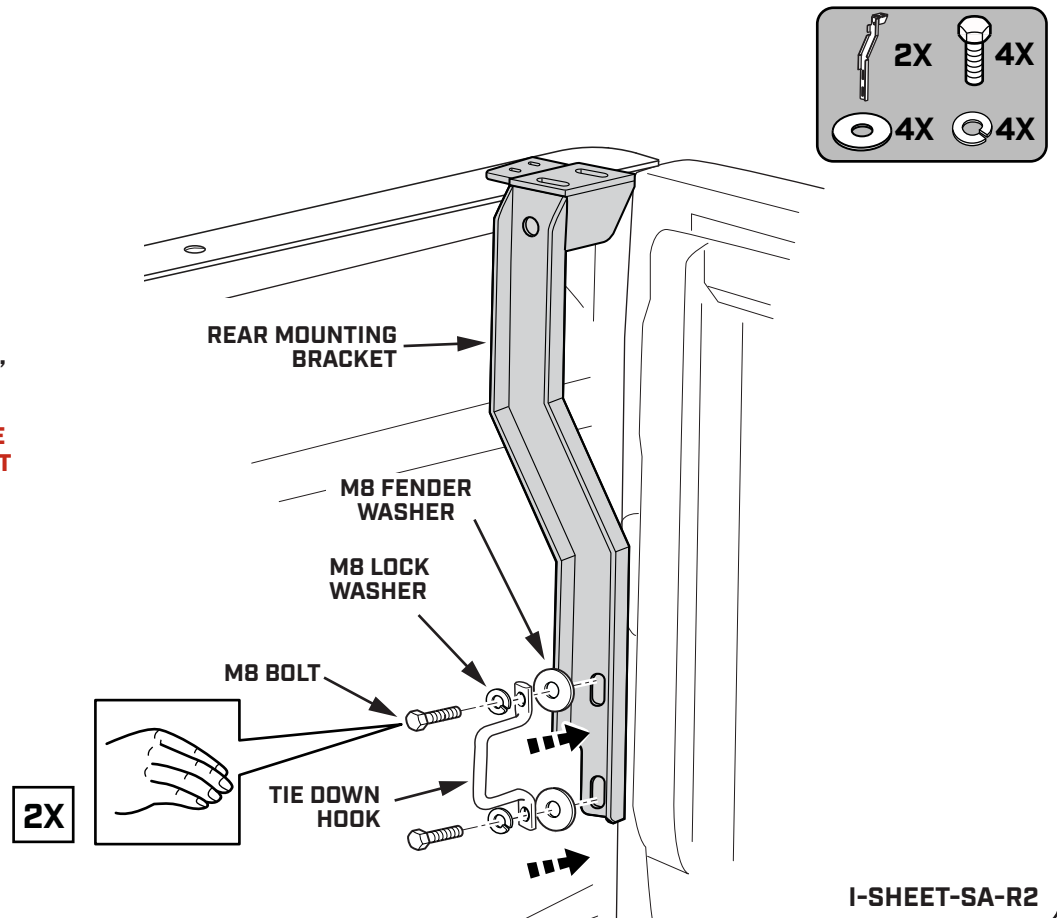

I-SHEET-SA-R2

STEP 31

USE A 5MM ALLEN KEY TO FASTEN THE REAR RIGHT MOUNTING BRACKET TO THE TOP OF THE TRUCK BED.

SECURE THE BRACKET WITH THE FASTENERS AS INDICATED.

REPEAT ON THE OPPOSITE SIDE OF THE VEHICLE WITH THE LEFT FRONT MOUNTING BRACKET.

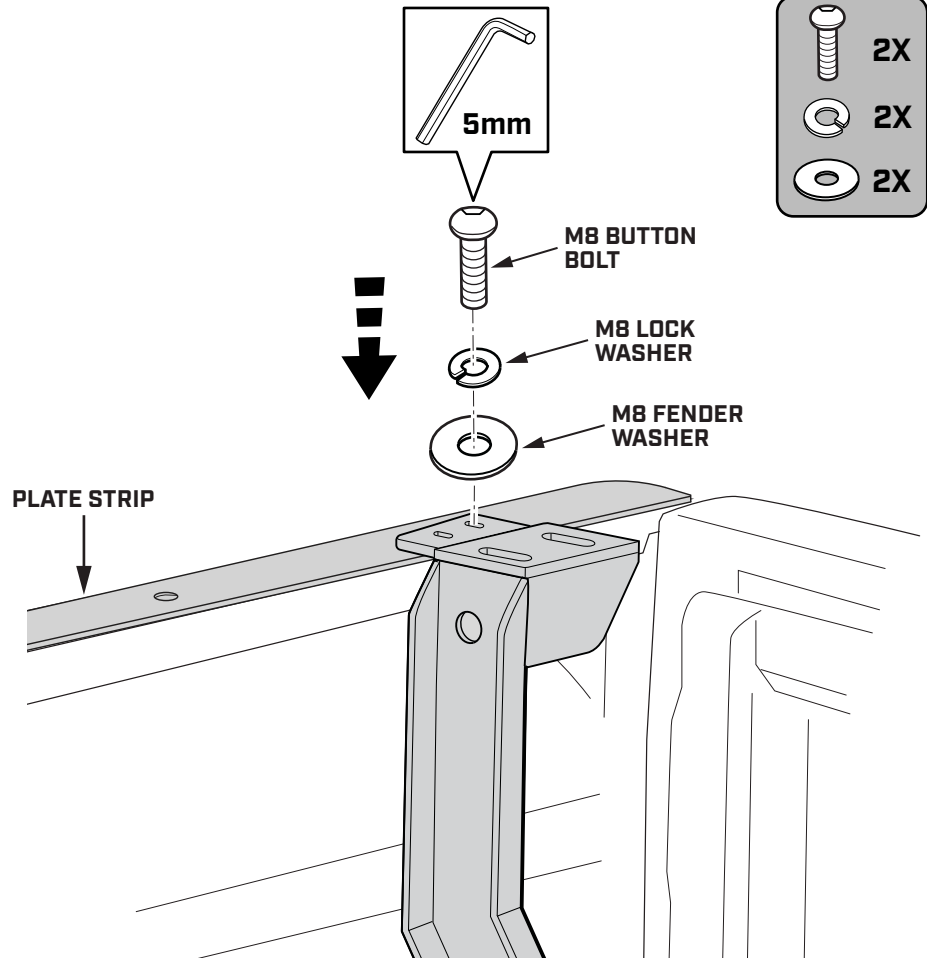

STEP 32

REMOVE THE ADHESIVE BACKING FROM LOAD SPREADER

APPLY LOAD SPREADERS TO THE TOP OF PLATE STRIP. USE THE SLOTS TO ALIGN

REPEAT ON THE OPPOSITE SIDE OF THE VEHICLE.

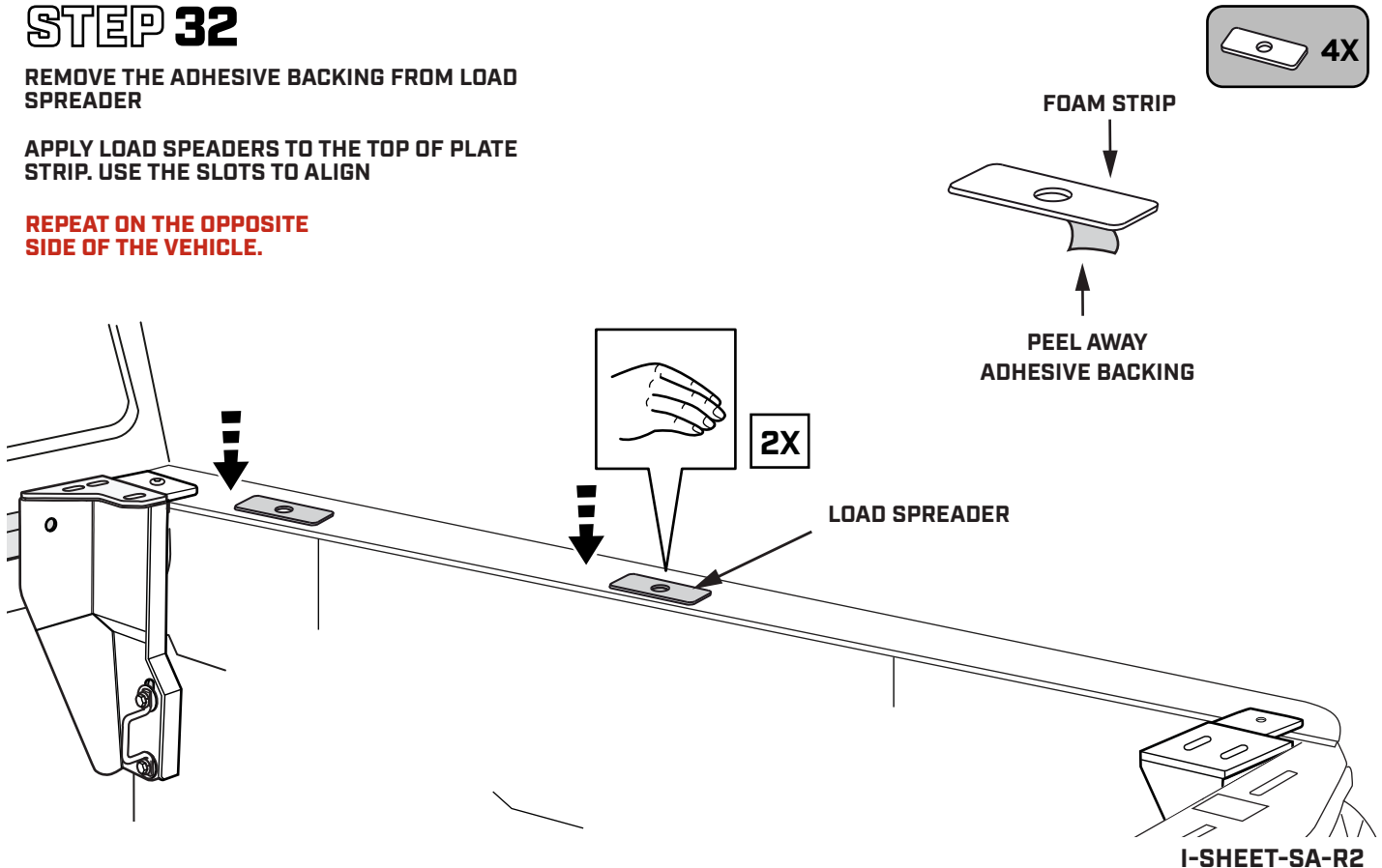

STEP 33

USE 4 PEOPLE TO LIFT THE ASSEMBLED SMARTCAP ONTO THE TRUCK BED.

TO AVOID DAMAGE TO THE D-RUBBER, DO NOT SLIDE THE SMARTCAP INTO PLACE.

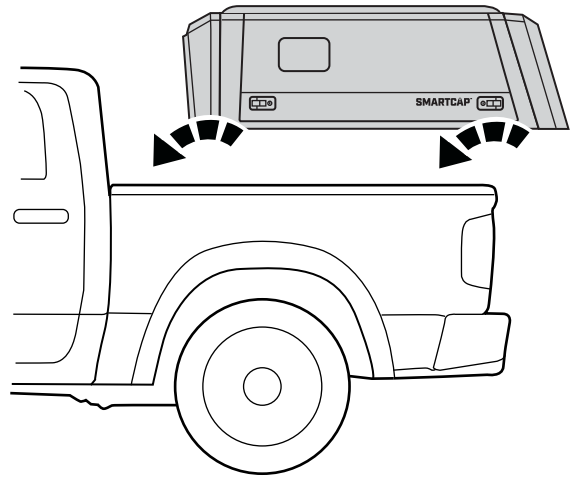

STEP 34

CHECK THAT THE SMARTCAP IS PROPERLY POSITIONED AND CENTERED ON THE TRUCK BED.

IT'S IMPORTANT THAT THE SMARTCAP IS NOT PUSHED TOO FAR FORWARD, LEAVING A GAP BETWEEN THE SMARTCAP AND THE CAB.

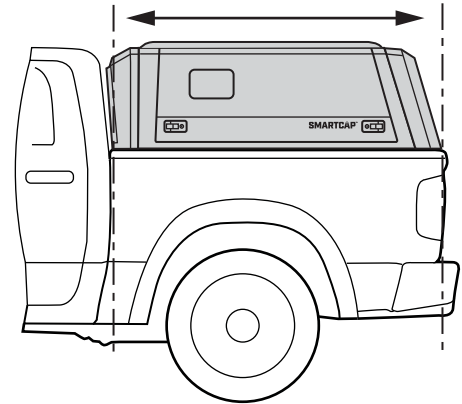
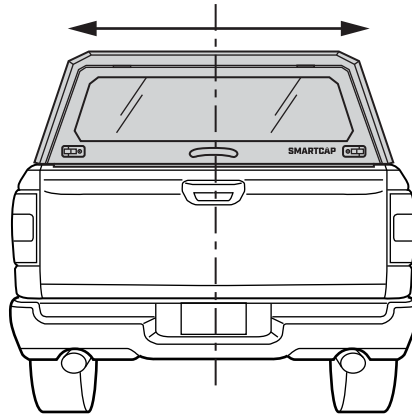

STEP 35

WALK AROUND THE TRUCK BED TO MAKE SURE THE D-RUBBER FITMENT IS CORRECT AND THAT THE RUBBER LIP IS FLUSH WITH THE EXTERIOR OF THE TRUCK BED.

CORRECT D-RUBBER ORIENTATION

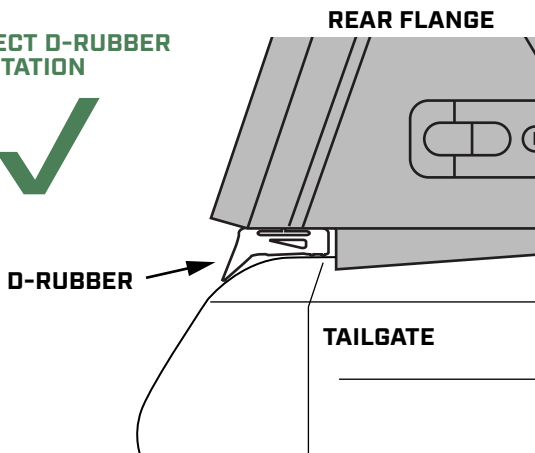

INCORRECT D-RUBBER ORIENTATION

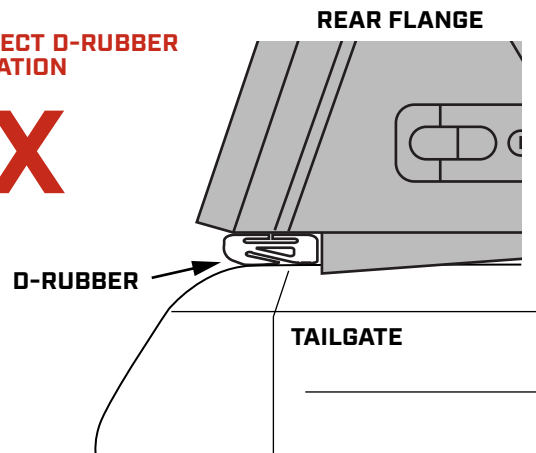

I-SHEET-SA-R2

STEP 36

WITH A 5MM ALLEN KEY, LOOSELY TIGHTEN THE SMARTCAP RIGHT SIDE PANEL TO THE TOP OF THE TRUCK BED USING M8 BUTTON HEAD BOLT, M8 LOCK WASHER, AND M8 FENDER WASHER AS SHOWN BELOW.

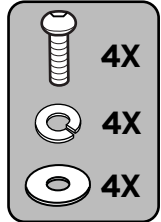

REPEAT ON THE OPPOSITE SIDE OF THE VEHICLE.

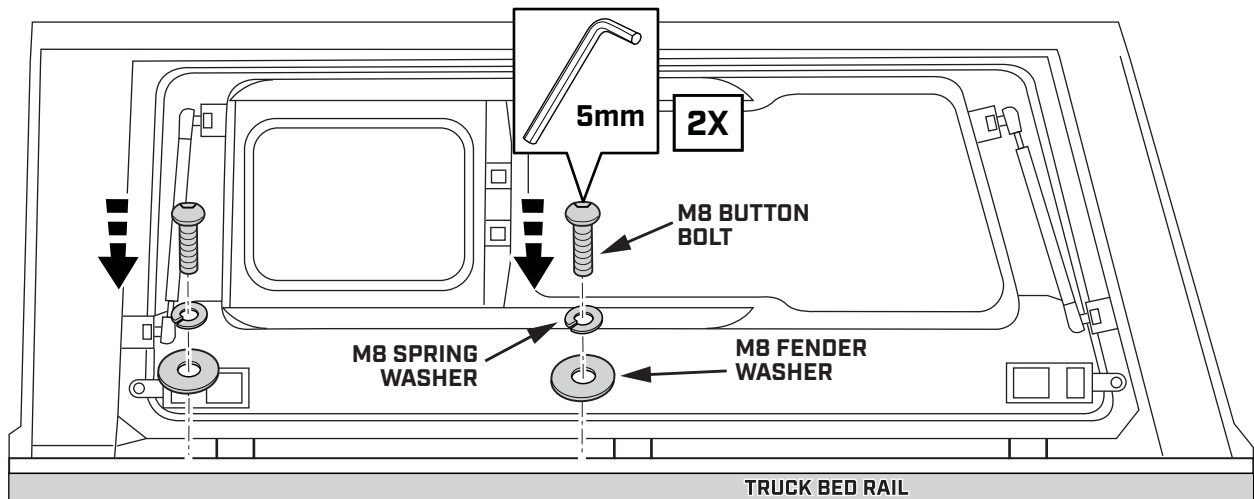

STEP 37

SECURE THE SMARTCAP TO THE RIGHT FRONT MOUNTING BRACKET WITH THE FASTENERS AS INDICATED, HAND TIGHTEN ONLY.

REPEAT ON THE OPPOSITE SIDE OF THE VEHICLE WITH THE LEFT FRONT MOUNTING BRACKET.

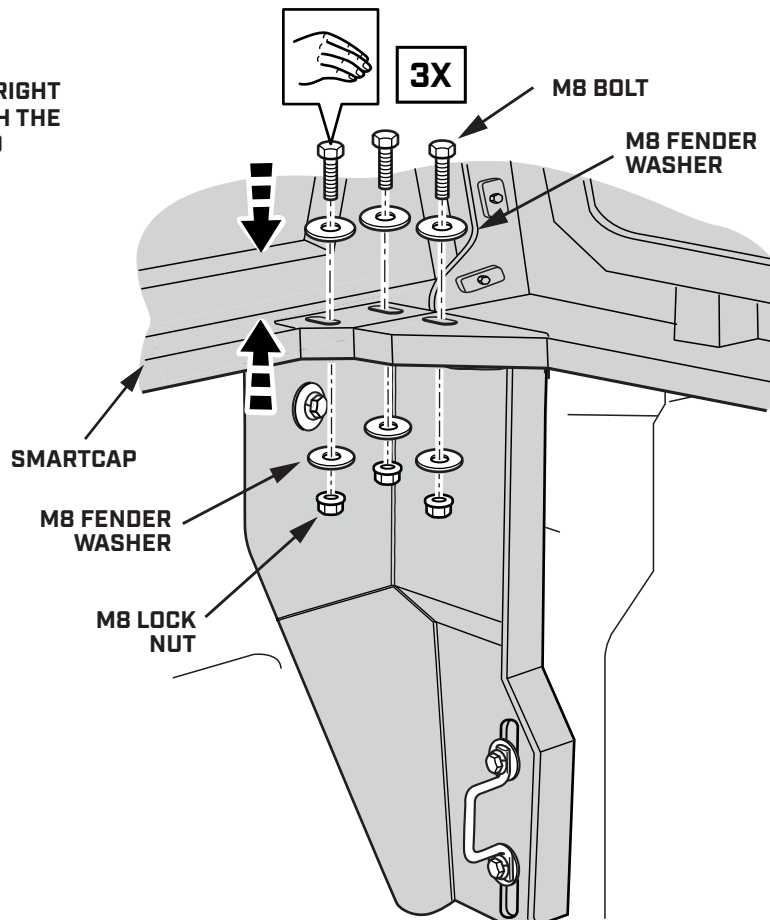
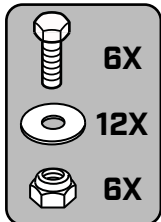

STEP 38

SECURE THE SMARTCAP TO THE RIGHT REAR MOUNTING BRACKET WITH THE FASTENERS AS INDICATED, HAND TIGHTEN ONLY.

REPEAT ON THE OPPOSITE SIDE OF THE VEHICLE WITH THE LEFT REAR MOUNTING BRACKET.

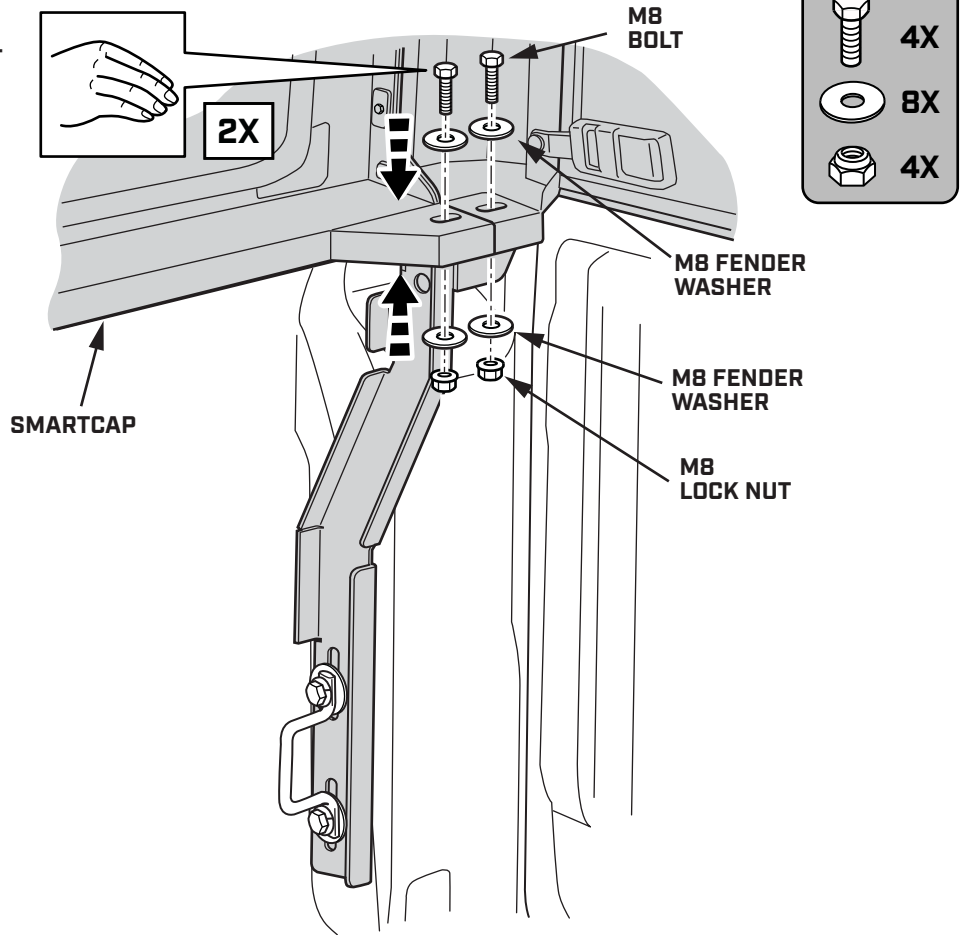

STEP 39

ONCE ALL THE FASTENERS ARE INSTALLED, PARTIALLY TIGHTEN WITH 13MM SOCKET WRENCH AS INDICATED.

PARTIALLY TIGHTEN FASTENERS ON ALL FOUR CORNERS OF THE VEHICLE.

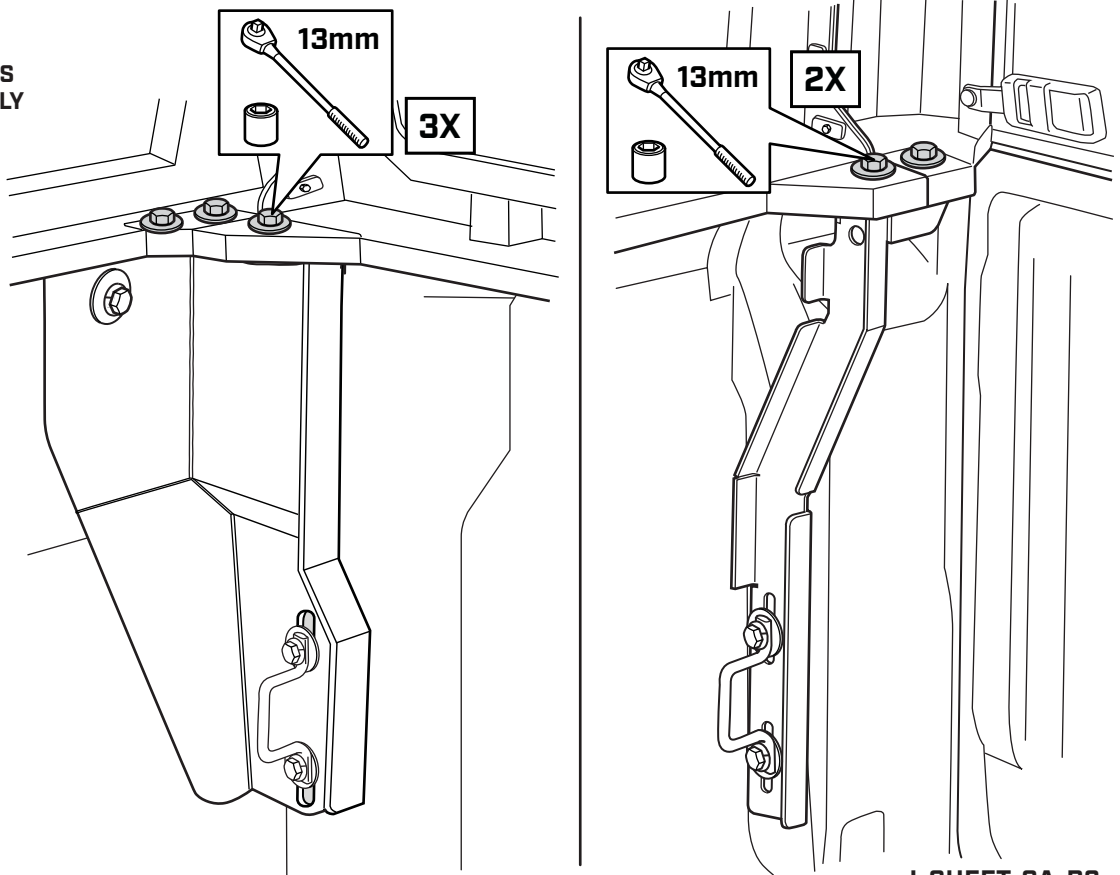

I-SHEET-SA-R2

STEP 40

PRESS DOWN ON THE SMARTCAP TO ACHIEVE 2MM - 3MM COMPRESSION ON THE D-RUBBER AND CONTINUE TIGHTENING BRACKET FASTENERS WITH SOCKET WRENCH AS INDICATED.

CONTINUE TIGHTENING FASTENERS ON ALL FOUR CORNERS OF THE VEHICLE.

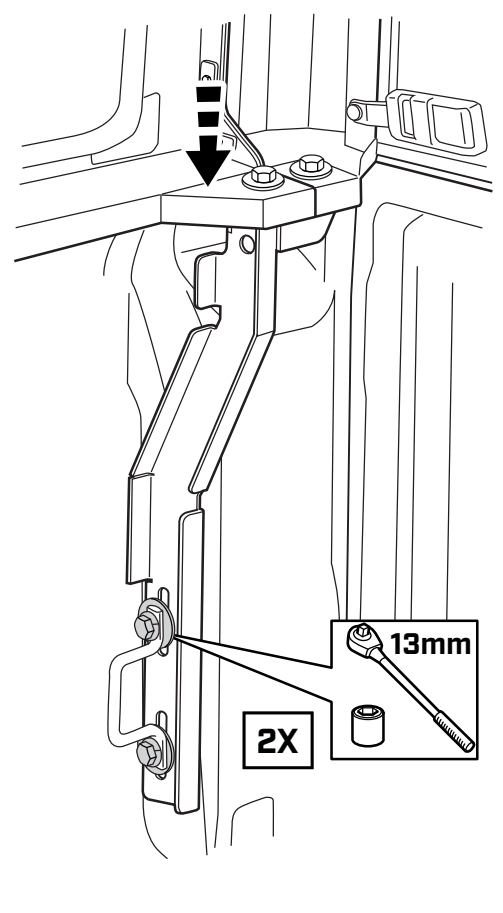
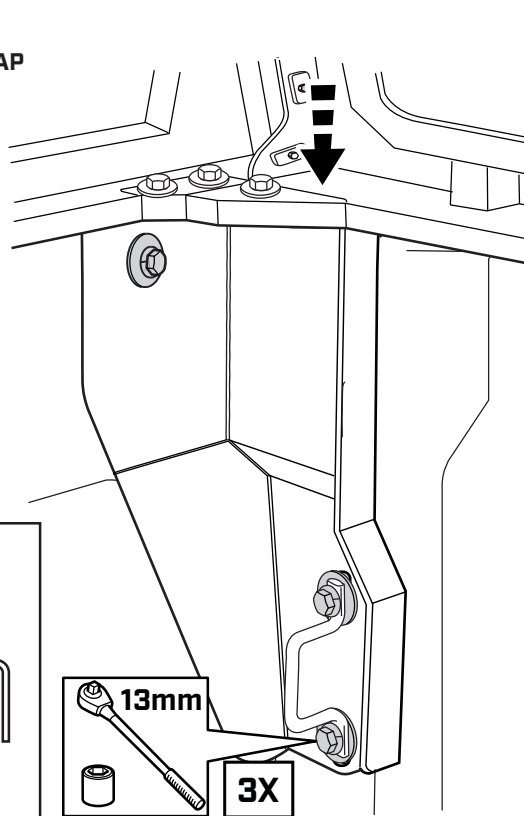
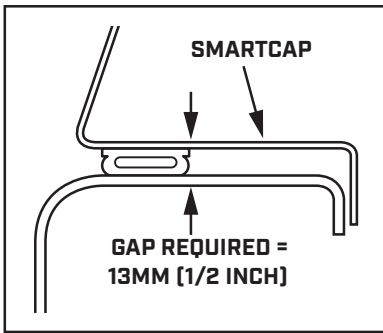

STEP 41

ONCE SMARTCAP IS POSITIONED CORRECTLY, FULLY TIGHTEN UPPER FASTENERS USING A TORQUE WRENCH AND 13MM SOCKET TO 4.4 FT. LBS (6 NEWTON METERS)

FULLY TIGHTEN UPPER FASTENERS ON ALL FOUR CORNERS OF THE VEHICLE.

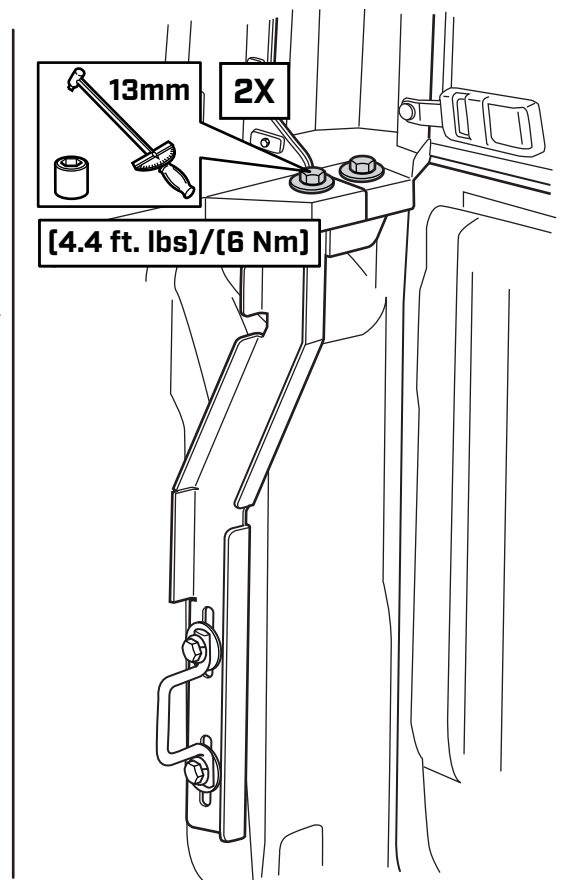
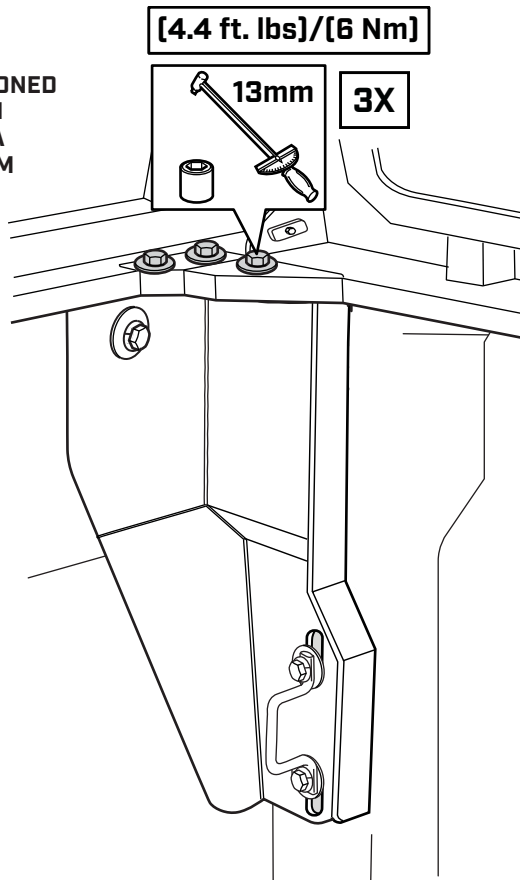

STEP 42

ONCE SMARTCAP IS POSITIONED CORRECTLY, FULLY TIGHTEN LOWER FASTENERS USING A TORQUE WRENCH AND 13MM SOCKET TO 9 FT. LBS [12.2 NEWTON METERS]

FULLY TIGHTEN LOWER FASTENERS ON ALL FOUR CORNERS OF THE VEHICLE.

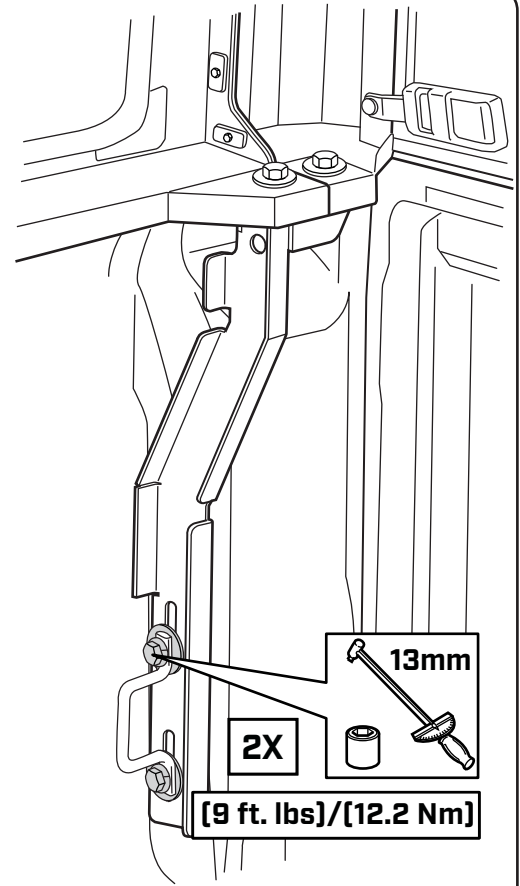
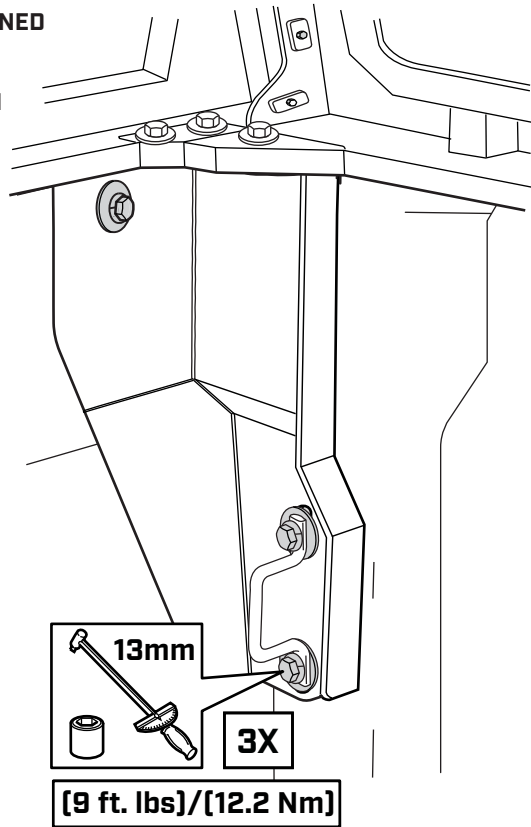

STEP 43

FULLY TIGHTEN THE M8 BUTTON HEAD BOLTS ALONG THE SIDE RAIL ATTACHMENT POINTS OF THE CAP USING A TORQUE WRENCH AND A 5MM HEX KEY BIT TO 4.4 FT. LBS. [6 NEWTON METERS].

REPEAT ON THE OPPOSITE SIDE OF THE VEHICLE.

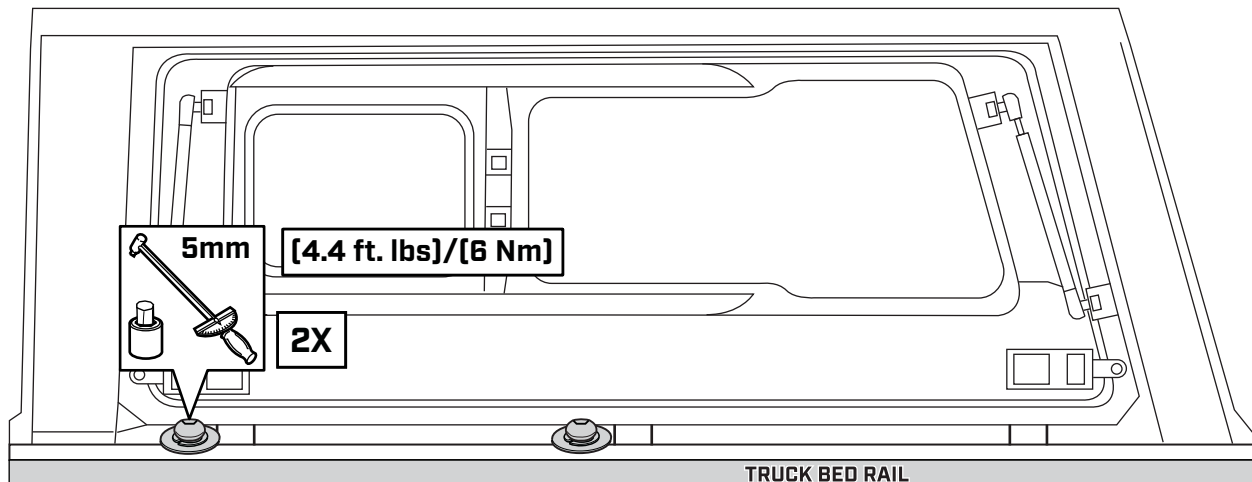

I-SHEET-SA-R2

SMARTCAP[®]

**THANKS FOR YOUR PURCHASE.
PLEASE LET US KNOW IF YOU HAVE ANY QUESTIONS.**

SMARTCAP.COM
SUPPORT.SA@SMARTCAP.COM - REST OF WORLD
SUPPORT.NA@SMARTCAP.COM - NORTH AMERICA/CANADA

