

SMARTCAP®

INSTRUCTION GUIDE EVO, EVOa & EVOc SERIES

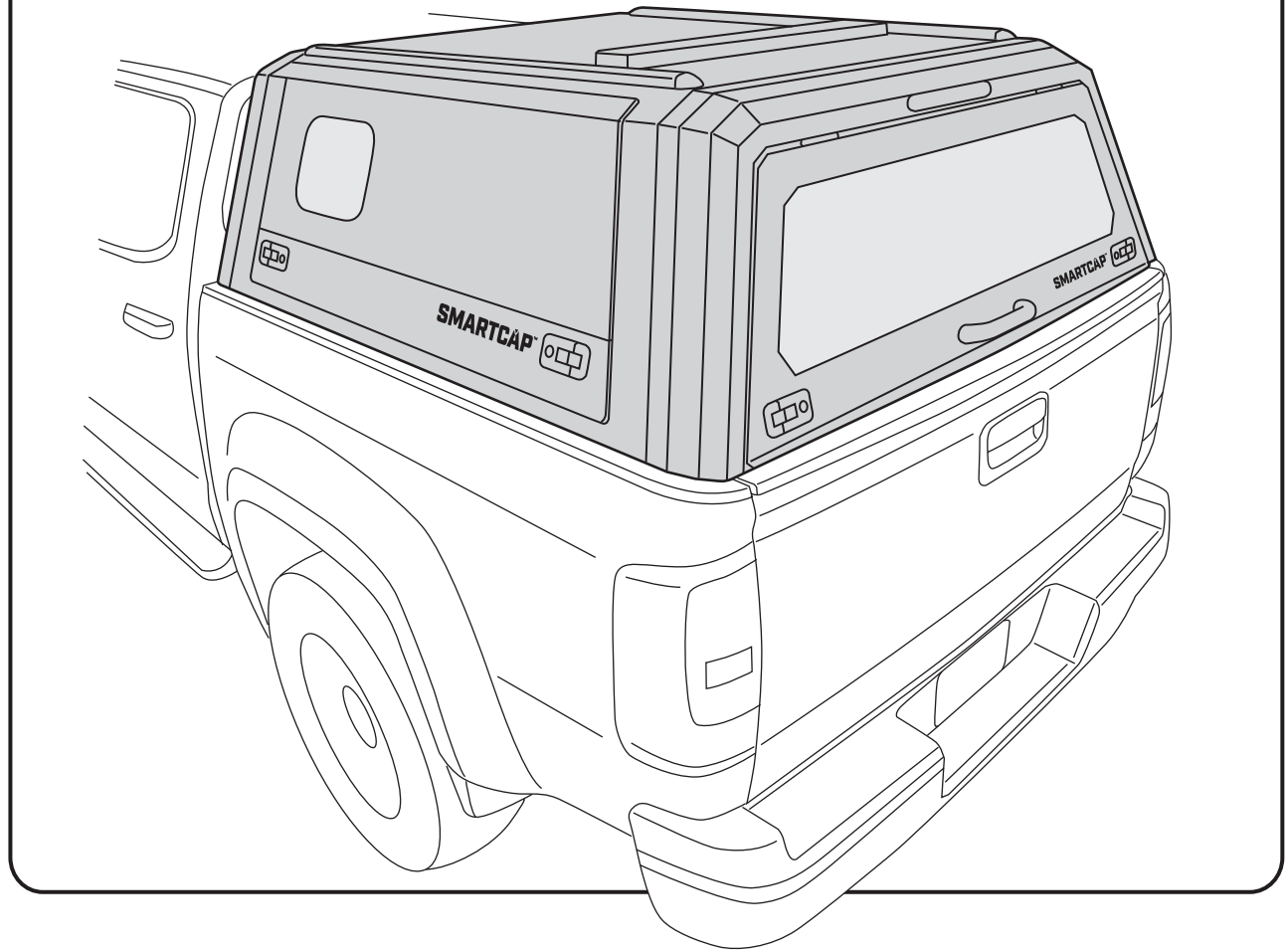

- ▼ **PREPARE A CLEAN WORK AREA.**
- ▼ **WE RECOMMEND A MINIMUM OF 2 PEOPLE FOR ASSEMBLY.**
- ▼ **ENSURE THE REQUIRED TOOLS ARE PRESENT AND ALL HARDWARE CONTENTS ARE ACCOUNTED FOR.**
- ▼ **NEVER USE ACETONE OR THINNERS ON PAINTED PARTS.**
- ▼ **READ THROUGH THE ENTIRE INSTRUCTION GUIDE BEFORE STARTING THIS PROCEDURE AND FOLLOW THE STEPS CAREFULLY TO AVOID ANY DAMAGE TO THE COMPONENTS OR THE VEHICLE.**

SMARTCAP.COM

SUPPORT.NA@SMARTCAP.COM - NORTH AMERICA

SUPPORT.SA@SMARTCAP.COM - REST OF WORLD



I-SHEET-ROW-U3

TOOLS REQUIRED

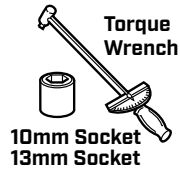
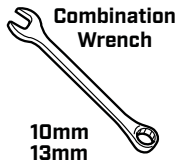
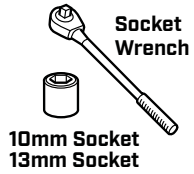

LAND CRUISER ONLY



IMPORTANT

- ▼ USE ONLY THE TOOLS RECOMMENDED ABOVE.
- ▼ USE ONLY THE HARDWARE PROVIDED IN THIS KIT.
- ▼ ASSISTANCE WILL BE NEEDED FOR THIS INSTALLATION. FOUR PEOPLE ARE RECOMMENDED TO LIFT THE SMARTCAP ONTO THE VEHICLE.
- ▼ AVOID PINCHING OR CRUSHING HANDS AND FINGERS.
- ▼ INSPECT ALL KIT COMPONENTS FOR DAMAGE BEFORE ASSEMBLY.
- ▼ NEVER USE ACETONE OR THINNERS ON PAINTED PARTS.

COMPONENTS

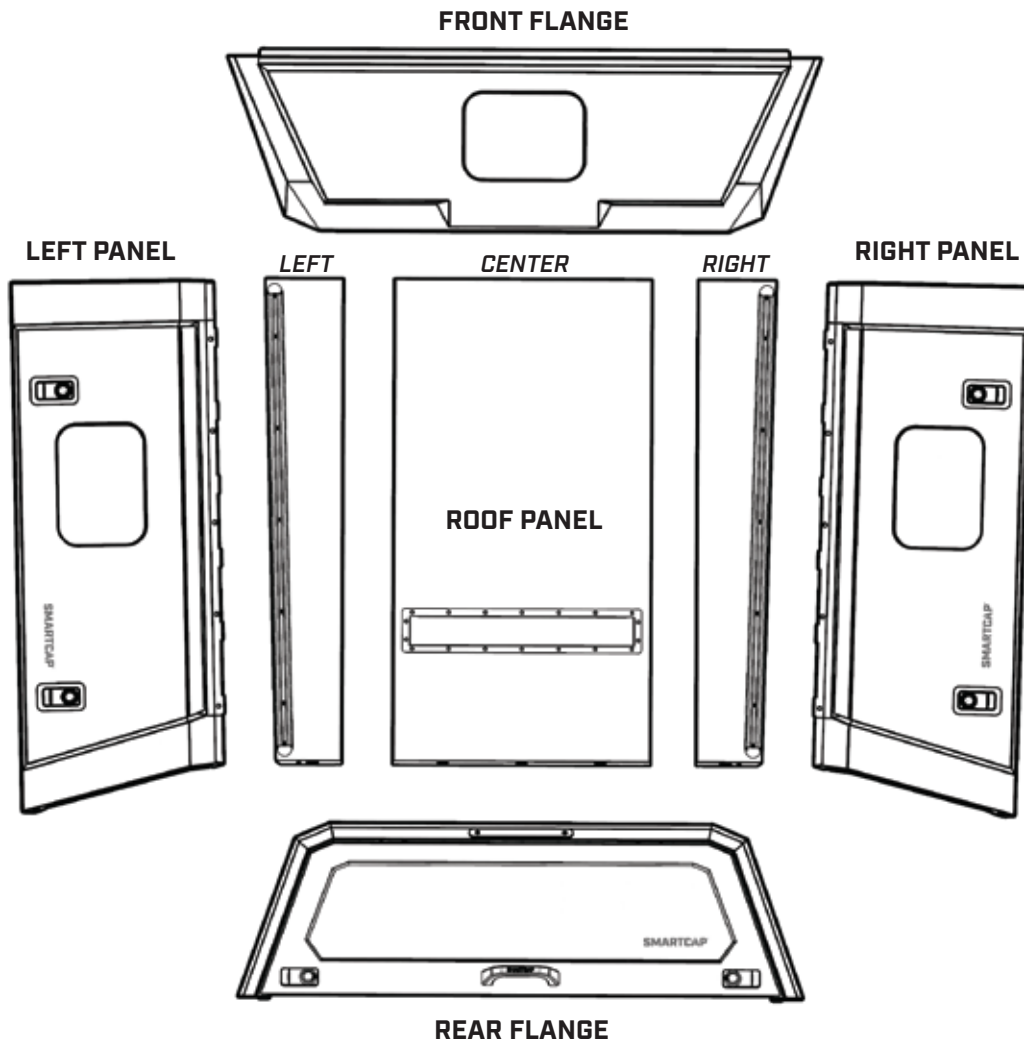

I-SHEET-ROW-U3

ASSEMBLY HARDWARE

FITMENT KIT

M6 BOLT

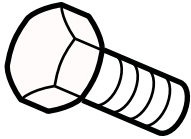

42X

**FASTENER
BLOCK CLAMP**

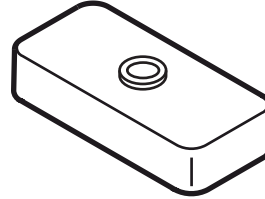

42X

**M6 LOCK
WASHER**



42X

**FASTENER
BLOCK**

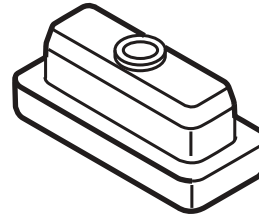

42X

D - RUBBER



1X

SPARE PARTS

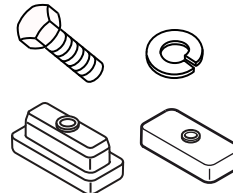

2X

PRE-FASTENED TO ROOF PANEL

**M6 FENDER
WASHER**



12X

SHORT BED

14X

STANDARD BED

**M6 LOCK
NUT**



12X

SHORT BED

14X

STANDARD BED

STEP 1



IMPORTANT

- ▼ BE SURE TO REMOVE ALL SEVEN PANELS FROM THEIR PACKAGING AND INSPECT THE PAINTED SURFACES PRIOR TO ASSEMBLY, AS SMARTCAP WILL NOT ACCEPT WARRANTY CLAIMS AFTER ASSEMBLY IS COMPLETED. IF MANUFACTURING IMPERFECTIONS OR SHIPPING DAMAGES ARE FOUND, DO NOT CONTINUE WITH THE ASSEMBLY PROCESS AND CONTACT SUPPORT.SA@SMARTCAP.COM.

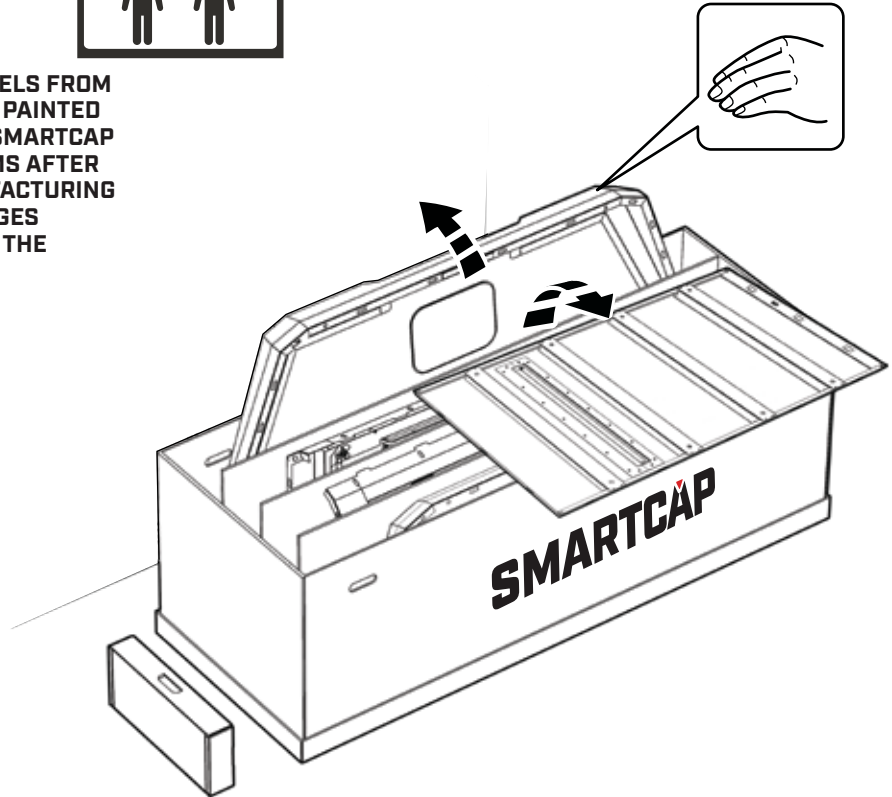

STEP 2

REMOVE THE FOUR CORNER STIFFENERS AND ONE OF THE CARDBOARD DIVIDERS TO BE USED AS A PROTECTIVE SURFACE DURING ASSEMBLY.

UNFOLD THE CARDBOARD DIVIDER AND PLACE IT WHERE YOU PLAN TO ASSEMBLE YOUR CAP.

PLACE THE FOUR CORNER STIFFENERS AS SHOWN BELOW.

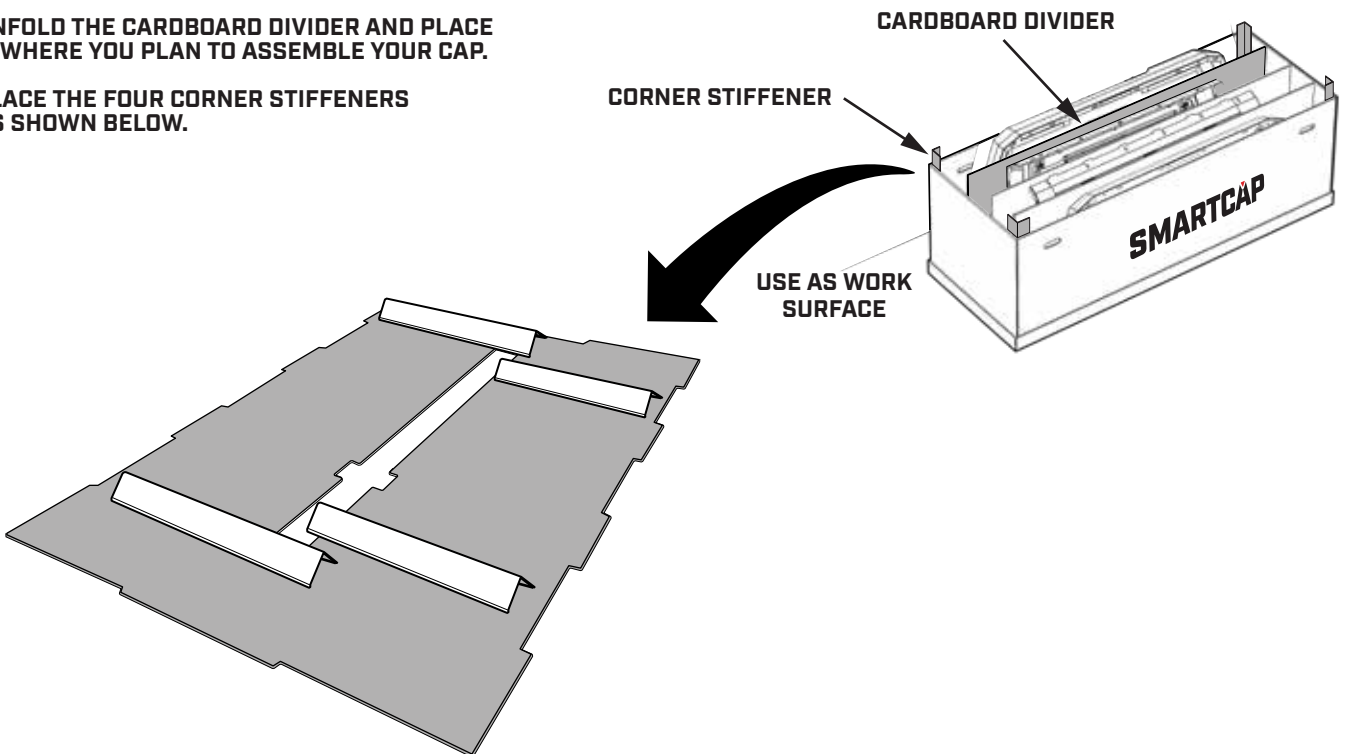

I-SHEET-ROW-U3

STEP 3

PLACE THE ROOF PANELS ON TOP OF THE CORNER STIFFENERS, WITH THE BOTTOM OF THE ROOF PANELS FACING UP.

ALIGN THE PANELS SO THAT THE PROFILE OF THE FRONT AND REAR EDGES MATCH.

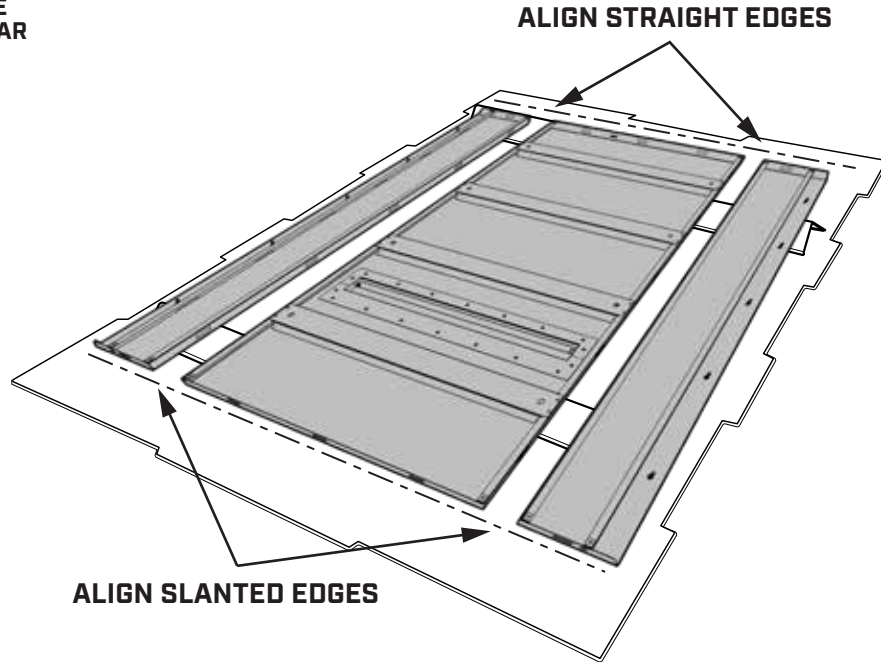

STEP 4

ASSEMBLE THE FASTENER BLOCKS TO THE ROOF PANELS USING A TORQUE WRENCH AND 10MM SOCKET TO 3.7 FT. LBS [5 NEWTON METERS].

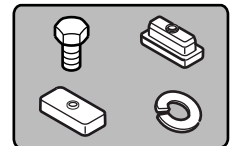

MAKE SURE ROOF PANELS ARE LEVEL

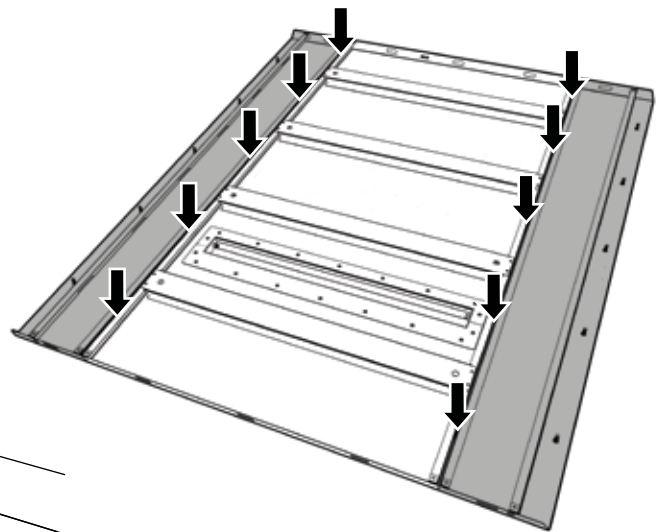

- 12X SHORT BED
- 14X STANDARD BED



M6 BOLT

BLOCK CLAMP

M6 LOCK WASHER

FASTENER BLOCK

[3.7 ft. lbs]/[5 Nm]

I-SHEET-ROW-U3

STEP 5

USE A 10MM COMBINATION WRENCH TO REMOVE THE LOCK NUTS AND FENDER WASHERS FROM THE ROOF BOLTS AND SAVE FOR REUSE.



AIR VENT INDICATES REAR

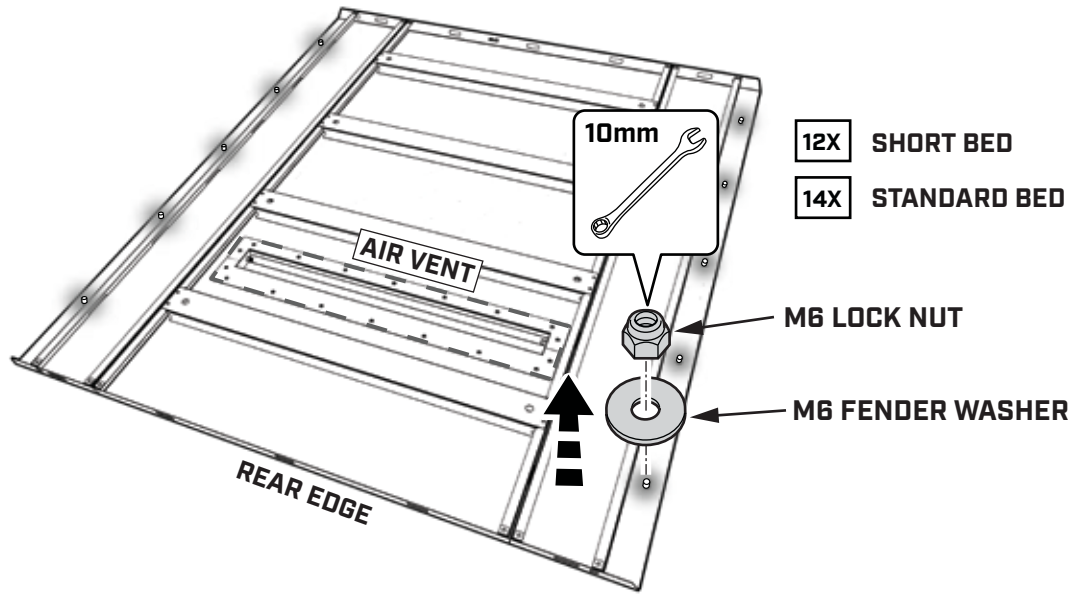

STEP 6

RETRIEVE THE FASTENER BLOCKS FROM THE FITMENT KIT AND PLACE 15 ON EACH SIDE OF THE ROOF PANEL.

TAKE APART THE FASTENER BLOCKS SO THEY ARE READY TO USE DURING ASSEMBLY.

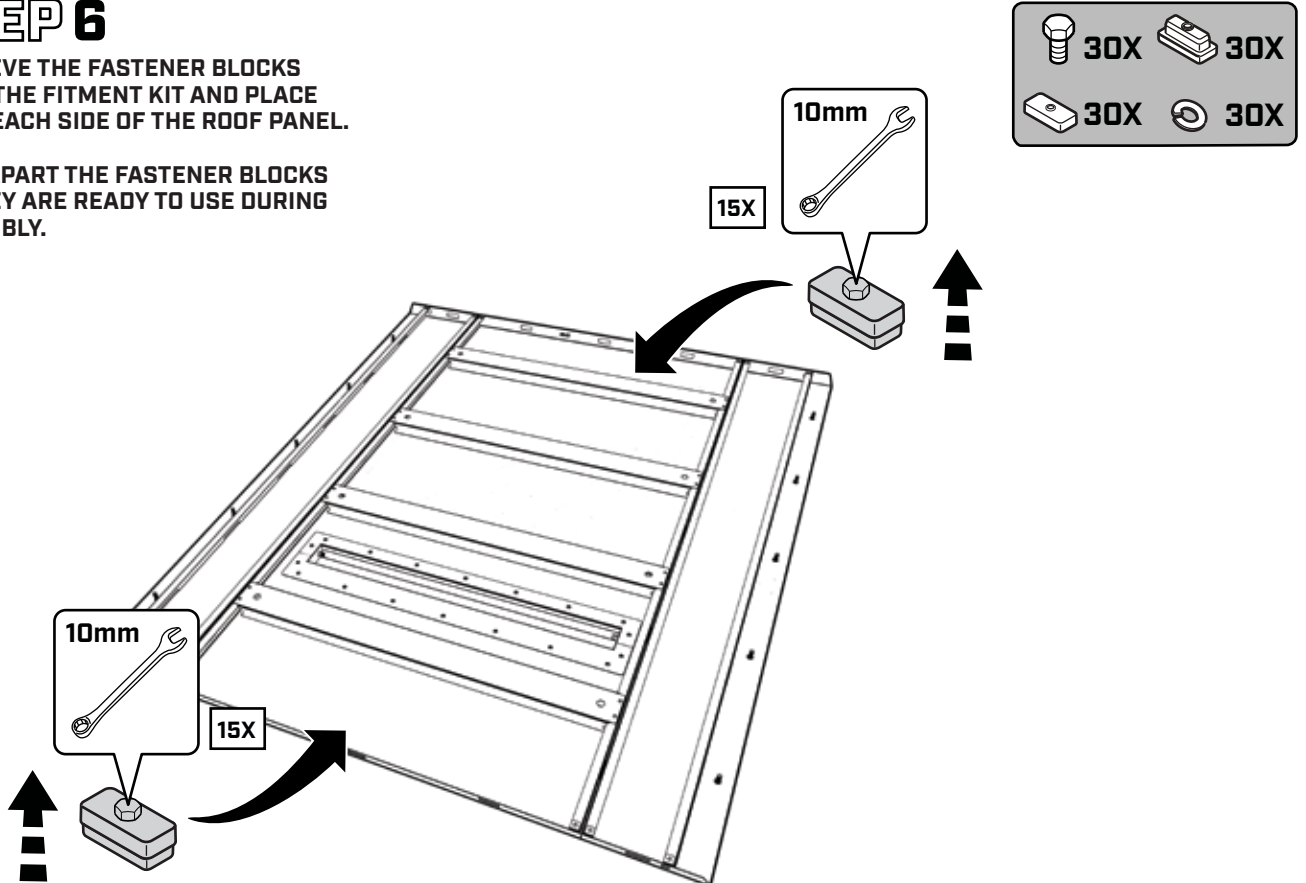

I-SHEET-ROW-U3

STEP 7

LOCATE THE RIGHT PANEL IN THE SMARTCAP PACKAGE AND BRING IT TO YOUR WORK AREA.

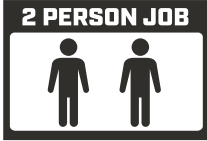

SLANTED EDGE INDICATES REAR

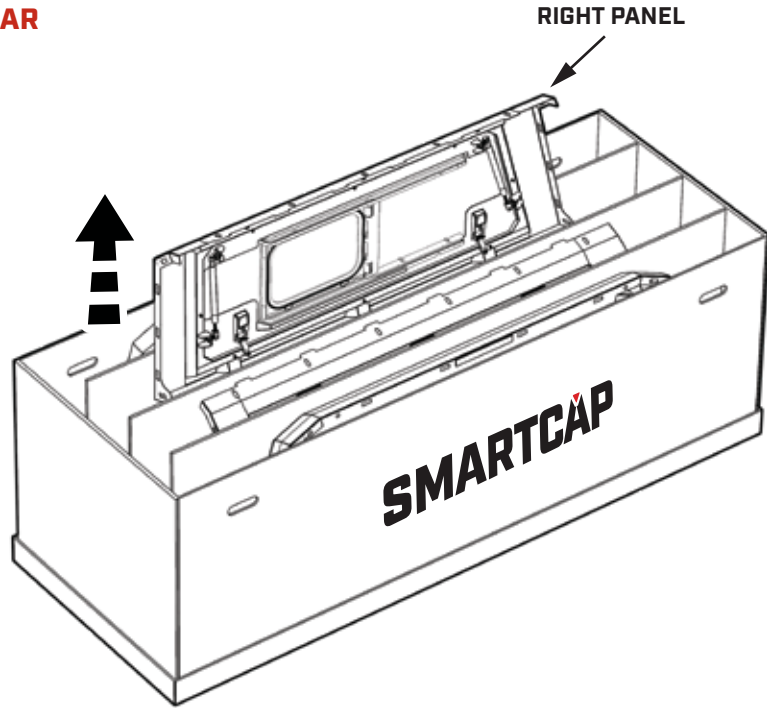

STEP 8

INSERT PANEL TABS INTO THE NARROW SLOTS JUST ABOVE FOAM PADDING ON ROOF PANEL.

TAP FIRMLY WITH PALM OF HAND UNTIL THERE IS A 2-3MM GAP.

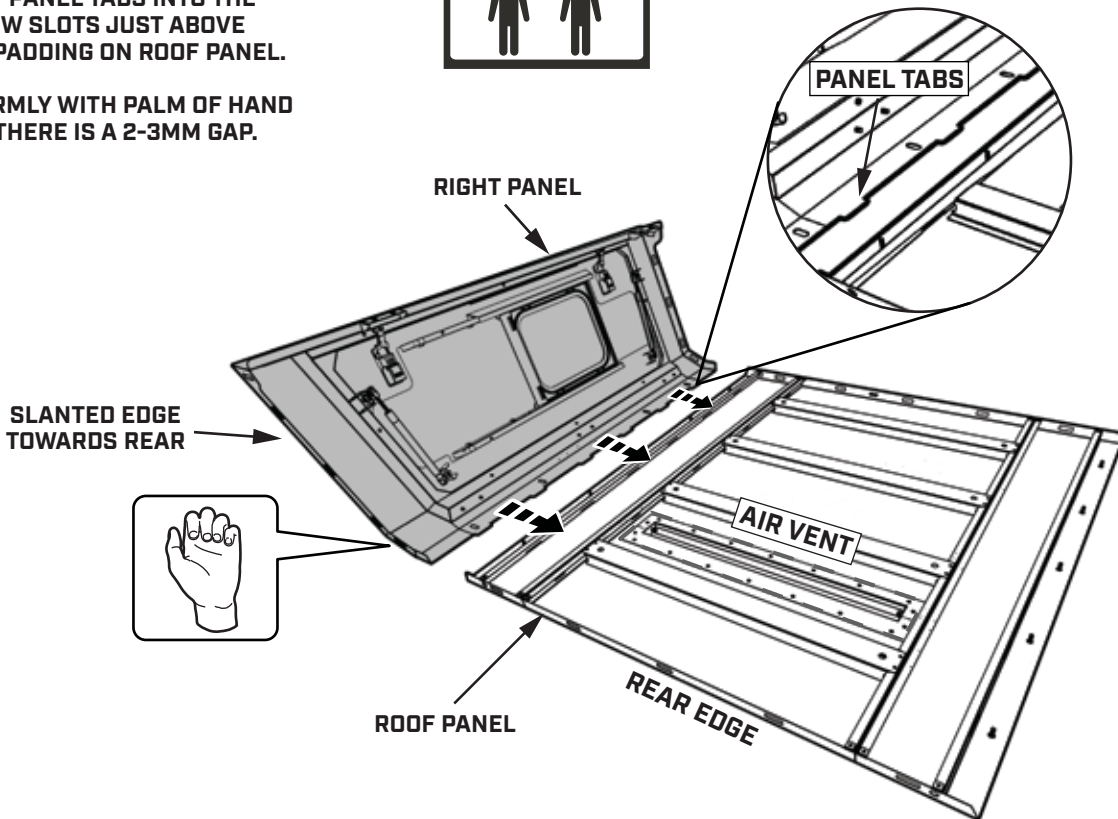

I-SHEET-ROW-U3

STEP 9

HAND TIGHTEN M6 LOCK NUT WITH M6 FENDER WASHER TO ALL BOLTS.

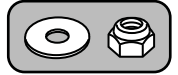

SUPPORT RIGHT PANEL UNTIL ASSEMBLED TO FRONT FLANGE

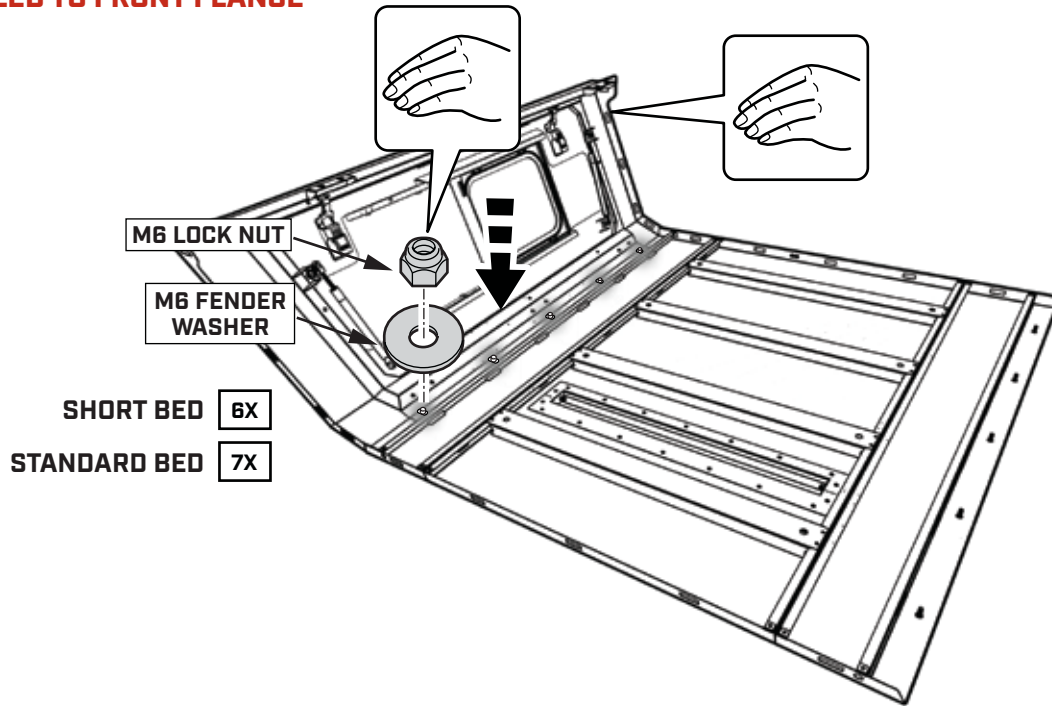

STEP 10

LOCATE THE FRONT FLANGE IN THE SMARTCAP PACKAGE AND BRING IT TO YOUR WORK AREA.

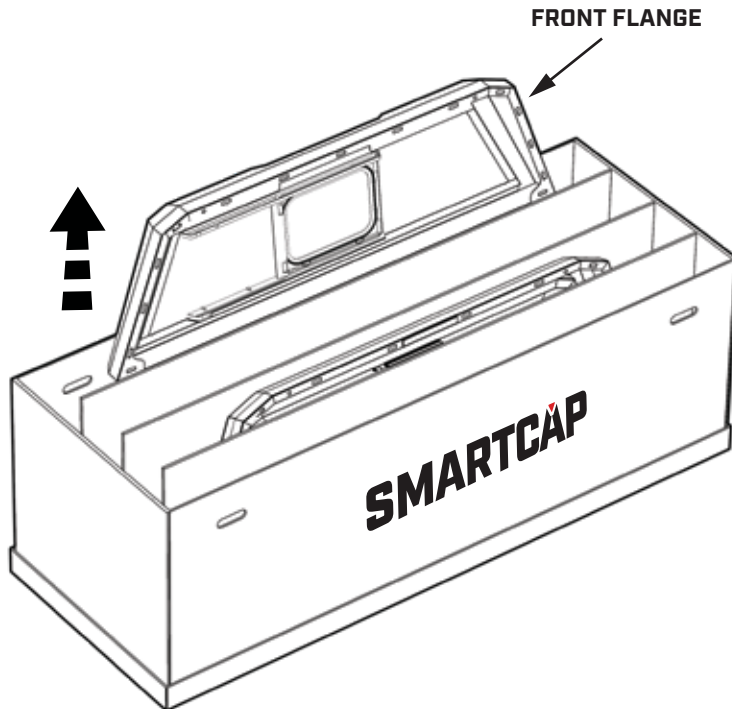

I-SHEET-ROW-U3

STEP 11

PLACE FRONT FLANGE AS SHOWN BELOW.

HAND TIGHTEN TWO FASTENER BLOCKS AT THE INDICATED LOCATIONS TO SUPPORT THE RIGHT PANEL AND FRONT FLANGE.

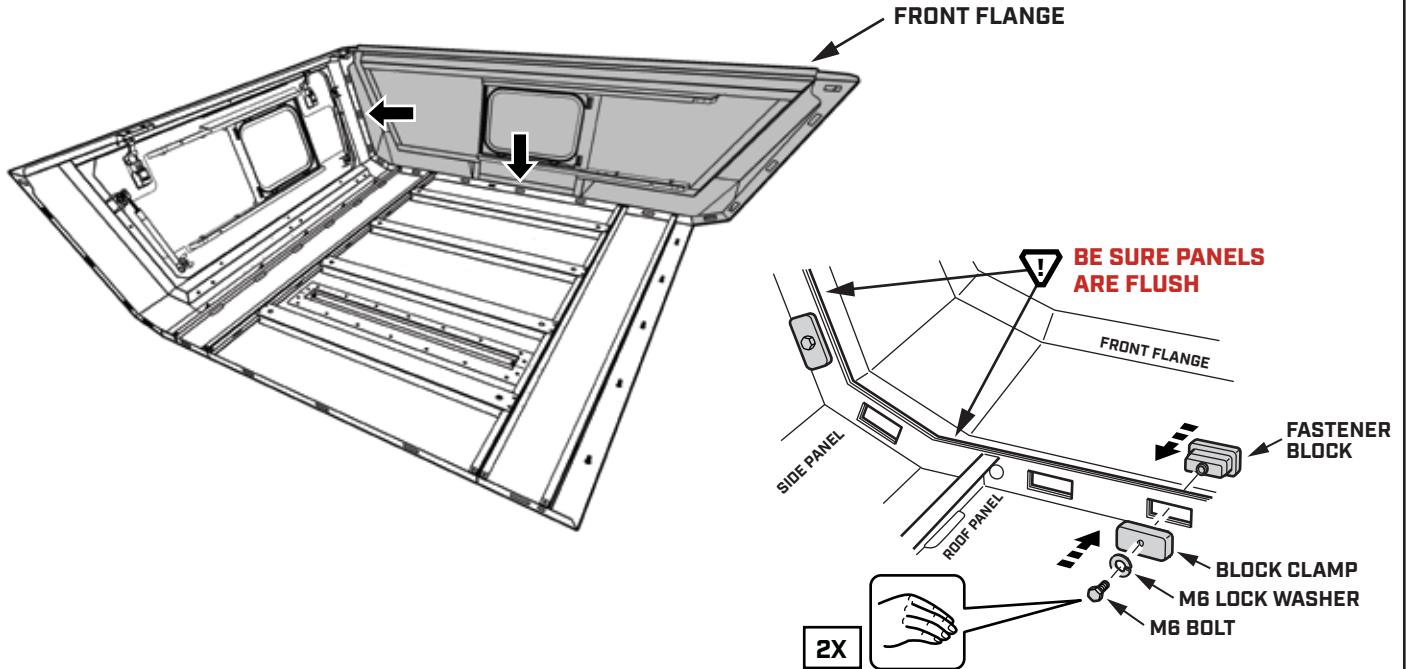

STEP 12

LOCATE THE LEFT PANEL IN THE SMARTCAP PACKAGE AND BRING IT TO YOUR WORK AREA.



SLANTED EDGE INDICATES REAR

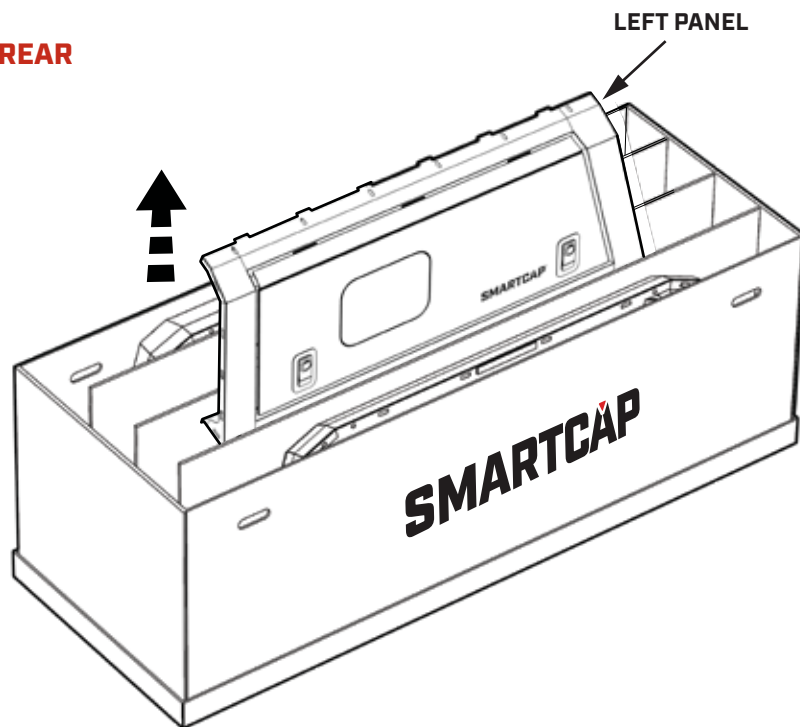

STEP 13

INSERT PANEL TABS INTO THE NARROW SLOTS JUST ABOVE FOAM PADDING ON ROOF PANEL.

TAP FIRMLY WITH PALM OF HAND UNTIL THERE IS A 2-3MM GAP.

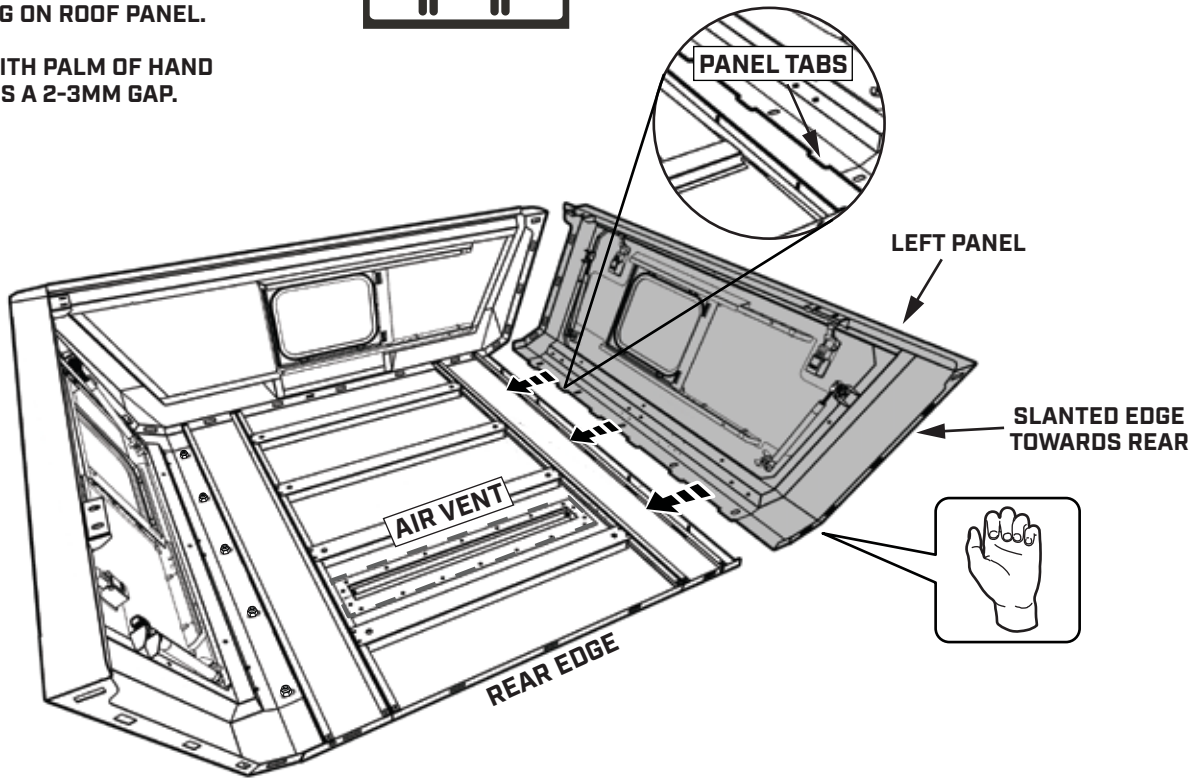

STEP 14

HAND TIGHTEN M6 LOCK NUT WITH M6 FENDER WASHER TO ALL BOLTS.

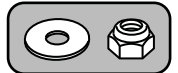

! SUPPORT LEFT PANEL UNTIL ASSEMBLED TO FRONT FLANGE

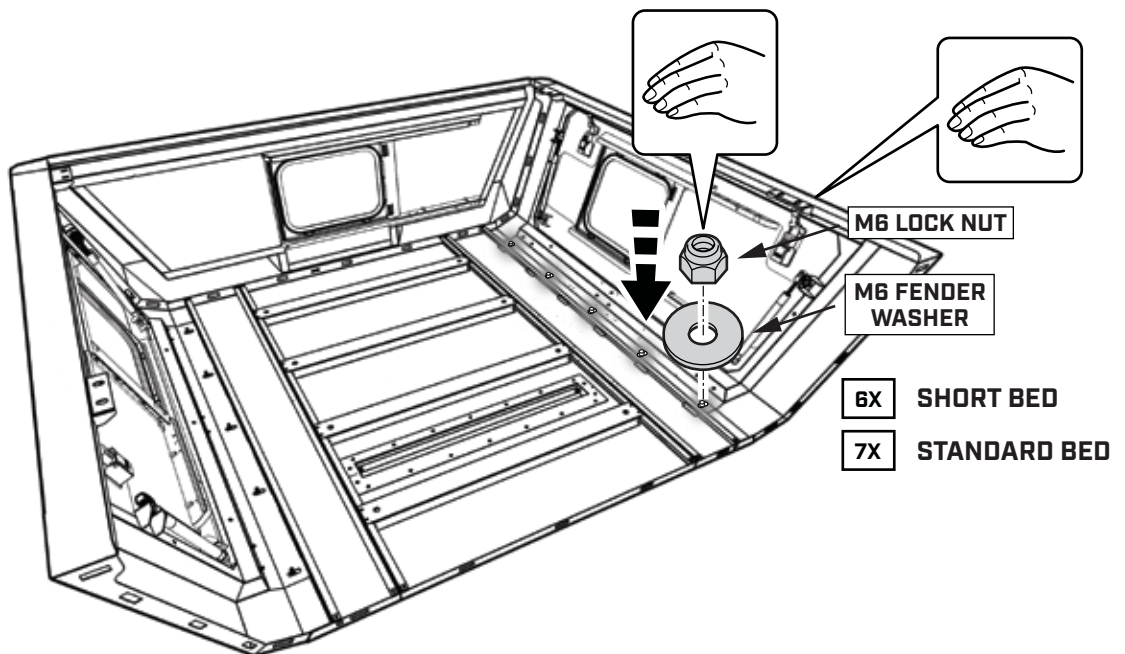

I-SHEET-ROW-U3

STEP 15

INSTALL HARDWARE ALONG FRONT FLANGE WITH BOLT ON INSIDE.

START AT CENTER OF THE FRONT FLANGE AND WORK YOUR WAY OUTWARDS.

ADJUST LEFT AND RIGHT PANELS TO ALIGN THE FASTENER BLOCK HOLES.

HAND TIGHTEN ONLY.

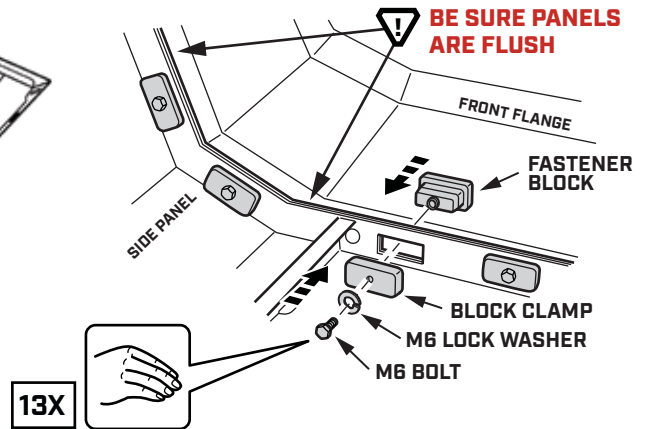
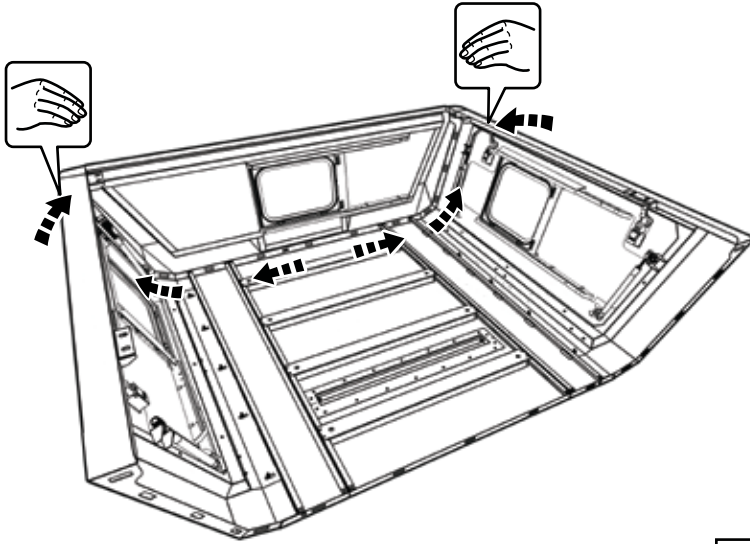

STEP 16

LOCATE THE REAR FLANGE IN THE SMARTCAP PACKAGE AND BRING IT TO YOUR WORK AREA.

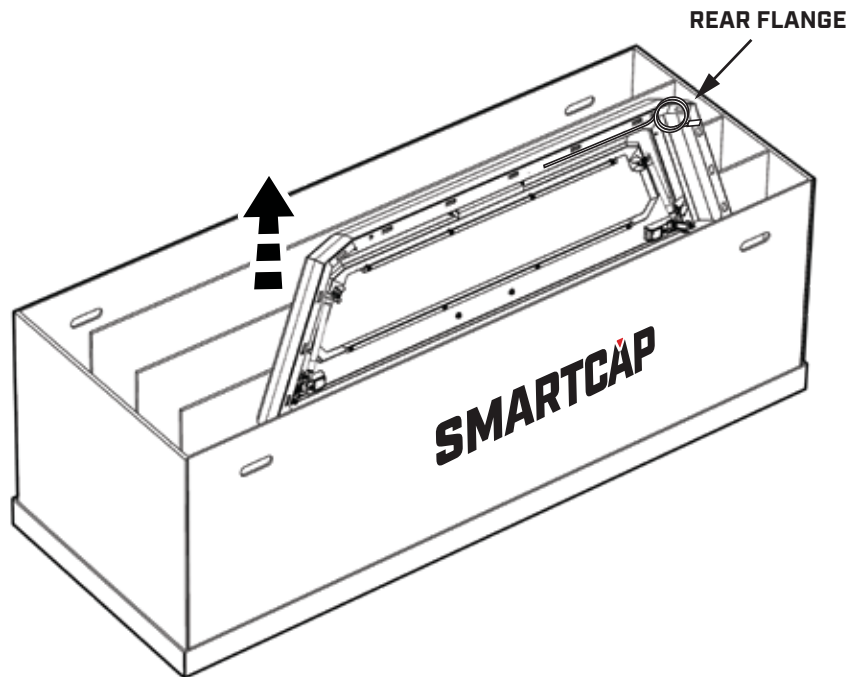

STEP 17

PLACE REAR FLANGE AS SHOWN BELOW.

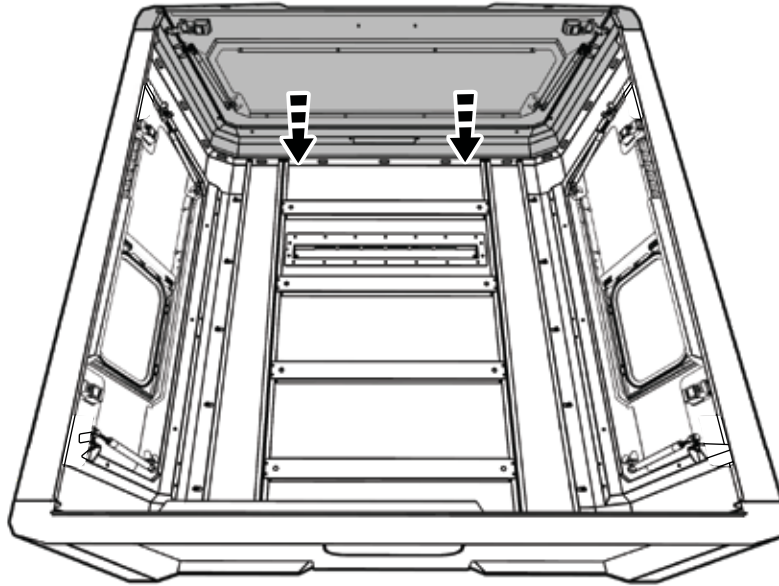

STEP 18

INSTALL HARDWARE ALONG REAR FLANGE WITH BOLT ON INSIDE.



START AT CENTER OF THE REAR FLANGE AND WORK YOUR WAY OUTWARDS.

ADJUST LEFT AND RIGHT PANELS TO ALIGN THE FASTENER BLOCK HOLES.

HAND TIGHTEN ONLY.

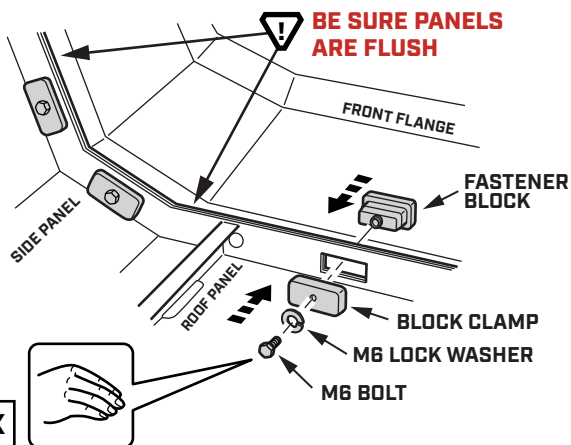

15X

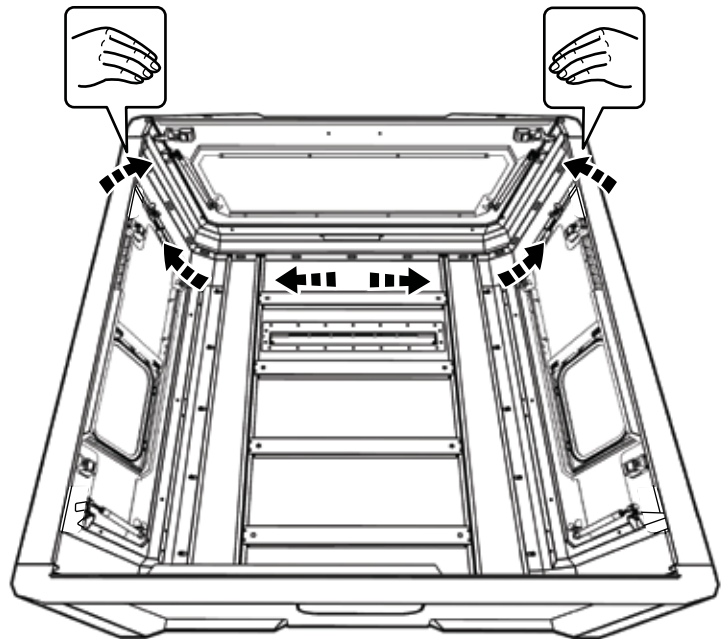

I-SHEET-ROW-U3

STEP 19

TIGHTEN ALL HARDWARE WITH TORQUE WRENCH
AND 10MM SOCKET TO 3.7 FT. LBS. (5 NEWTON METERS)

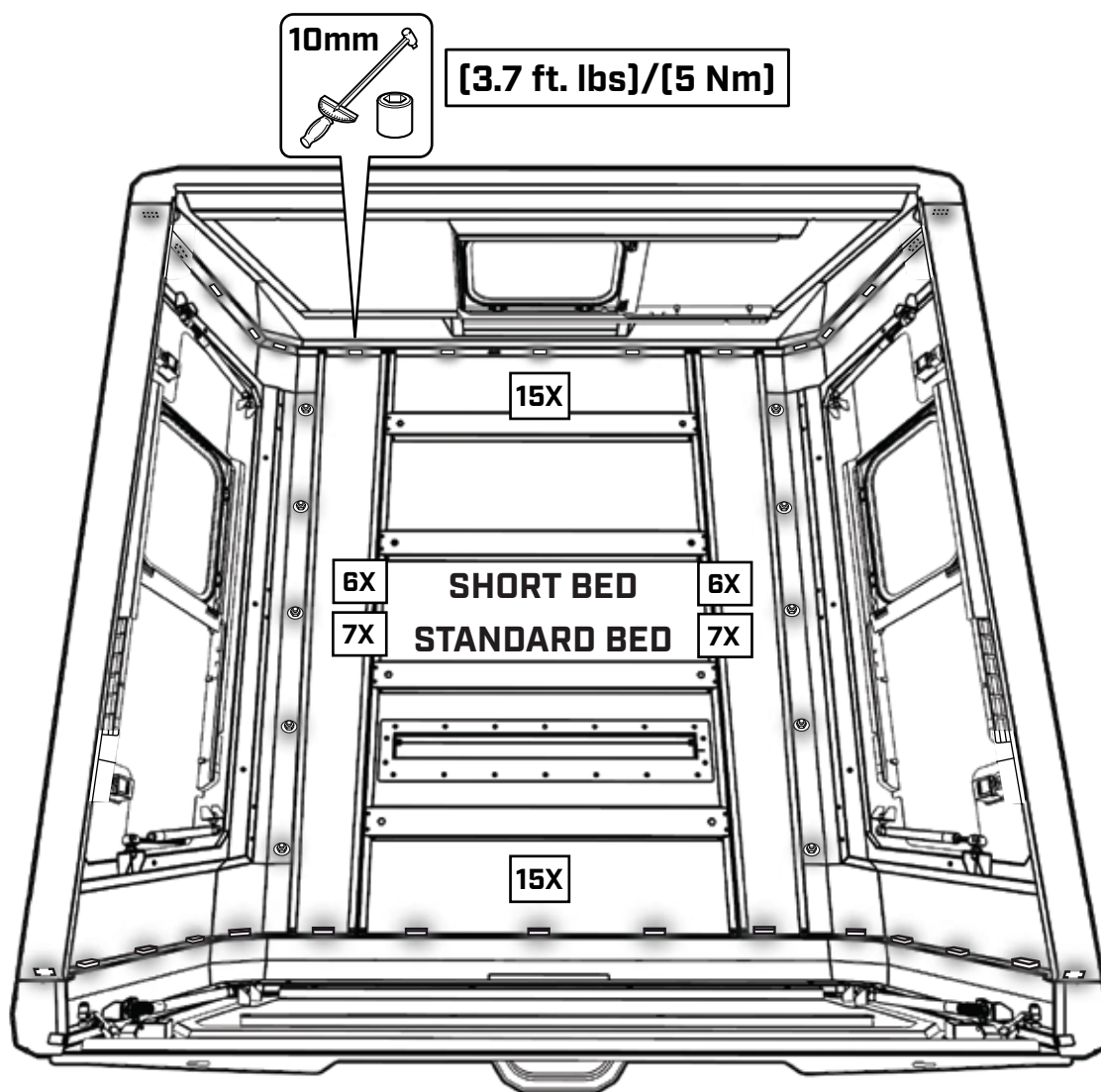

INSTALLATION HARDWARE

ISUZU D-MAX

M6 BOLT



M6 FENDER WASHER

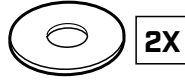

M6 LOCK WASHER



THIN RUBBER PAD

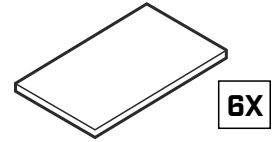

SUPPORT BRACKETS

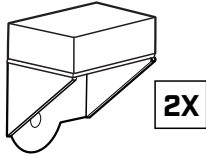

MOUNTING CLAMP

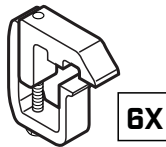

MITSUBISHI TRITON

MOUNTING CLAMP

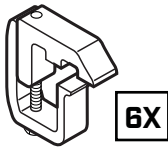

THIN RUBBER PAD

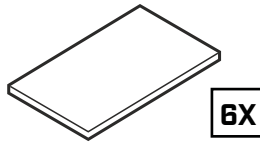

D - RUBBER

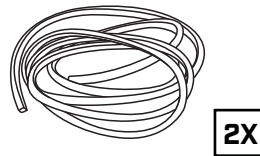

FOAM SEAL TAPE 5MM

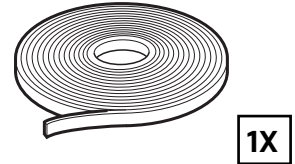

TOYOTA HILUX

REAR BRACKETS

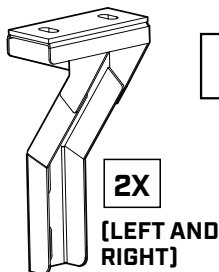

FRONT BRACKETS

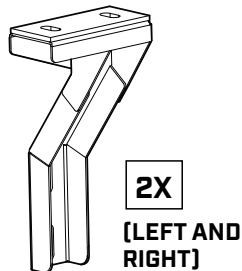

M8 LOCK NUT



M8 FENDER WASHER



M8 LOCK WASHER

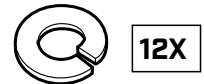

M8 BOLT

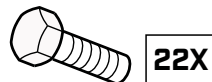

FOAM SEAL TAPE 20MM

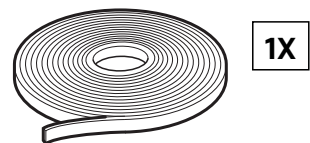

INSTALLATION HARDWARE

VW AMAROK

M8 BOLT

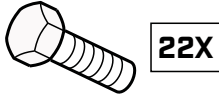

22X

M8 LOCK NUT



10X

REAR BRACKETS

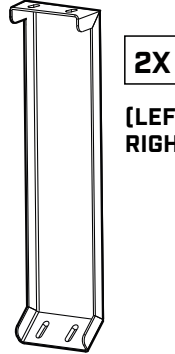

2X

(LEFT AND RIGHT)

FRONT BRACKETS

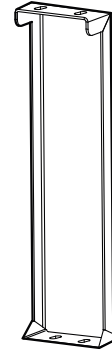

2X

(LEFT AND RIGHT)

M8 FENDER WASHER



30X

M8 LOCK WASHER



12X

THICK RUBBER PADS



8X

TOYOTA LAND CRUISER

DRILL JIG

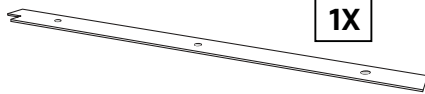

1X

M8 BOLT

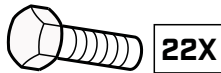

22X

M8 FENDER WASHER



30X

M8 LOCK WASHER



12X

FOAM SEAL TAPE 20MM

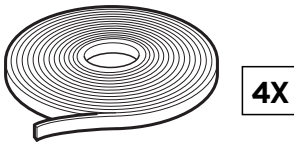

4X

M8 LOCK NUT



10X

PLASTIC END CAPS



10X

D - RUBBER

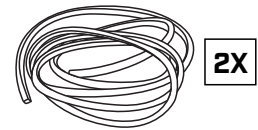

2X

VEHICLE INSTALLATION



IMPORTANT

- ▼ ASSISTANCE WILL BE NEEDED FOR THIS INSTALLATION. FOUR PEOPLE ARE RECOMMENDED TO LIFT THE SMARTCAP ONTO THE VEHICLE.
- ▼ AVOID PINCHING OR CRUSHING HANDS AND FINGERS.
- ▼ BE SURE THE VEHICLE IS TURNED OFF FOR THIS INSTALLATION.
- ▼ READ THROUGH THE ENTIRE PROCEDURE BEFORE STARTING AND FOLLOW THE STEPS CAREFULLY TO ENSURE THE THIRD BRAKE LIGHT WILL FUNCTION PROPERLY.
- ▼ USE A TEST LIGHT TO CHECK FOR SUCCESSFUL INSTALLATION.

STEP 20-30

ISUZU D-MAX

STEP 31-40

MITSUBISHI TRITON

STEP 41-57

TOYOTA HILUX

STEP 58-72

VW AMAROK

STEP 73-85

TOYOTA LAND CRUISER

STEP 20

ISUZU D-MAX

ENSURE THE ENTIRE BOTTOM EDGE OF THE SMARTCAP IS CLEAN.

LOCATE BOTH RETENTION TABS ON THE REAR FLANGE AND BEND EACH TO A 45-DEGREE ANGLE FOR D-RUBBER FITMENT.

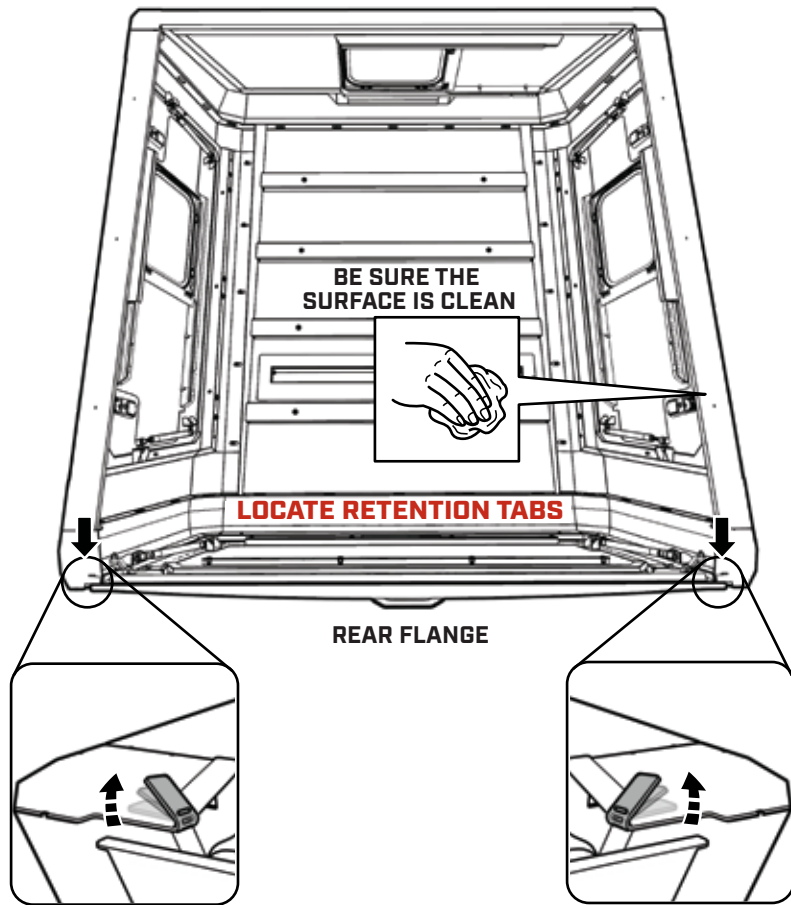

STEP 21

ISUZU D-MAX

TRIM THE D-RUBBER WITH A CLEAN, STRAIGHT CUT.

APPLY 2-3 INCHES SUPER GLUE NEAR THE RETENTION TABS, ALONG THE BOTTOM EDGE OF THE REAR FLANGE

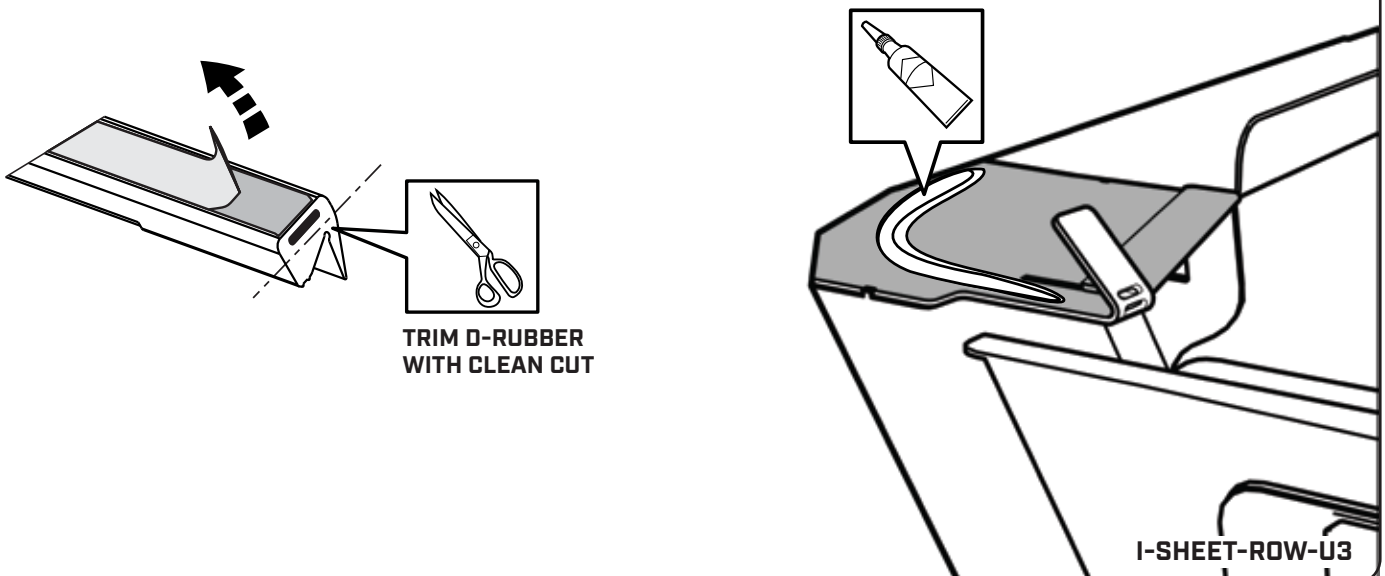
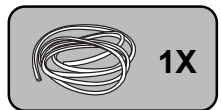

STEP 22

ISUZU D-MAX

FULLY INSERT THE RETENTION TAB INTO THE SLOT ON THE D-RUBBER. ENSURE THE D-RUBBER IS ORIENTED CORRECTLY WITH ITS PROFILE MATCHING THE CONTOUR OF THE REAR FLANGE.

PRESS DOWN FIRMLY ON THE TAB AND THE D-RUBBER TO BOND IT TO THE REAR FLANGE, CREATING A TIGHT SEAL.

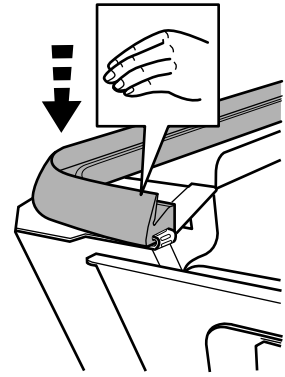
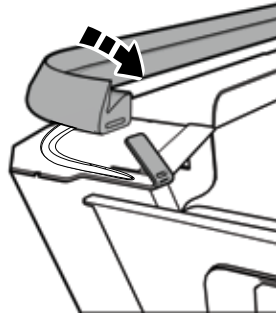

CORRECT D-RUBBER ORIENTATION

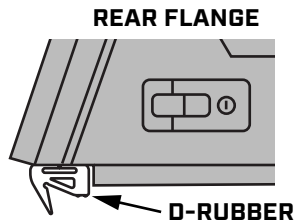

INCORRECT D-RUBBER ORIENTATION

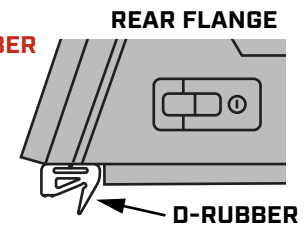

STEP 23

ISUZU D-MAX

ALIGN THE D-RUBBER ALONG THE SMARTCAP'S EDGE, MAINTAINING A CONSISTENT 1/8 INCH GAP FROM THE EDGE.

START FROM ONE CORNER AND WORK YOUR WAY AROUND THE CAP TO ENSURE PROPER PLACEMENT AND ALIGNMENT.

REINFORCE CORNERS WITH SUPER GLUE.

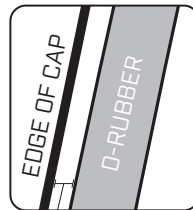

1/8 INCH FROM EDGE

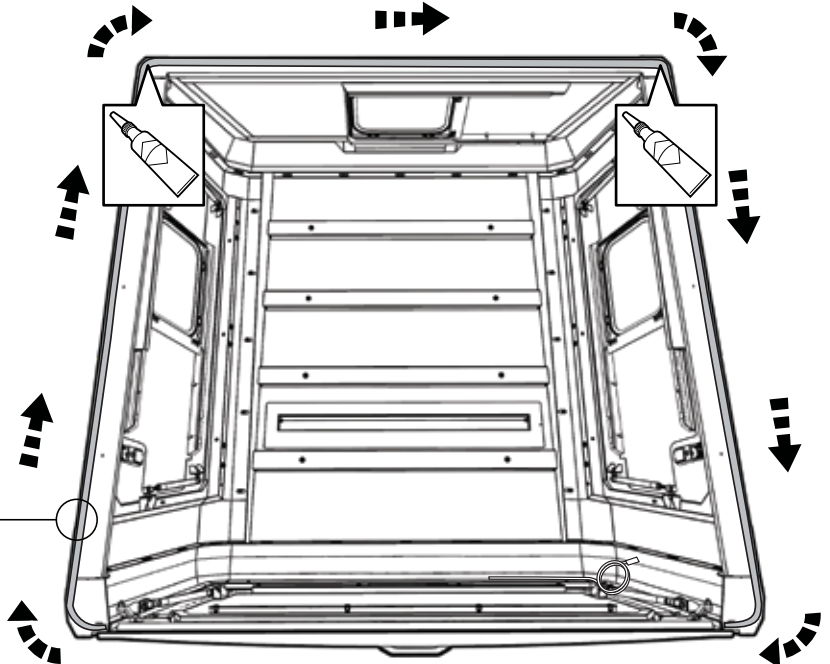

STEP 24

VERSION A

ISUZU D-MAX

TRIM ANY EXCESS D-RUBBER BEYOND THE EDGE FOR A NEAT FINISH.

APPLY 2-3 INCHES OF SUPER GLUE NEAR THE RETENTION TAB, ALONG THE BOTTOM EDGE OF THE REAR FLANGE. FULLY INSERT THE RETENTION TAB INTO THE SLOT ON THE D-RUBBER.

PRESS DOWN FIRMLY ON THE TAB AND THE D-RUBBER TO BOND IT TO THE REAR FLANGE, CREATING A TIGHT SEAL.

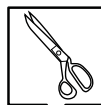

TRIM D-RUBBER WITH CLEAN CUT

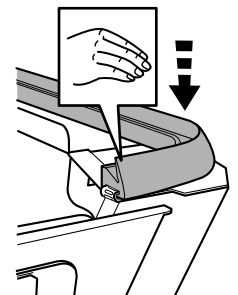
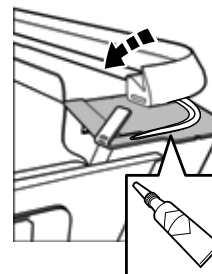
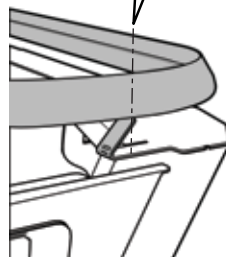





I-SHEET-ROW-U3

STEP 25

ISUZU D-MAX

REMOVE THE REAR HARDWARE FROM THE INNER WALL OF THE TRUCK BED.

TIGHTEN BOTH REAR MOUNTING BRACKETS TO TRUCK BED USING A TORQUE WRENCH TO 4.4 FT. LBS. [6NM] WITH M8 BOLT, M8 LOCK WASHER AND M8 FENDER WASHER AS SHOWN.

-  2X
-  2X
-  2X
-  2X

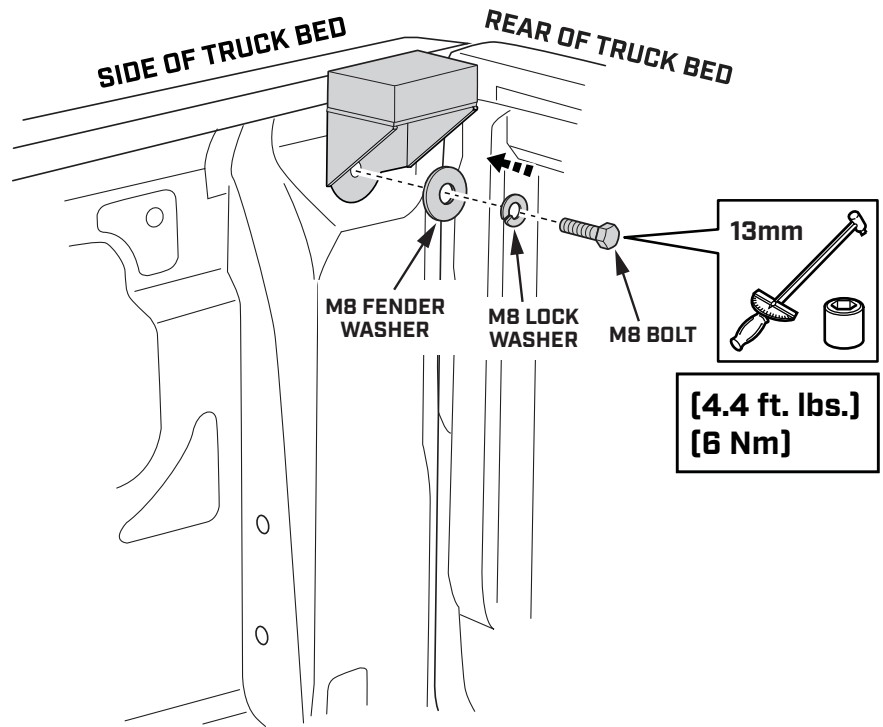

STEP 26

ISUZU D-MAX

USE 4 PEOPLE TO LIFT THE ASSEMBLED SMARTCAP ONTO THE TRUCK BED.

TO AVOID DAMAGE TO THE D-RUBBER, DO NOT SLIDE THE SMARTCAP INTO PLACE.

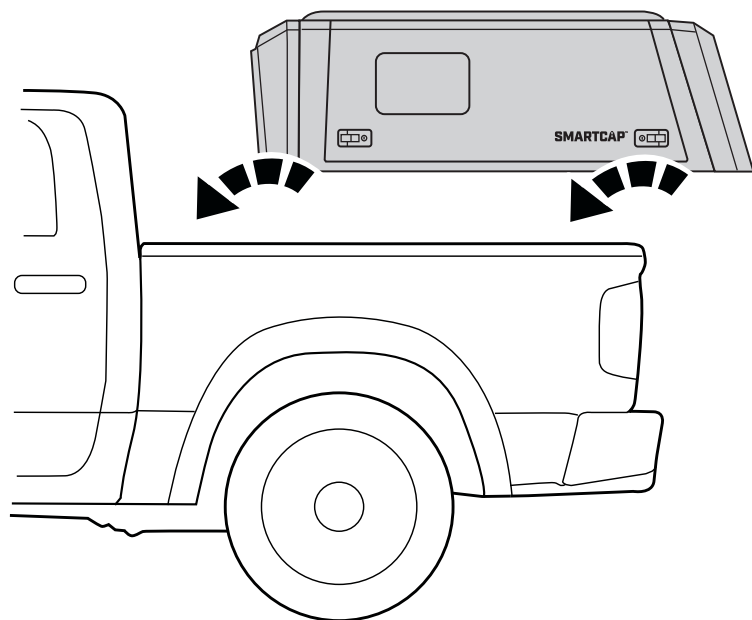

STEP 27

ISUZU D-MAX

CHECK THAT THE SMARTCAP IS PROPERLY POSITIONED AND CENTERED ON THE TRUCK BED.



IT'S IMPORTANT THAT THE SMARTCAP IS NOT PUSHED TOO FAR FORWARD, LEAVING A GAP BETWEEN THE SMARTCAP AND THE CAB.

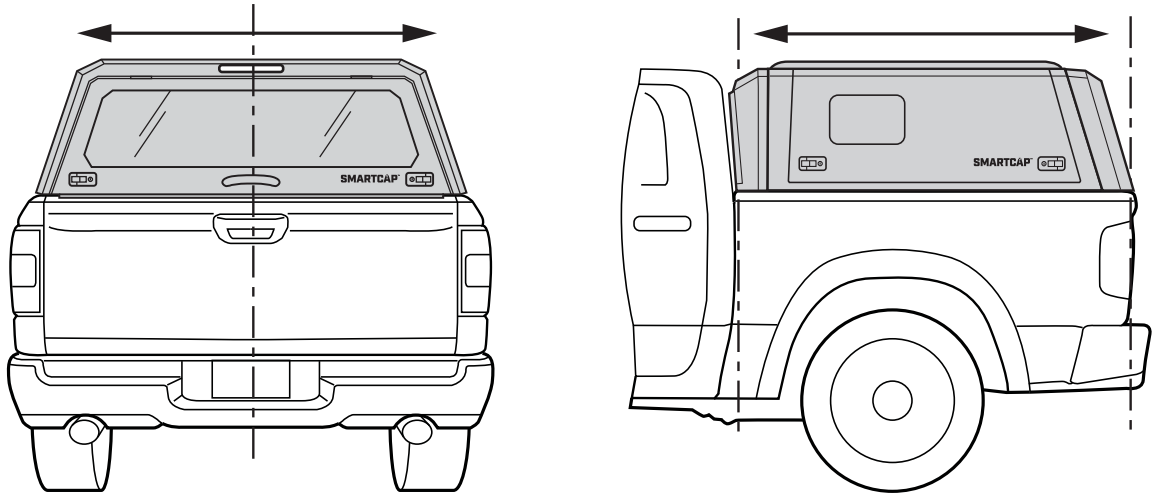

STEP 28

ISUZU D-MAX

WALK AROUND THE TRUCK BED TO MAKE SURE THE D-RUBBER FITMENT IS CORRECT AND THAT THE RUBBER LIP IS PROPERLY TUCKED UNDERNEATH THE CAP.

CORRECT D-RUBBER ORIENTATION



D-RUBBER

REAR FLANGE

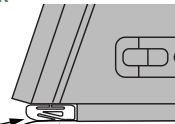

TAILGATE

INCORRECT D-RUBBER ORIENTATION



D-RUBBER

REAR FLANGE



TAILGATE

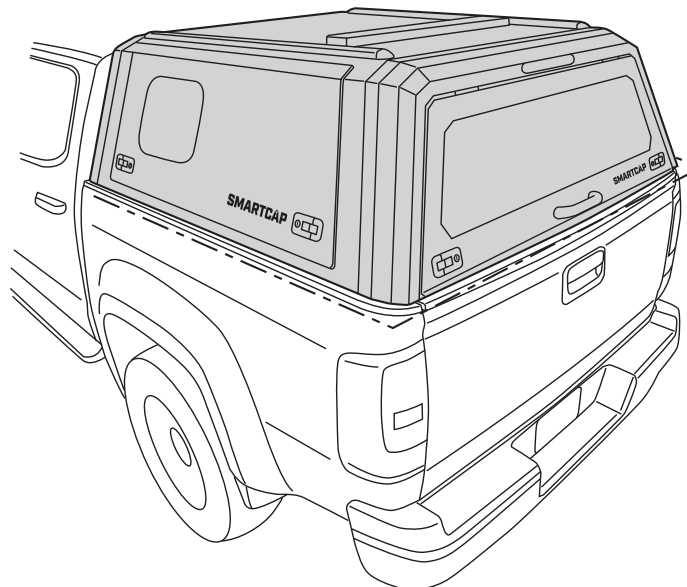

I-SHEET-ROW-U3

STEP 29



ISUZU D-MAX

WITH THE EXCEPTION OF THE REAR CORNERS, PLACE THE THIN RUBBER PADS NEXT TO GUSSETS ON BOTH SIDES OF THE CAP.

3 PADS PER SIDE

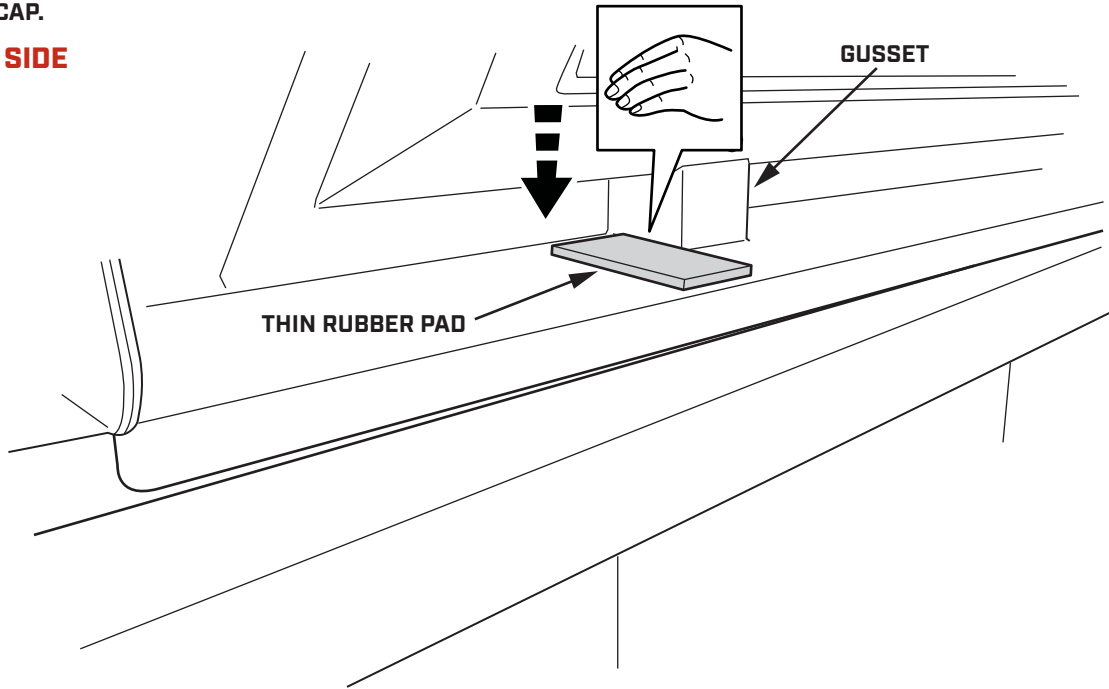

STEP 30



ISUZU D-MAX

ONCE ALL PADS ARE IN PLACE, INSTALL MOUNTING CLAMPS ON TOP OF THIN RUBBER PADS USING TORQUE WRENCH AND 13MM SOCKET. TIGHTEN CLAMPS TO 4.4 FT. LBS. [6 NEWTON METERS]

3 CLAMPS PER SIDE

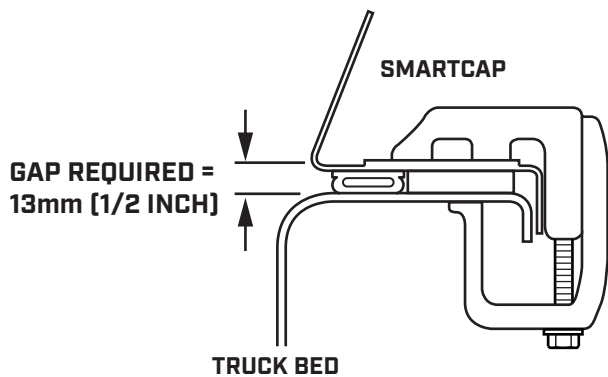
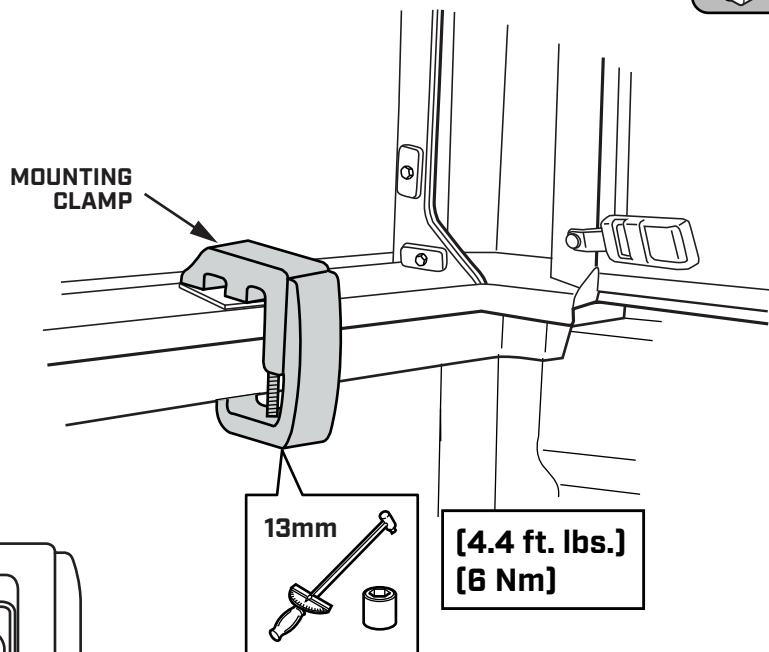

STEP 31

MITSUBISHI TRITON

APPLY FOAM SEAL TAPE TO FRONT
EDGE OF THE SMARTCAP.

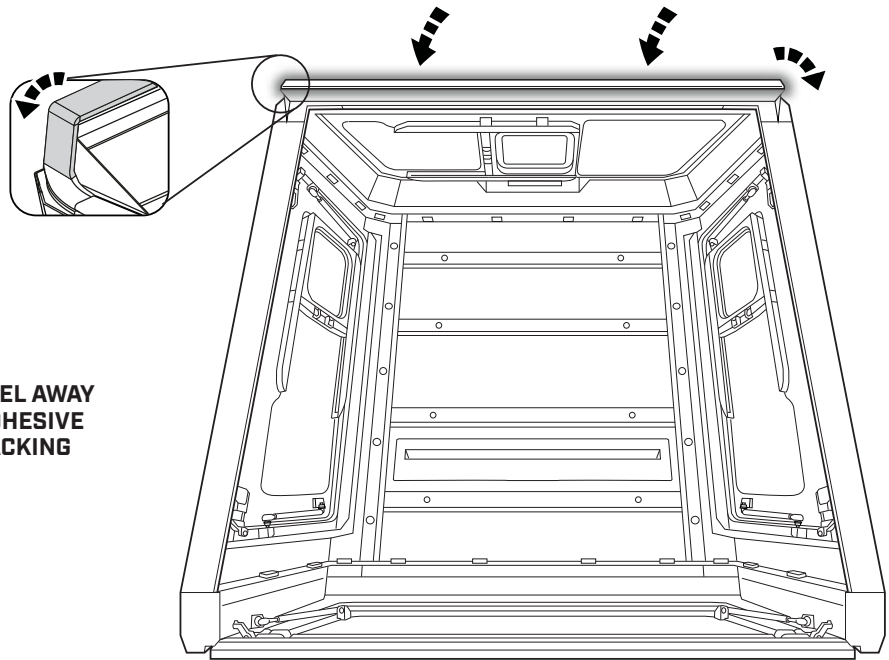
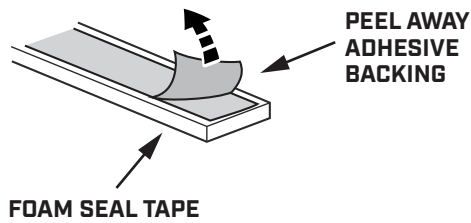

STEP 32

MITSUBISHI TRITON

ENSURE THE ENTIRE BOTTOM
EDGE OF THE SMARTCAP IS CLEAN.

LOCATE BOTH RETENTION TABS ON
THE REAR FLANGE AND BEND EACH
TO A 45-DEGREE ANGLE FOR
D-RUBBER FITMENT.

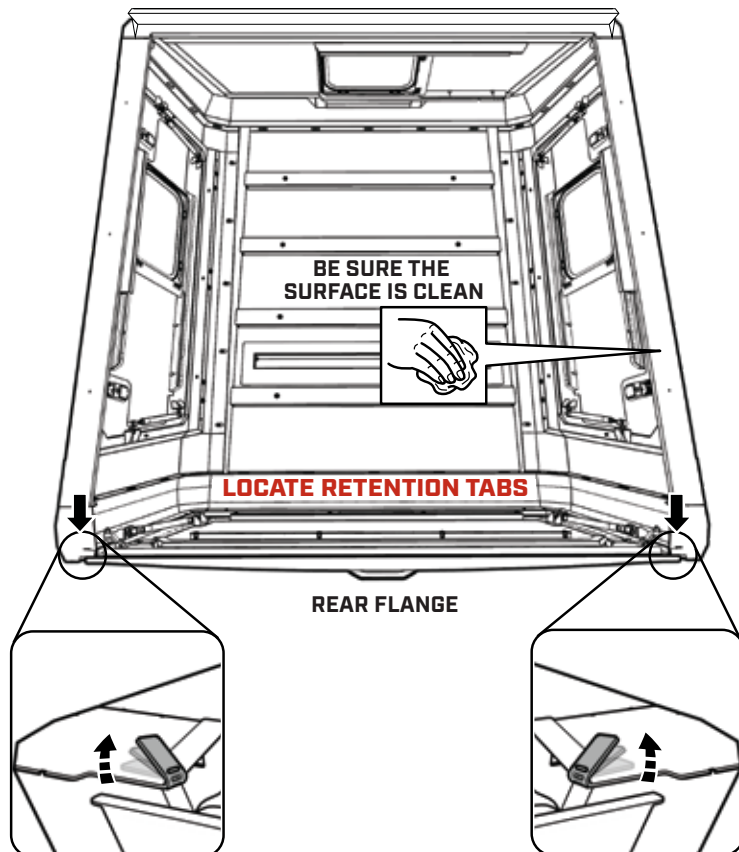

I-SHEET-ROW-U3

STEP 33

MITSUBISHI TRITON

TRIM THE D-RUBBER WITH A CLEAN, STRAIGHT CUT.

APPLY 2-3 INCHES SUPER GLUE NEAR THE RETENTION TABS, ALONG THE BOTTOM EDGE OF THE REAR FLANGE

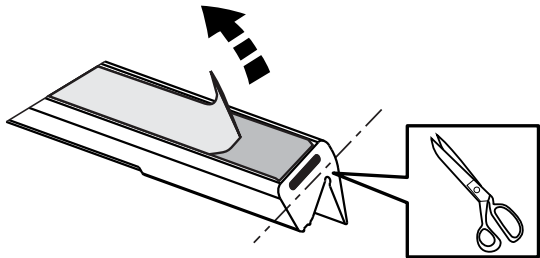

TRIM D-RUBBER WITH CLEAN CUT

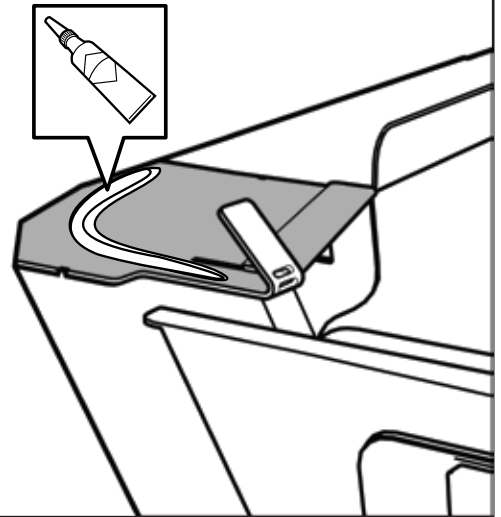

STEP 34

MITSUBISHI TRITON

FULLY INSERT THE RETENTION TAB INTO THE SLOT ON THE D-RUBBER. ENSURE THE D-RUBBER IS ORIENTED CORRECTLY WITH ITS PROFILE MATCHING THE CONTOUR OF THE REAR FLANGE.

PRESS DOWN FIRMLY ON THE TAB AND THE D-RUBBER TO BOND IT TO THE REAR FLANGE, CREATING A TIGHT SEAL.

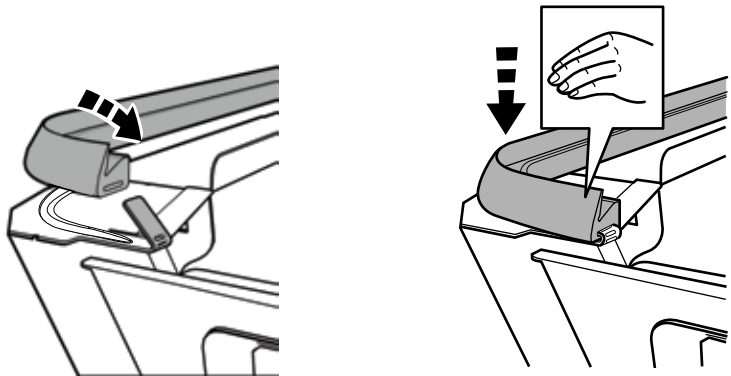

CORRECT D-RUBBER ORIENTATION

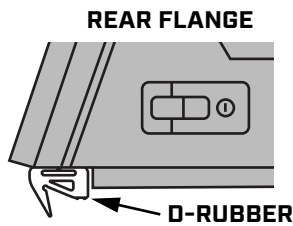

INCORRECT D-RUBBER ORIENTATION

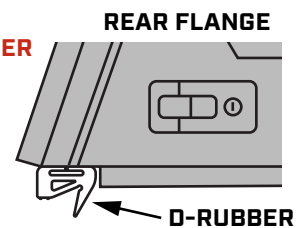

STEP 35

MITSUBISHI TRITON

ALIGN THE D-RUBBER ALONG THE SMARTCAP'S EDGE, MAINTAINING A CONSISTENT 1/8 INCH GAP FROM THE EDGE.

START FROM ONE CORNER AND WORK YOUR WAY AROUND THE CAP TO ENSURE PROPER PLACEMENT AND ALIGNMENT.

REPEAT PROCESS FOR OPPOSITE SIDE.

REINFORCE CORNERS WITH SUPER GLUE.

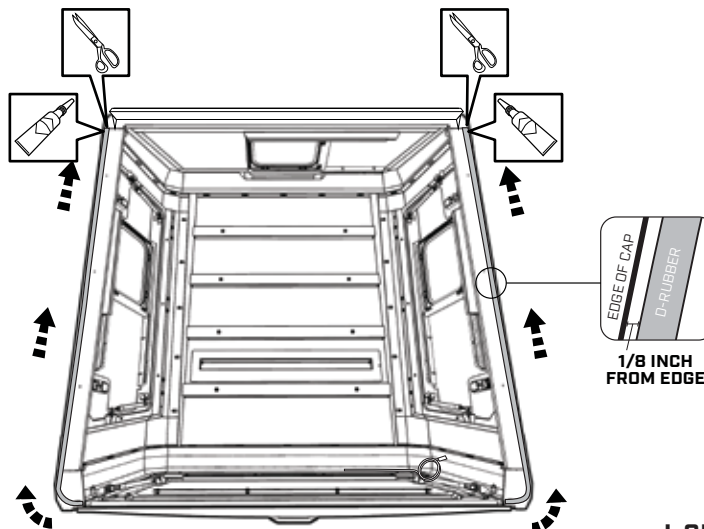

I-SHEET-ROW-U3

STEP 36

MITSUBISHI TRITON

USE 4 PEOPLE TO LIFT THE ASSEMBLED SMARTCAP ONTO THE TRUCK BED.



TO AVOID DAMAGE TO THE D-RUBBER, DO NOT SLIDE THE SMARTCAP INTO PLACE.

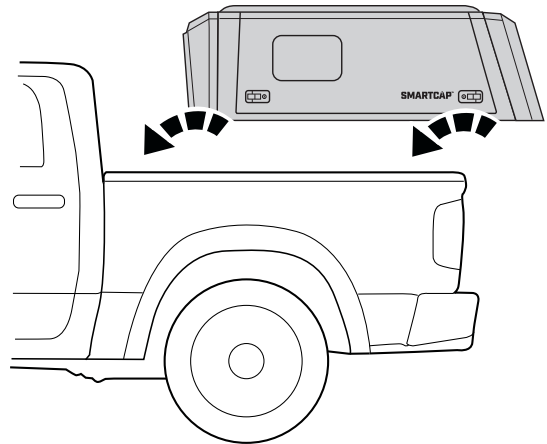

STEP 37

MITSUBISHI TRITON

CHECK THAT THE SMARTCAP IS PROPERLY POSITIONED AND CENTERED ON THE TRUCK BED.



IT'S IMPORTANT THAT THE SMARTCAP IS NOT PUSHED TOO FAR FORWARD, LEAVING A GAP BETWEEN THE SMARTCAP AND THE CAB.

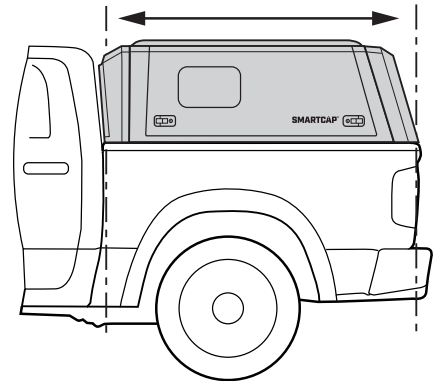
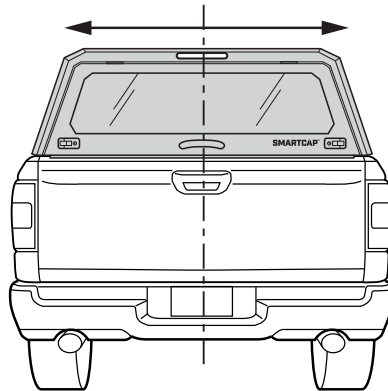

STEP 38

MITSUBISHI TRITON

WALK AROUND THE TRUCK BED TO MAKE SURE THE D-RUBBER FITMENT IS CORRECT AND THAT THE RUBBER LIP IS PROPERLY TUCKED UNDERNEATH THE CAP.

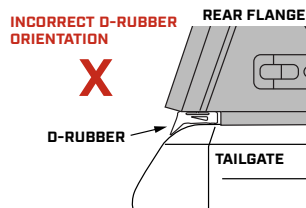
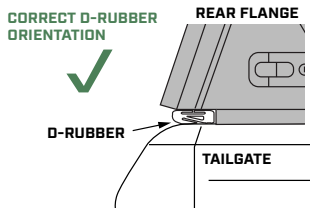
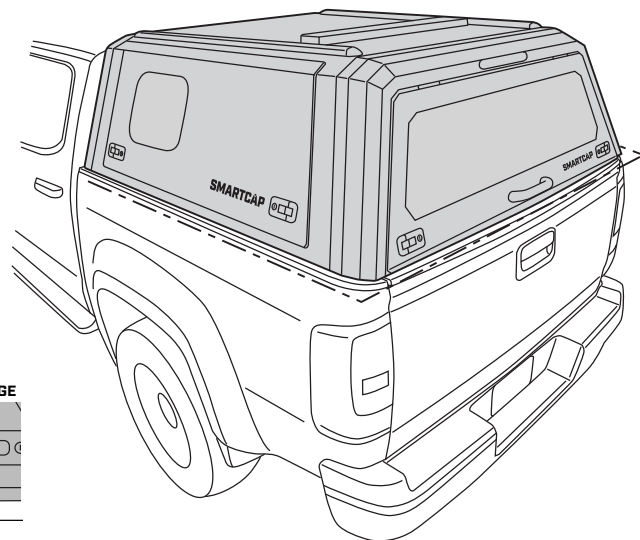

I-SHEET-ROW-U2

STEP 39

MITSUBISHI TRITON

WITH THE EXCEPTION OF THE REAR CORNERS, PLACE THE THIN RUBBER PADS NEXT TO GUSSETS ON BOTH SIDES OF THE CAP.

3 PADS PER SIDE

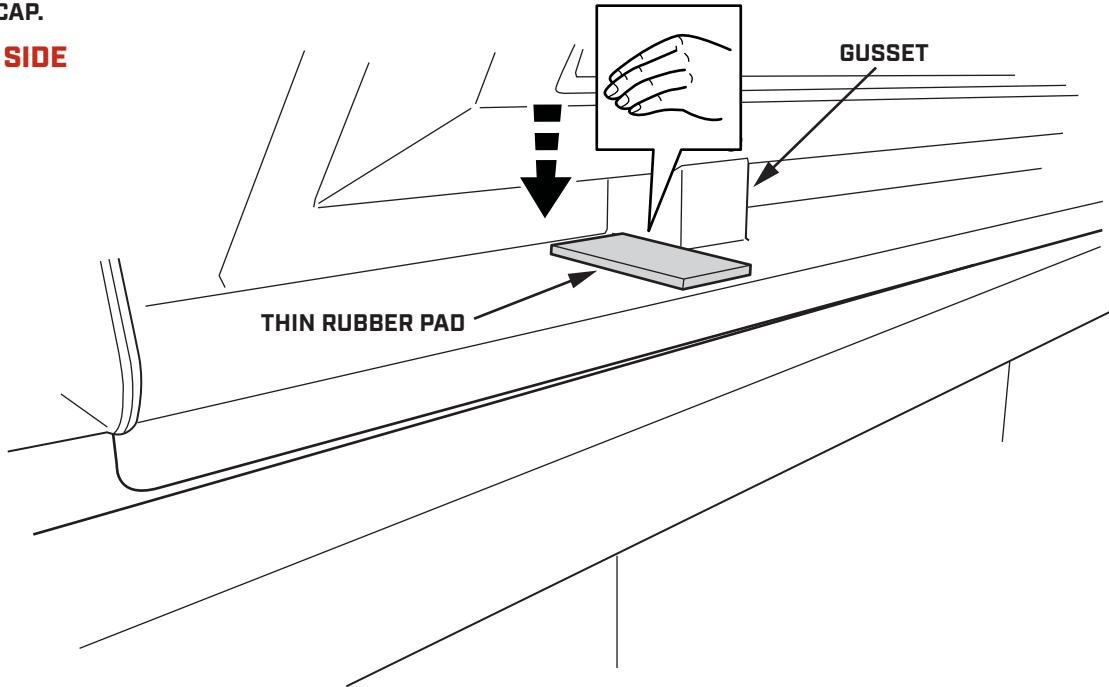
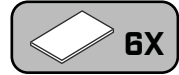

STEP 40

MITSUBISHI TRITON

ONCE ALL PADS ARE IN PLACE, INSTALL MOUNTING CLAMPS ON TOP OF THIN RUBBER PADS USING TORQUE WRENCH AND 13MM SOCKET. TIGHTEN CLAMPS TO 4.4 FT. LBS. [6 NEWTON METERS]

3 CLAMPS PER SIDE

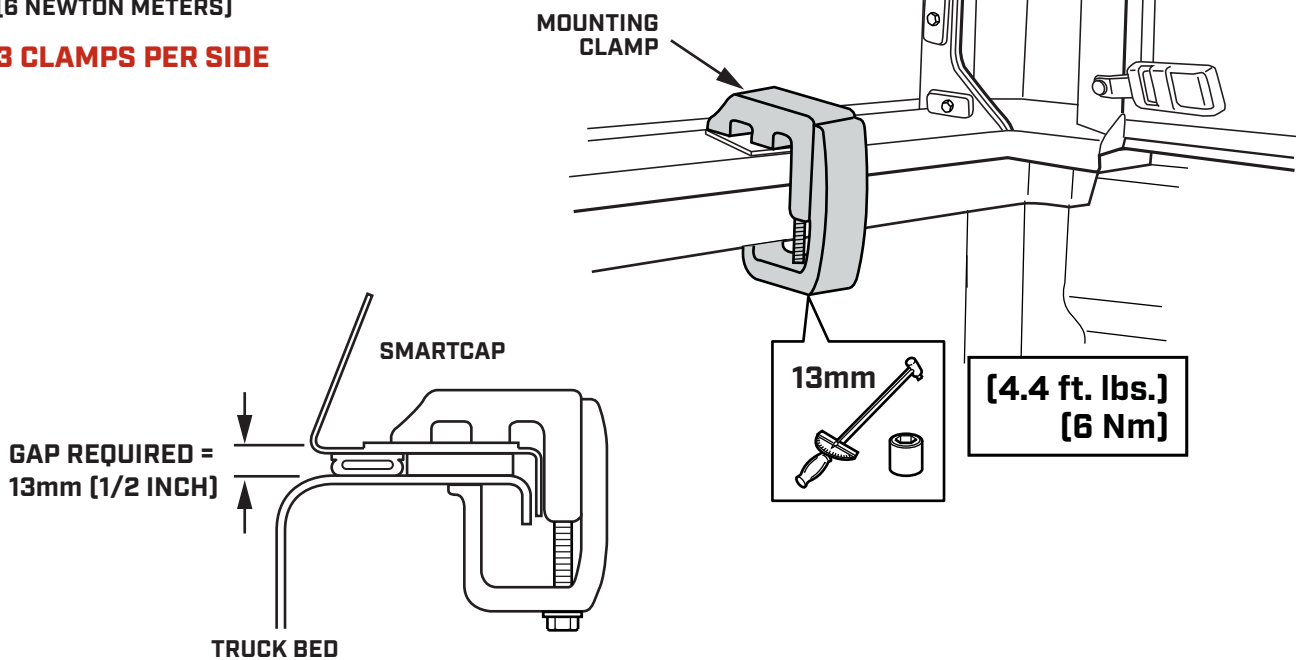

I-SHEET-ROW-U3

STEP 41

TOYOTA HILUX

ENSURE THE ENTIRE BOTTOM EDGE OF THE SMARTCAP IS CLEAN.

LOCATE BOTH RETENTION TABS ON THE REAR FLANGE AND BEND EACH TO A 45-DEGREE ANGLE FOR D-RUBBER FITMENT.

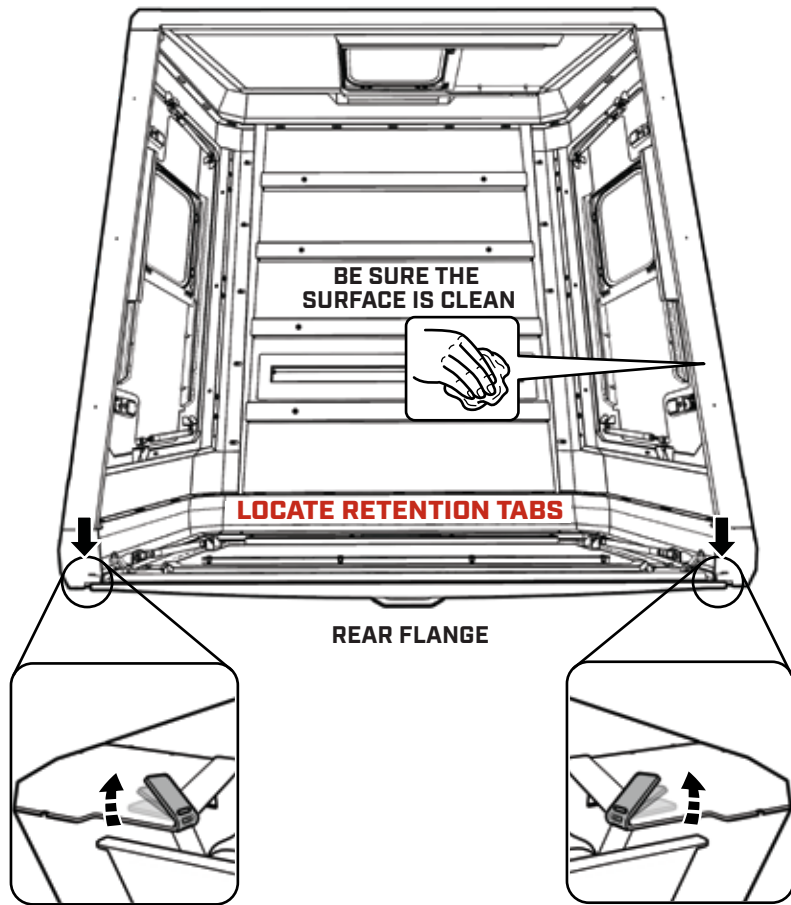

STEP 42

TOYOTA HILUX

TRIM THE D-RUBBER WITH A CLEAN, STRAIGHT CUT.

APPLY 2-3 INCHES SUPER GLUE NEAR THE RETENTION TABS, ALONG THE BOTTOM EDGE OF THE REAR FLANGE

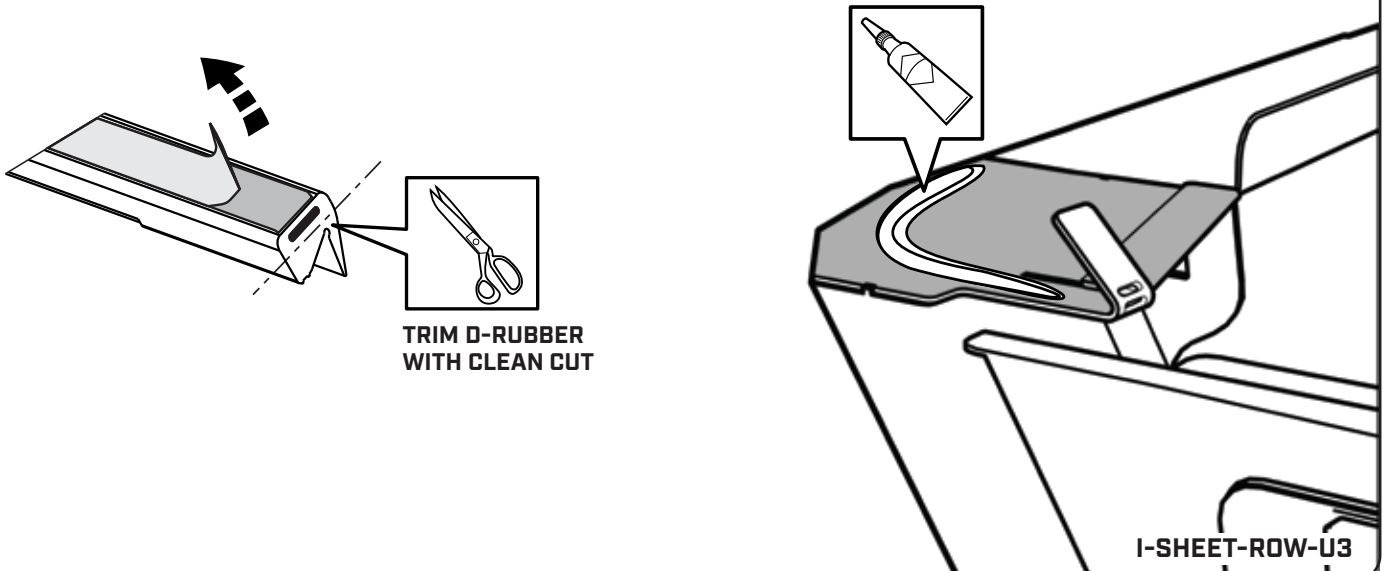
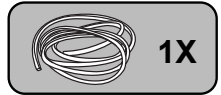

I-SHEET-ROW-U3

STEP 43

TOYOTA HILUX

FULLY INSERT THE RETENTION TAB INTO THE SLOT ON THE D-RUBBER. ENSURE THE D-RUBBER IS ORIENTED CORRECTLY WITH ITS PROFILE MATCHING THE CONTOUR OF THE REAR FLANGE.

PRESS DOWN FIRMLY ON THE TAB AND THE D-RUBBER TO BOND IT TO THE REAR FLANGE, CREATING A TIGHT SEAL.

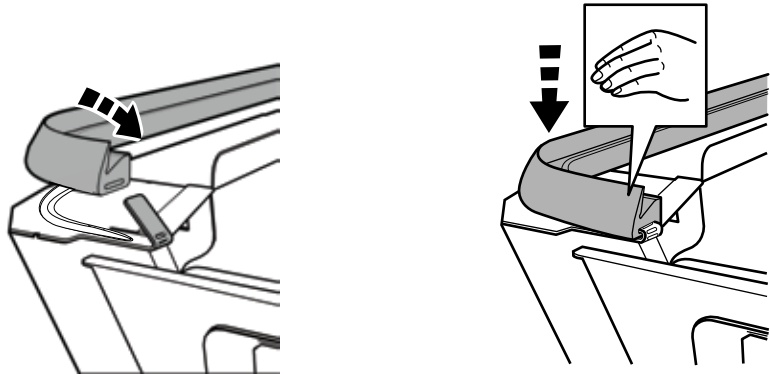

CORRECT D-RUBBER ORIENTATION

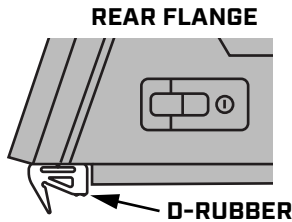

INCORRECT D-RUBBER ORIENTATION

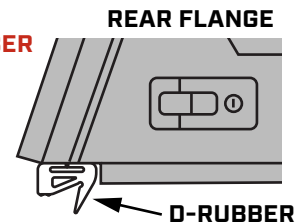

STEP 44

TOYOTA HILUX

ALIGN THE D-RUBBER ALONG THE SMARTCAP'S EDGE, MAINTAINING A CONSISTENT 1/8 INCH GAP FROM THE EDGE.

START FROM ONE CORNER AND WORK YOUR WAY AROUND THE CAP TO ENSURE PROPER PLACEMENT AND ALIGNMENT.

REINFORCE CORNERS WITH SUPER GLUE.

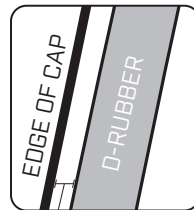

1/8 INCH FROM EDGE

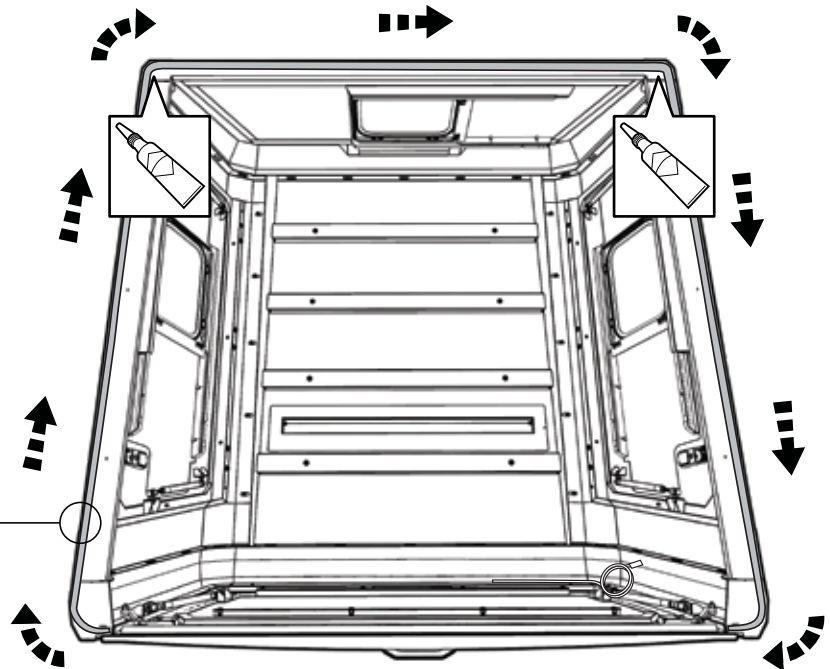

STEP 45

TOYOTA HILUX

TRIM ANY EXCESS D-RUBBER BEYOND THE EDGE FOR A NEAT FINISH.

APPLY 2-3 INCHES OF SUPER GLUE NEAR THE RETENTION TAB, ALONG THE BOTTOM EDGE OF THE REAR FLANGE. FULLY INSERT THE RETENTION TAB INTO THE SLOT ON THE D-RUBBER.

PRESS DOWN FIRMLY ON THE TAB AND THE D-RUBBER TO BOND IT TO THE REAR FLANGE, CREATING A TIGHT SEAL.

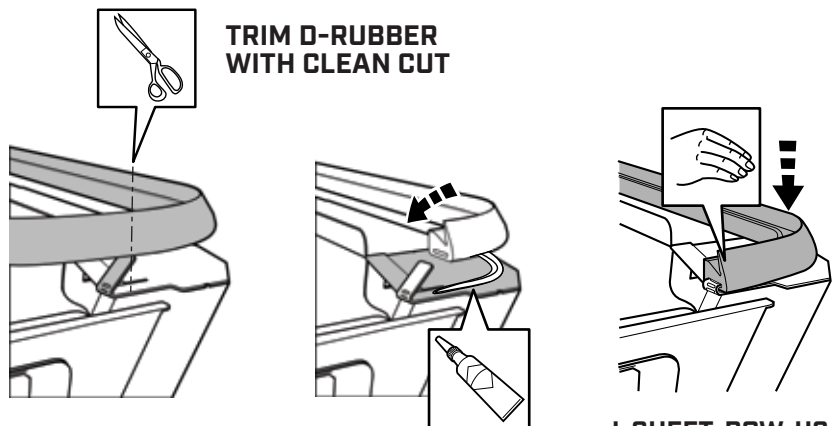

I-SHEET-ROW-U3

STEP 46

TOYOTA HILUX

INSPECT THE TRUCK BED. IF FRONT EDGE IS LOWER THAN THE SIDES, ADD FOAM SEAL TAPE TO THE FRONT EDGE OF THE BED.

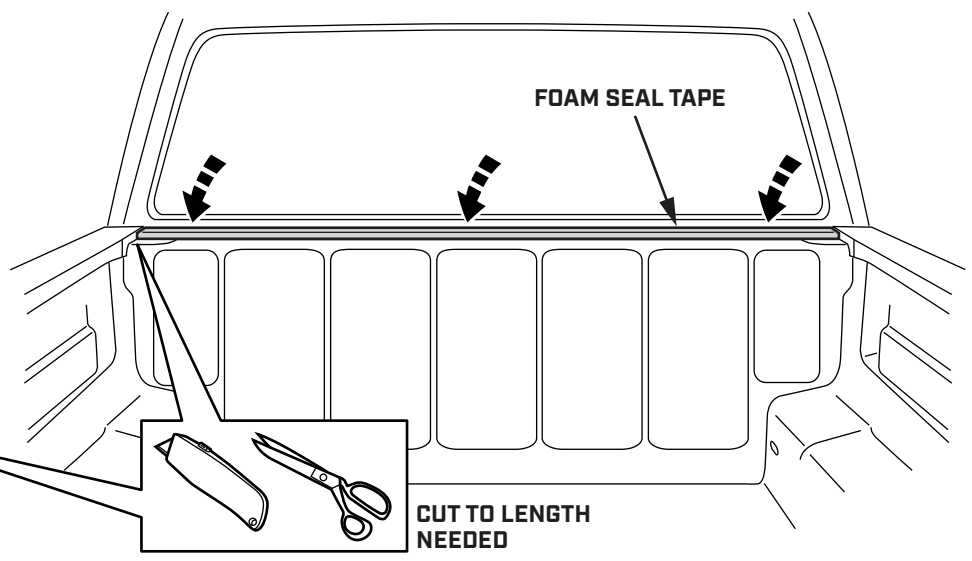
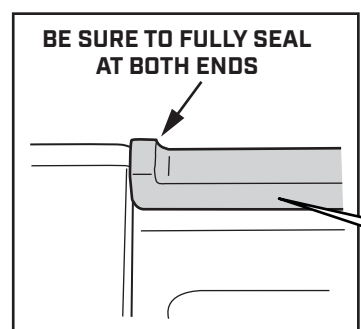
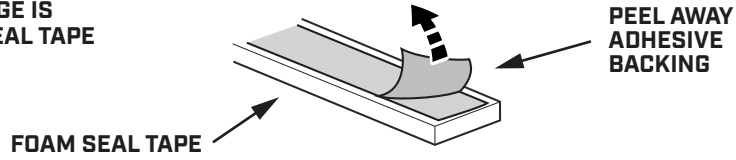
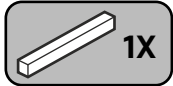

STEP 47

TOYOTA HILUX

REMOVE THE FRONT TIE DOWN HOOK FROM THE INNER WALL OF THE TRUCK BED.

HAND TIGHTEN BOTH FRONT MOUNTING BRACKETS TO TRUCK BED WITH M8 BOLT, M8 LOCK WASHER, TIE DOWN HOOK AND M8 FENDER WASHER AS SHOWN.

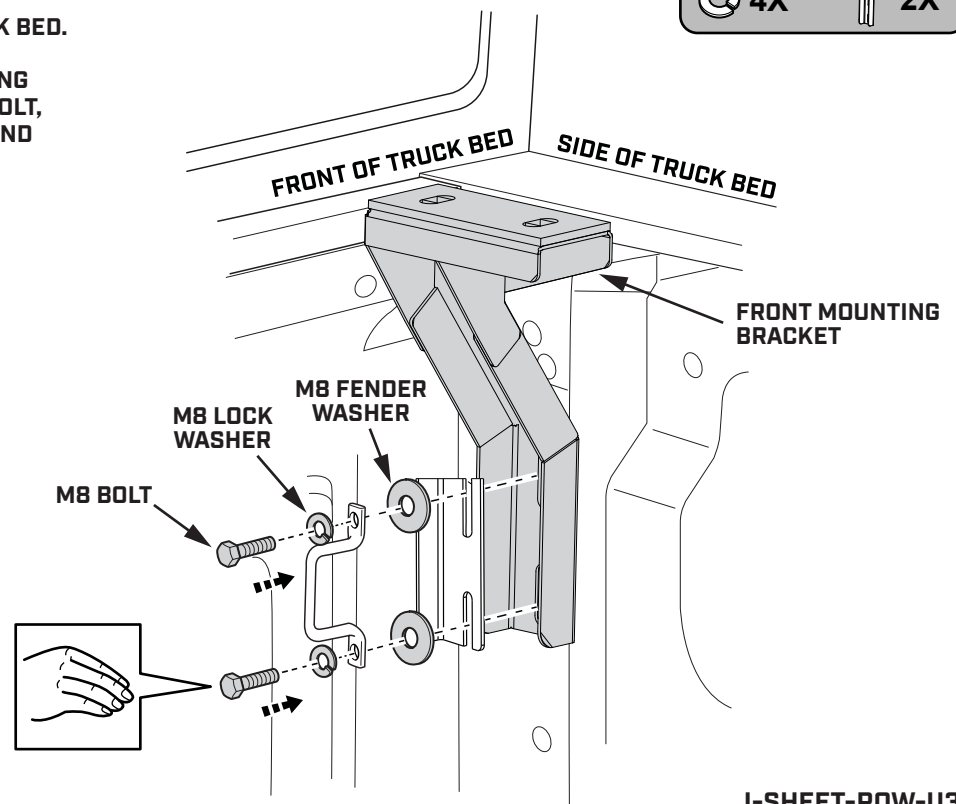
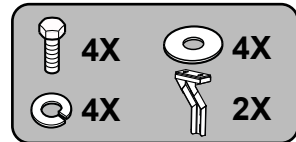

I-SHEET-ROW-U3

STEP 48

TOYOTA HILUX

REMOVE THE REAR TIE DOWN A HOOK FROM THE INNER WALL OF THE TRUCK BED.

HAND TIGHTEN BOTH REAR MOUNTING BRACKETS TO TRUCK BED WITH M8 BOLT, M8 LOCK WASHER, TIE DOWN HOOK AND M8 FENDER WASHER AS SHOWN.

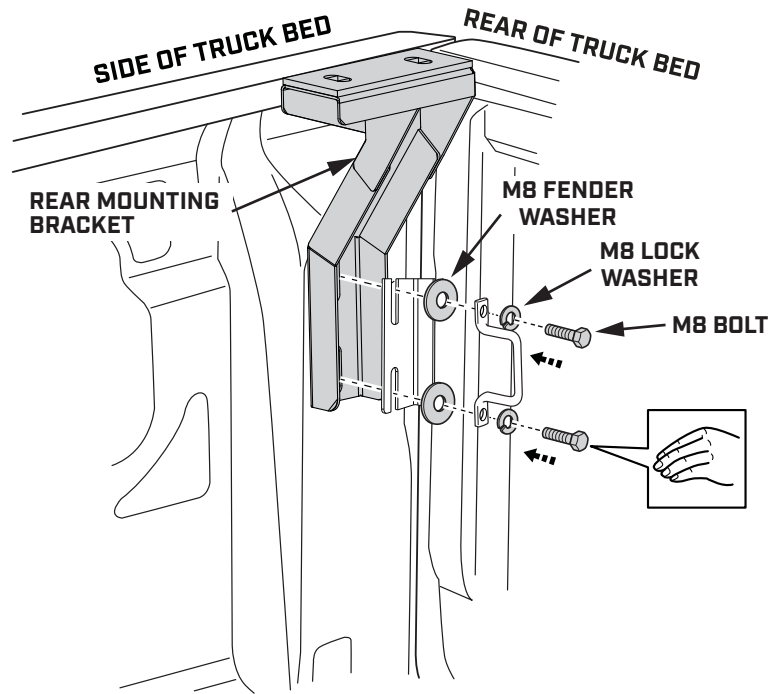
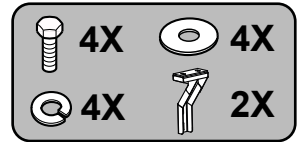

STEP 49

TOYOTA HILUX

USE 4 PEOPLE TO LIFT THE ASSEMBLED SMARTCAP ONTO THE TRUCK BED.

TO AVOID DAMAGE TO THE D-RUBBER, DO NOT SLIDE THE SMARTCAP INTO PLACE.

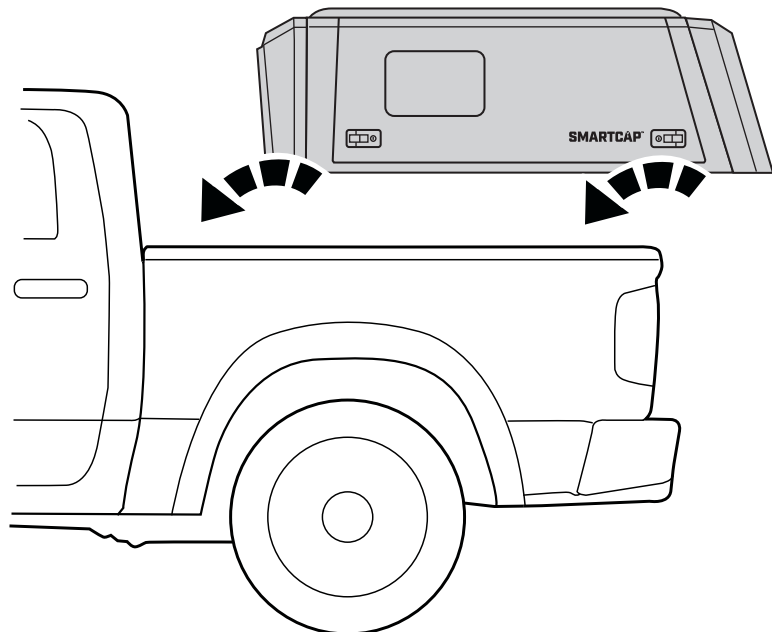

I-SHEET-ROW-U3

STEP 50

TOYOTA HILUX

CHECK THAT THE SMARTCAP IS PROPERLY POSITIONED AND CENTERED ON THE TRUCK BED.



IT'S IMPORTANT THAT THE SMARTCAP IS NOT PUSHED TOO FAR FORWARD, LEAVING A GAP BETWEEN THE SMARTCAP AND THE CAB.

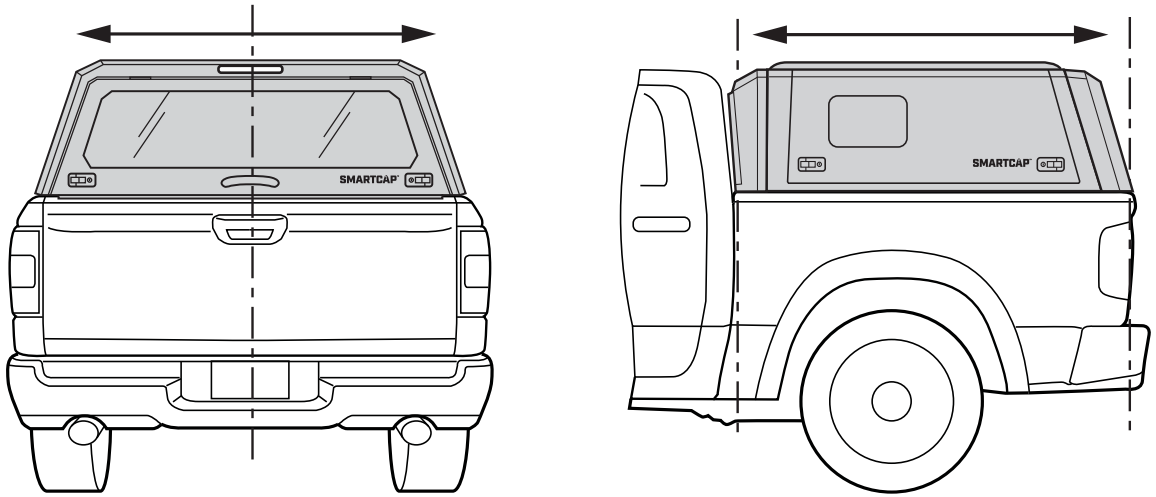

STEP 51

TOYOTA HILUX

WALK AROUND THE TRUCK BED TO MAKE SURE THE D-RUBBER FITMENT IS CORRECT AND THAT THE RUBBER LIP IS PROPERLY TUCKED UNDERNEATH THE CAP.

CORRECT D-RUBBER ORIENTATION



D-RUBBER

REAR FLANGE

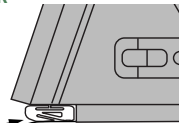

TAILGATE

INCORRECT D-RUBBER ORIENTATION



D-RUBBER

REAR FLANGE

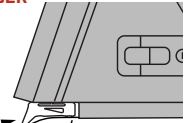

TAILGATE

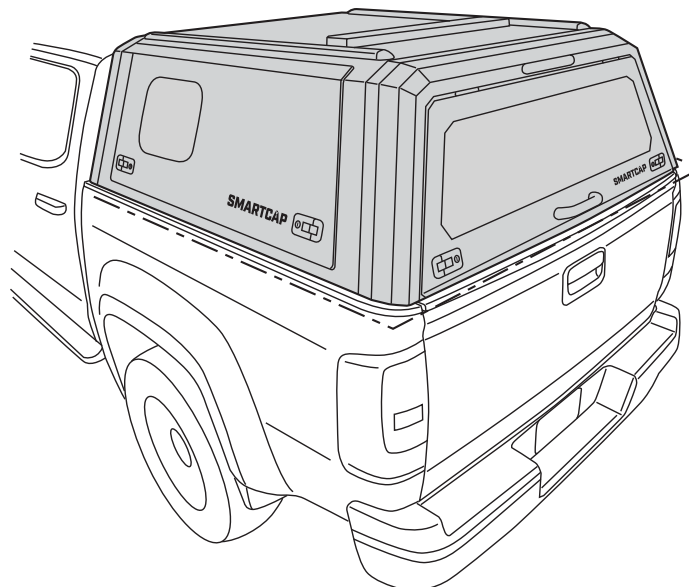

I-SHEET-ROW-U3

STEP 52

TOYOTA HILUX

SECURE BOTH FRONT MOUNTING BRACKETS TO THE SMARTCAP WITH M8 BOLTS, M8 FENDER WASHERS AND M8 LOCK NUT AS SHOWN, HAND TIGHTEN ONLY.

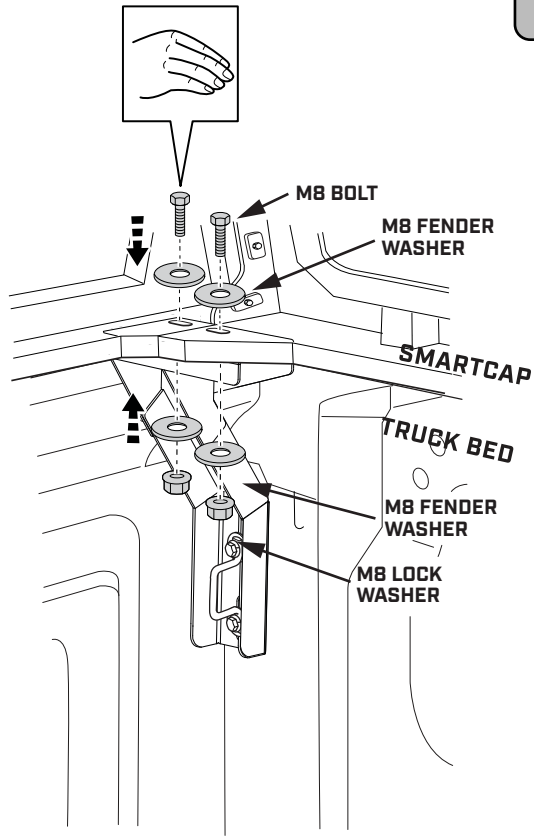

STEP 53

TOYOTA HILUX

SECURE BOTH REAR MOUNTING BRACKETS TO THE SMARTCAP WITH M8 BOLTS, M8 FENDER WASHERS AND M8 LOCK NUT AS SHOWN, HAND TIGHTEN ONLY.

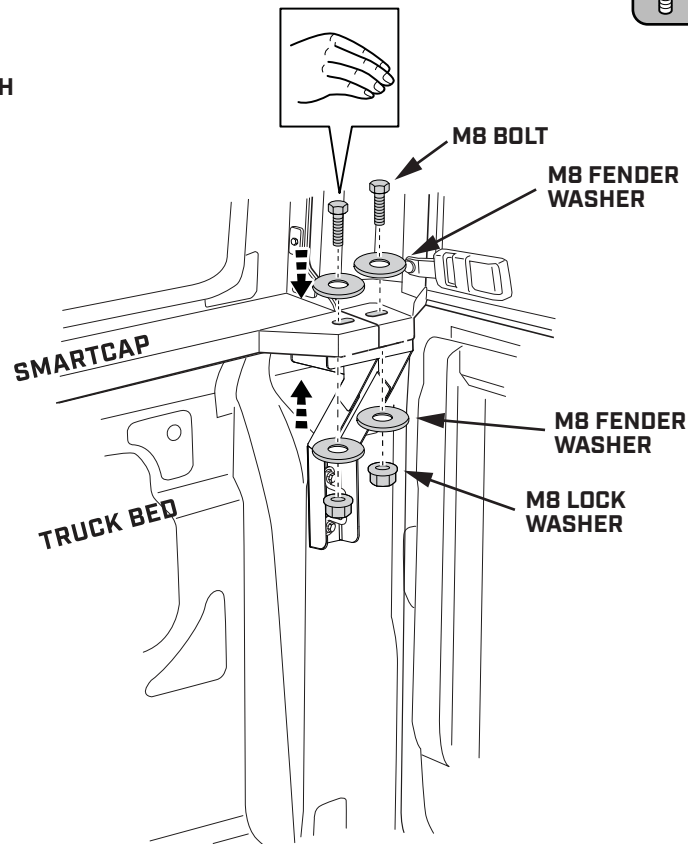
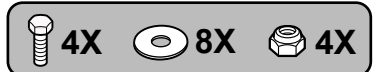

I-SHEET-ROW-U3

STEP 54

TOYOTA HILUX

PARTIALLY TIGHTEN FASTENERS TO THE SMARTCAP ON ALL FOUR MOUNTING BRACKETS USING THE SOCKET WRENCH AND 13MM SOCKET.

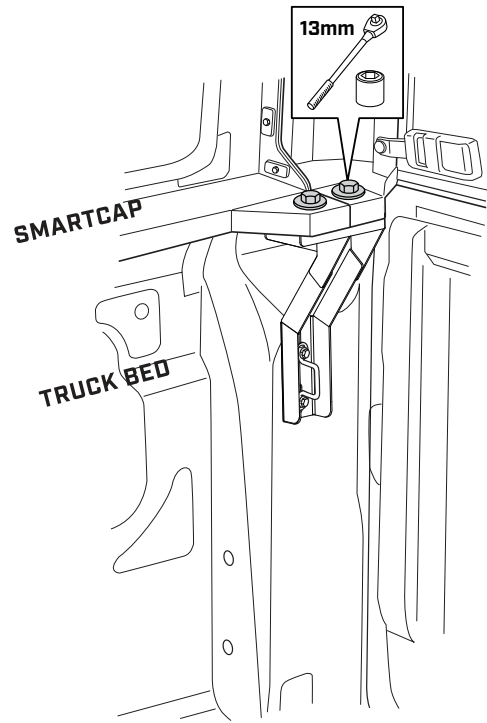
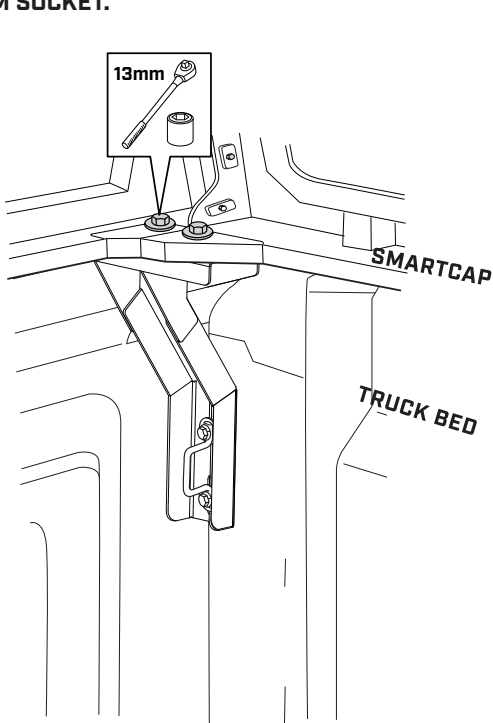

STEP 55

TOYOTA HILUX

PRESS DOWN ON EACH CORNER OF THE SMARTCAP TO ACHIEVE 2MM - 3MM COMPRESSION ON D-RUBBER AND PARTIALLY TIGHTEN FRONT BRACKET FASTENERS WITH SOCKET WRENCH AND 13MM SOCKET.

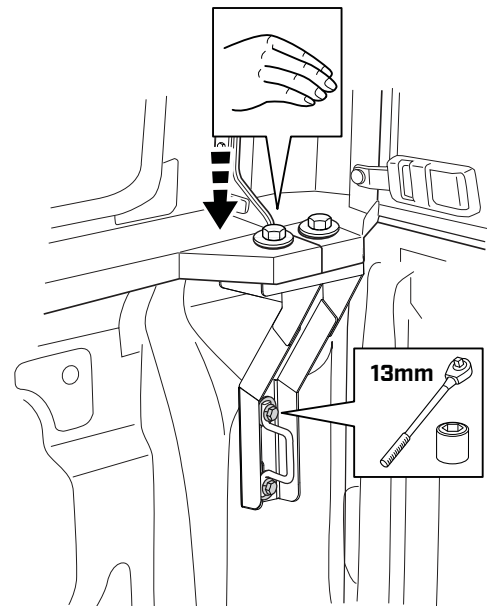
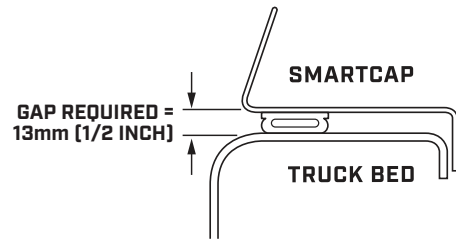
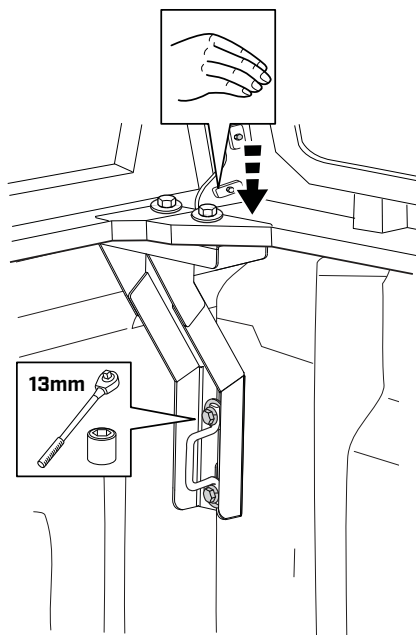

I-SHEET-ROW-U3

STEP 56

TOYOTA HILUX

FULLY TIGHTEN FASTENERS TO THE SMARTCAP ON ALL FOUR MOUNTING BRACKETS USING THE TORQUE WRENCH AND 13MM SOCKET TO 4.4 FT. LBS. (6 NM).

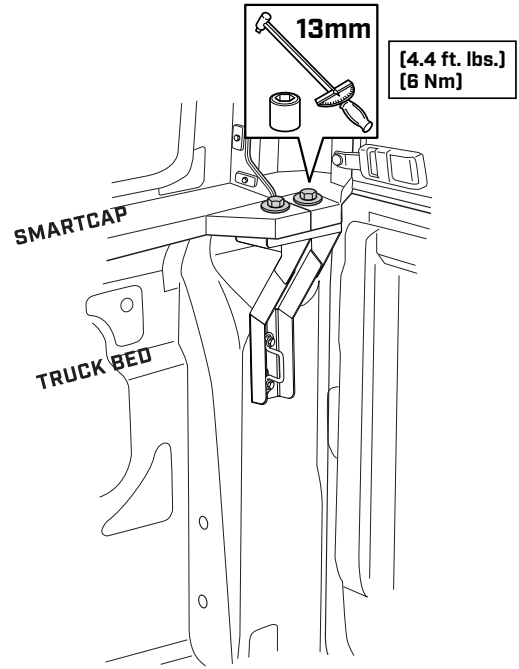
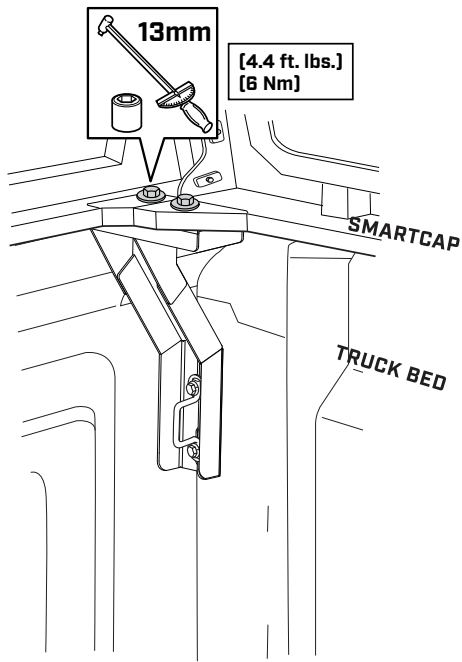

STEP 57

TOYOTA HILUX

FULLY TIGHTEN FASTENERS TO THE TRUCK BED ON ALL FOUR MOUNTING BRACKETS USING THE TORQUE WRENCH AND 13MM SOCKET TO 9 FT. LBS. (12.2 NM).

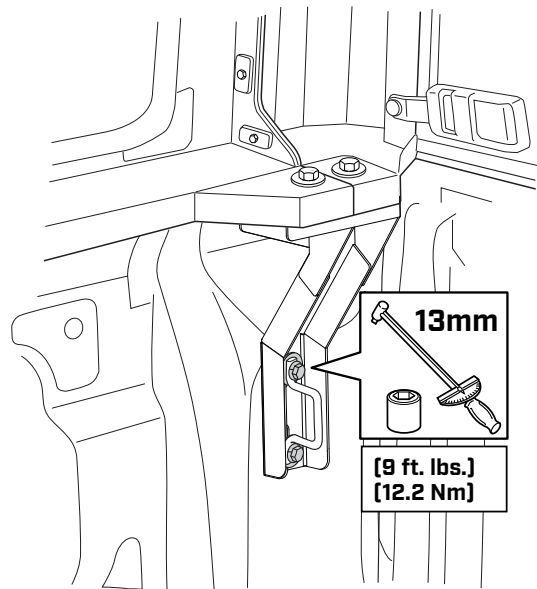
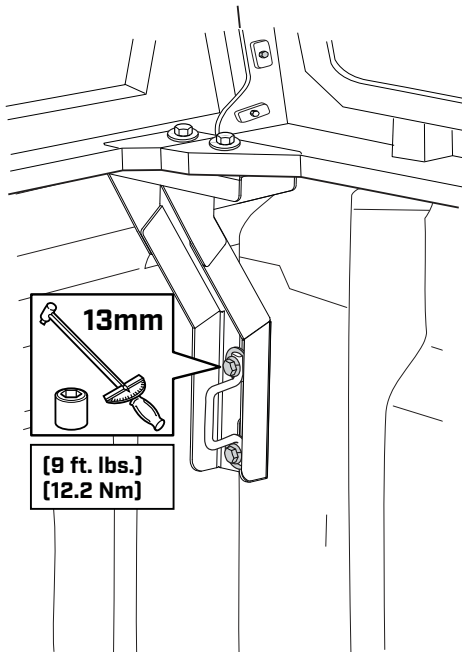

I-SHEET-ROW-U3

STEP 58

VW AMAROK

ENSURE THE ENTIRE BOTTOM EDGE OF THE SMARTCAP IS CLEAN.

LOCATE BOTH RETENTION TABS ON THE REAR FLANGE AND BEND EACH TO A 45-DEGREE ANGLE FOR D-RUBBER FITMENT.

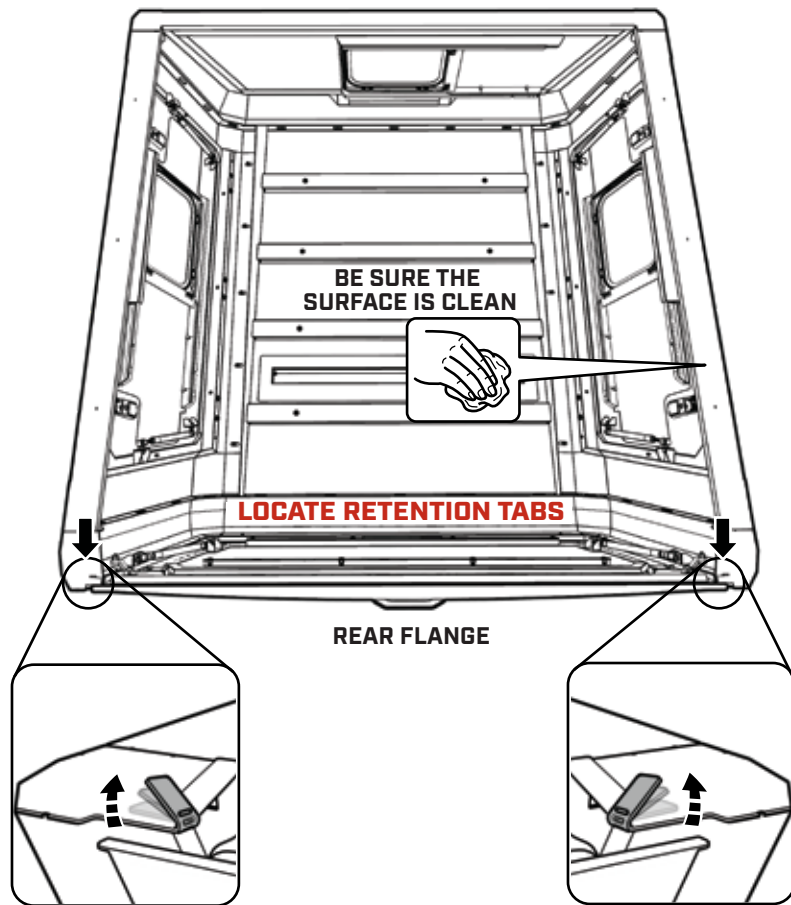

STEP 59

VW AMAROK

TRIM THE D-RUBBER WITH A CLEAN, STRAIGHT CUT.

APPLY 2-3 INCHES SUPER GLUE NEAR THE RETENTION TABS, ALONG THE BOTTOM EDGE OF THE REAR FLANGE

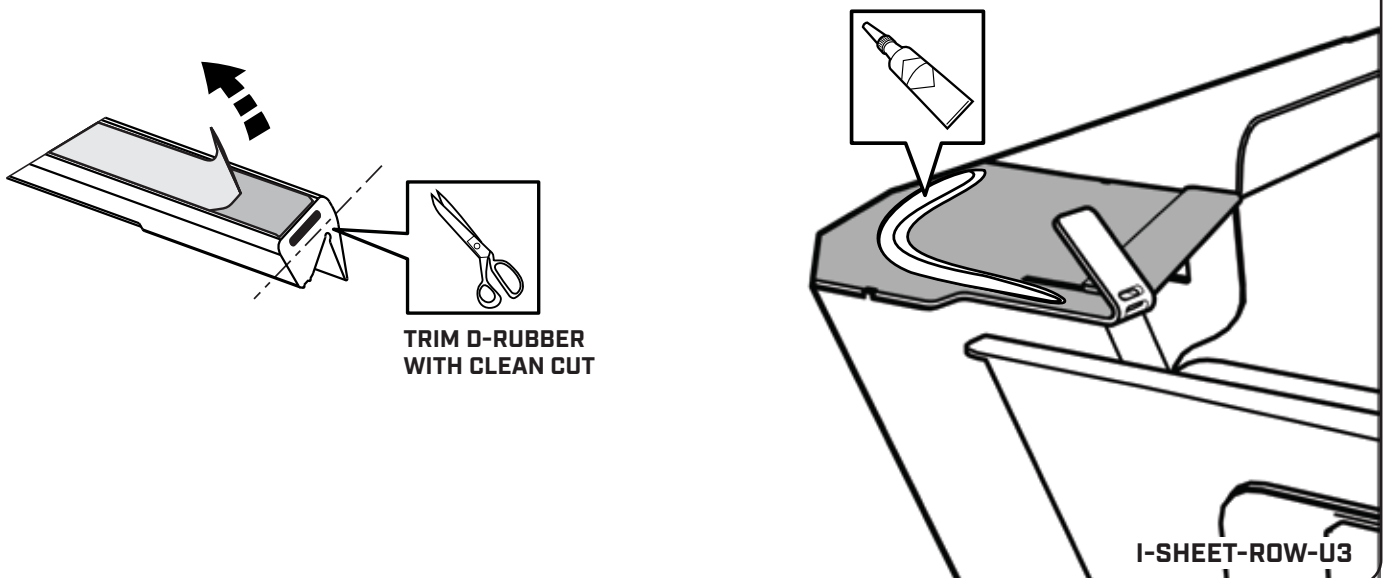
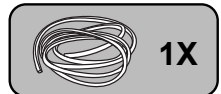

STEP 60

VW AMAROK

FULLY INSERT THE RETENTION TAB INTO THE SLOT ON THE D-RUBBER. ENSURE THE D-RUBBER IS ORIENTED CORRECTLY WITH ITS PROFILE MATCHING THE CONTOUR OF THE REAR FLANGE.

PRESS DOWN FIRMLY ON THE TAB AND THE D-RUBBER TO BOND IT TO THE REAR FLANGE, CREATING A TIGHT SEAL.

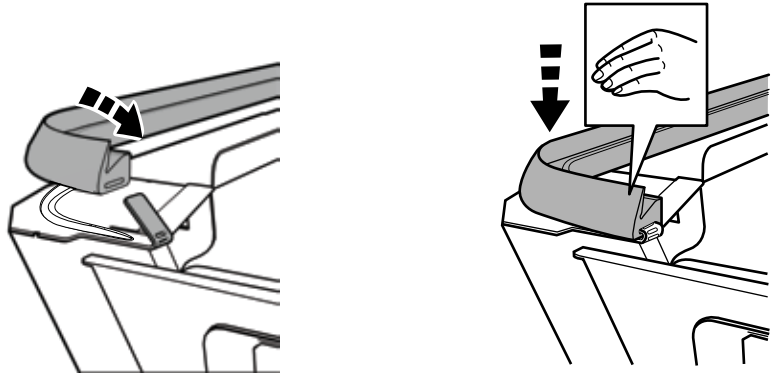

CORRECT D-RUBBER ORIENTATION

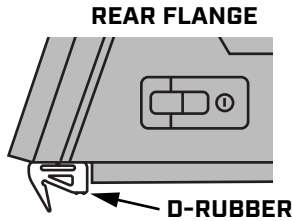

INCORRECT D-RUBBER ORIENTATION

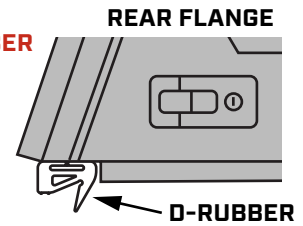

STEP 61

VW AMAROK

ALIGN THE D-RUBBER ALONG THE SMARTCAP'S EDGE, MAINTAINING A CONSISTENT 1/8 INCH GAP FROM THE EDGE.

START FROM ONE CORNER AND WORK YOUR WAY AROUND THE CAP TO ENSURE PROPER PLACEMENT AND ALIGNMENT.

REINFORCE CORNERS WITH SUPER GLUE.

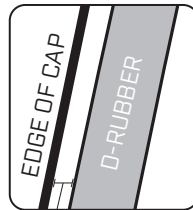

1/8 INCH FROM EDGE

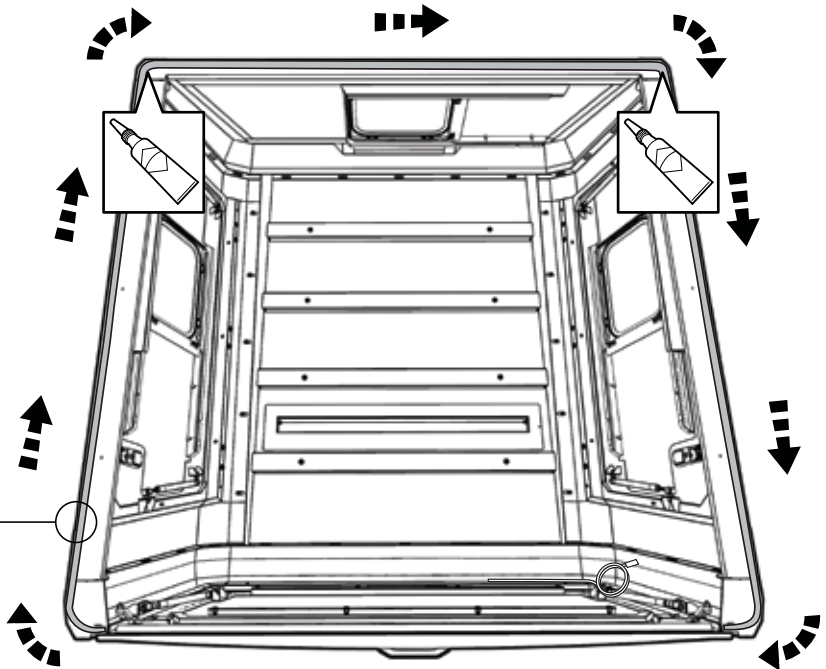

STEP 62

VW AMAROK

TRIM ANY EXCESS D-RUBBER BEYOND THE EDGE FOR A NEAT FINISH.

APPLY 2-3 INCHES OF SUPER GLUE NEAR THE RETENTION TAB, ALONG THE BOTTOM EDGE OF THE REAR FLANGE. FULLY INSERT THE RETENTION TAB INTO THE SLOT ON THE D-RUBBER.

PRESS DOWN FIRMLY ON THE TAB AND THE D-RUBBER TO BOND IT TO THE REAR FLANGE, CREATING A TIGHT SEAL.

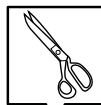

TRIM D-RUBBER WITH CLEAN CUT

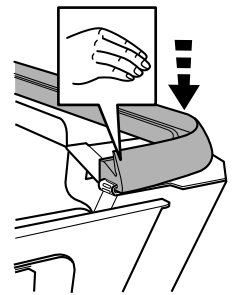
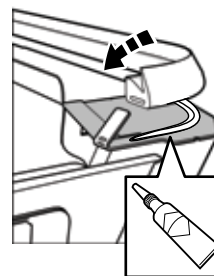
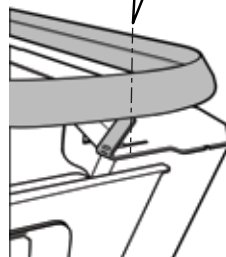

I-SHEET-ROW-U3

STEP 63

VW AMAROK

REMOVE THE FRONT TIE DOWN HOOK FROM THE OUTER WALL OF THE TRUCK BED.

HAND TIGHTEN BOTH FRONT BRACKETS TO TRUCK BED WITH M8 BOLT, M8 LOCK WASHER, TIE DOWN HOOK AND M8 FENDER WASHER AS SHOWN.

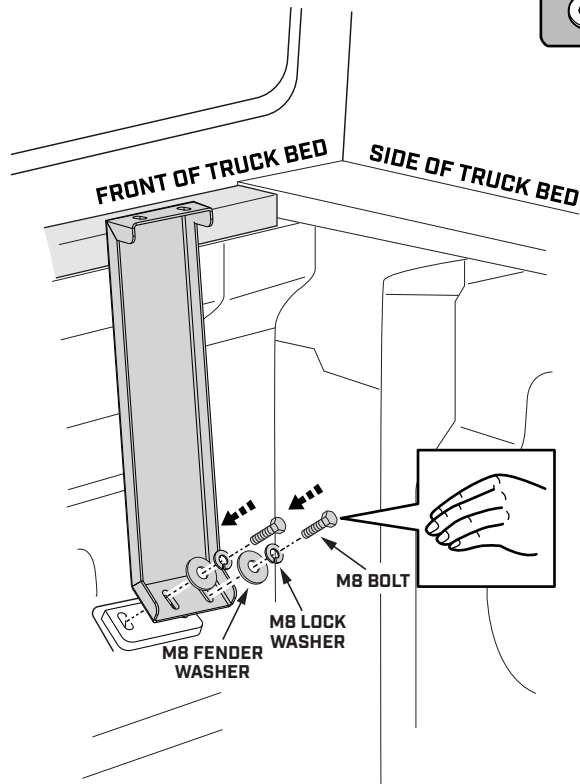
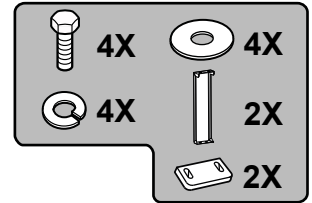

STEP 64

VW AMAROK

REMOVE THE REAR TIE DOWN HOOK FROM THE OUTER WALL OF THE TRUCK BED.

HAND TIGHTEN BOTH REAR BRACKETS TO TRUCK BED WITH M8 BOLT, M8 LOCK WASHER, TIE DOWN HOOK AND M8 FENDER WASHER AS SHOWN.

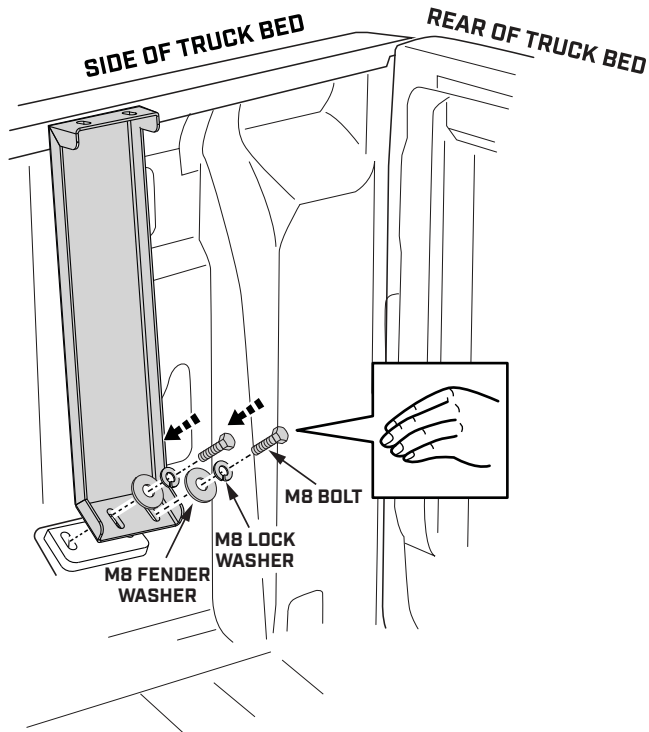
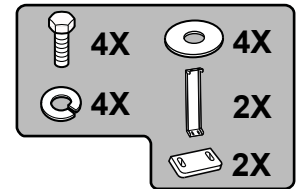

I-SHEET-ROW-U3

STEP 65

VW AMAROK

POSITION THE FRONT AND REAR MOUNTING PADS ON TOP OF MOUNTING BRACKETS AS SHOWN.

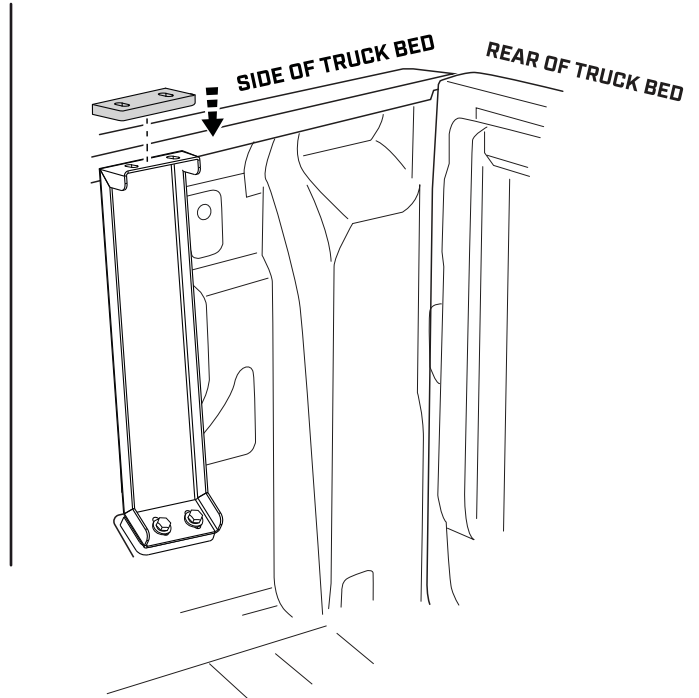
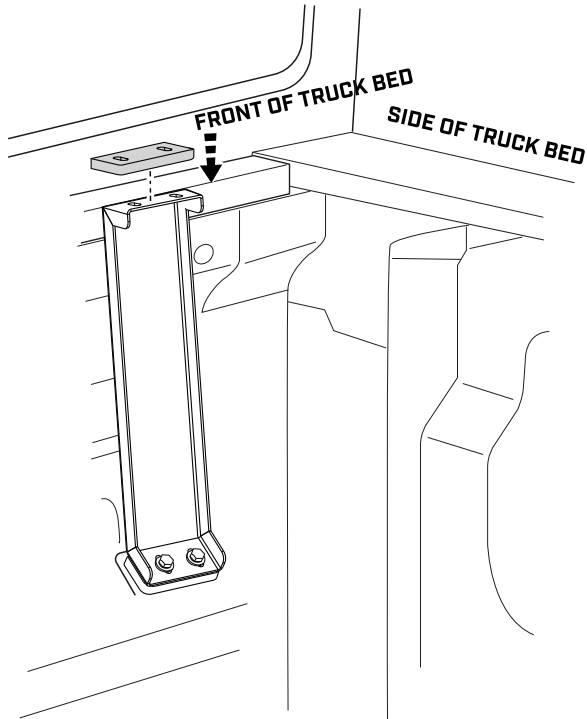
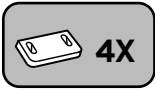

STEP 66

VW AMAROK

USE 4 PEOPLE TO LIFT THE ASSEMBLED SMARTCAP ONTO THE TRUCK BED.

TO AVOID DAMAGE TO THE D-RUBBER, DO NOT SLIDE THE SMARTCAP INTO PLACE.

4 PERSON JOB

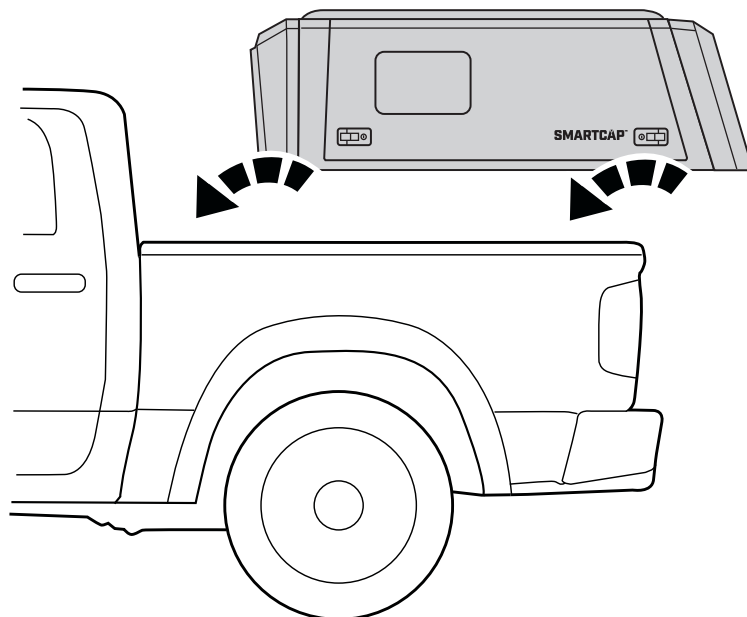

I-SHEET-ROW-U3

STEP 67

VW AMAROK

CHECK THAT THE SMARTCAP IS PROPERLY POSITIONED AND CENTERED ON THE TRUCK BED.



IT'S IMPORTANT THAT THE SMARTCAP IS NOT PUSHED TOO FAR FORWARD, LEAVING A GAP BETWEEN THE SMARTCAP AND THE CAB.

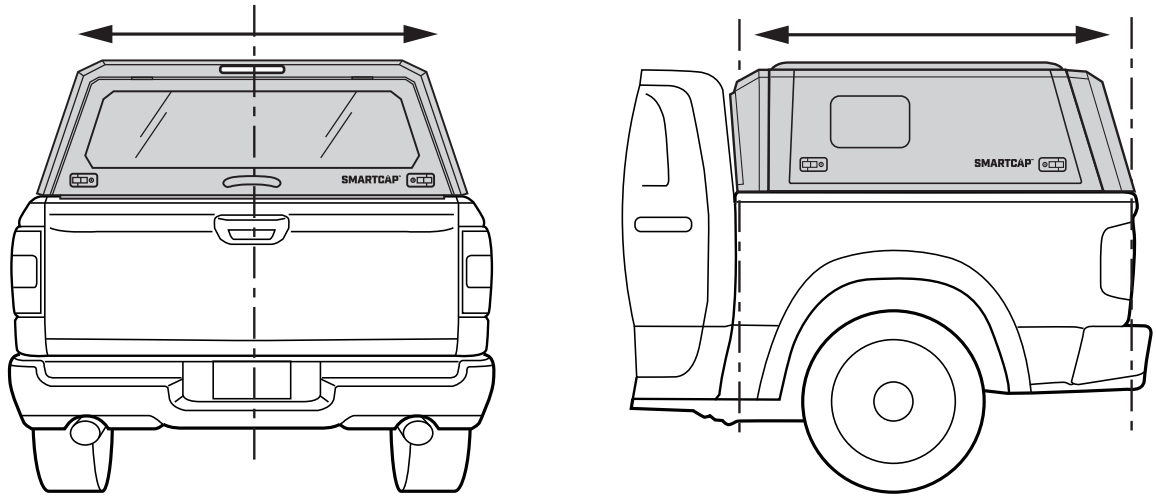

STEP 68

VW AMAROK

WALK AROUND THE TRUCK BED TO MAKE SURE THE D-RUBBER FITMENT IS CORRECT AND THAT THE RUBBER LIP IS PROPERLY TUCKED UNDERNEATH THE CAP.

CORRECT D-RUBBER ORIENTATION



D-RUBBER

REAR FLANGE

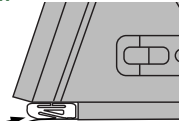

TAILGATE

INCORRECT D-RUBBER ORIENTATION



D-RUBBER

REAR FLANGE



TAILGATE

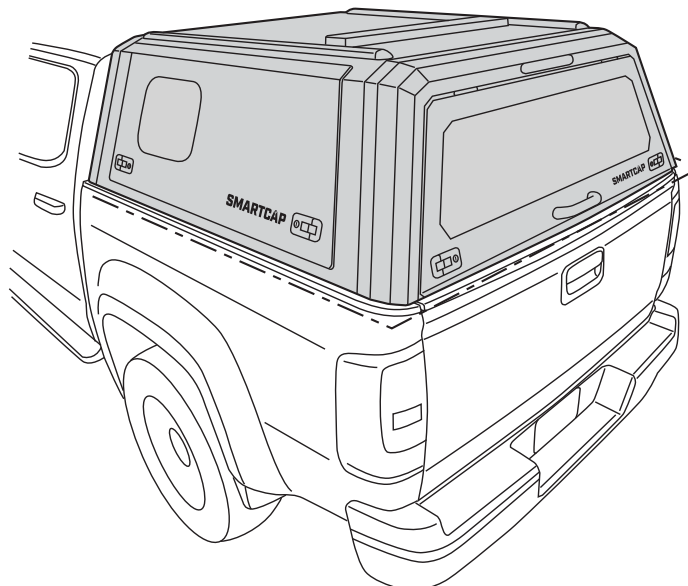

I-SHEET-ROW-U3

STEP 69

VW AMAROK

SECURE BOTH FRONT BRACKETS TO THE SMARTCAP WITH M8 BOLTS, M8 FENDER WASHER AND M8 LOCK NUT AS SHOWN, HAND TIGHTEN ONLY.

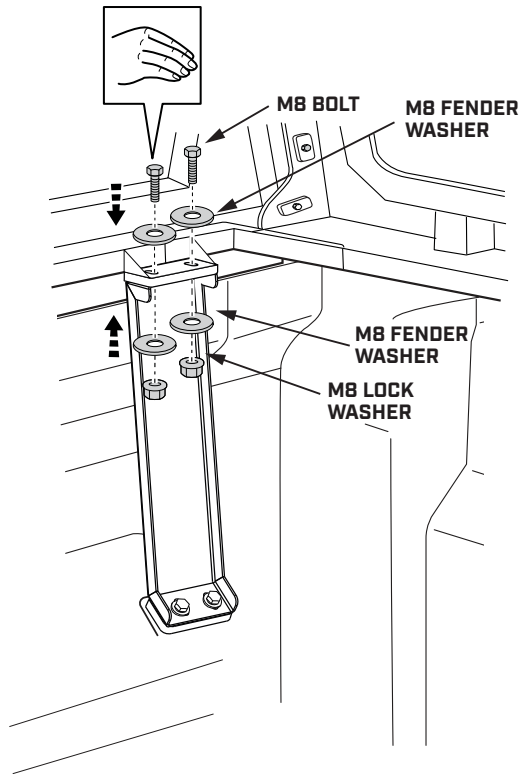

STEP 70

VW AMAROK

SECURE BOTH REAR BRACKETS TO THE SMARTCAP USING M8 BOLTS, M8 FENDER WASHERS AND M8 LOCK NUT AS SHOWN, HAND TIGHTEN ONLY.

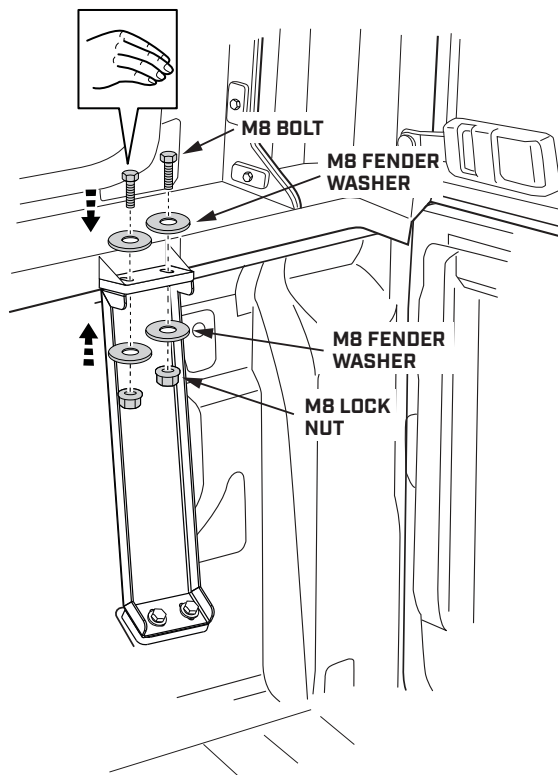

I-SHEET-ROW-U2

STEP 71

VW AMAROK

TIGHTEN FASTENERS FOR BOTH FRONT MOUNTING BRACKETS USING THE TORQUE WRENCH AND 13MM SOCKET TO 4.4 FT. LBS. [6NM]

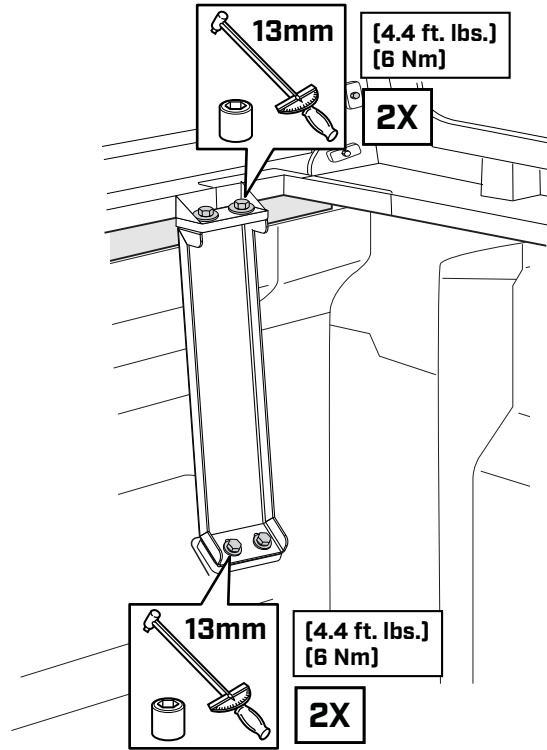

STEP 72

VW AMAROK

TIGHTEN FASTENERS FOR BOTH REAR MOUNTING BRACKETS USING THE TORQUE WRENCH AND 13MM SOCKET TO 4.4 FT. LBS. [6NM]

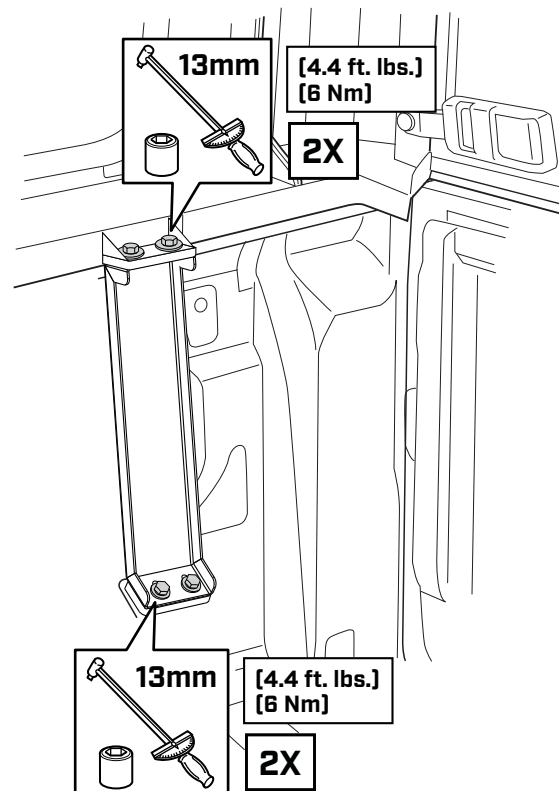

STEP 73

LAND CRUISER

INSPECT THE TRUCK BED.

ADD 3-4 STRIPS OF FOAM SEAL TAPE ON TOP OF EACH OTHER TO THE FRONT EDGE OF THE TRUCK BED.

CUT TO LENGTH NEEDED.

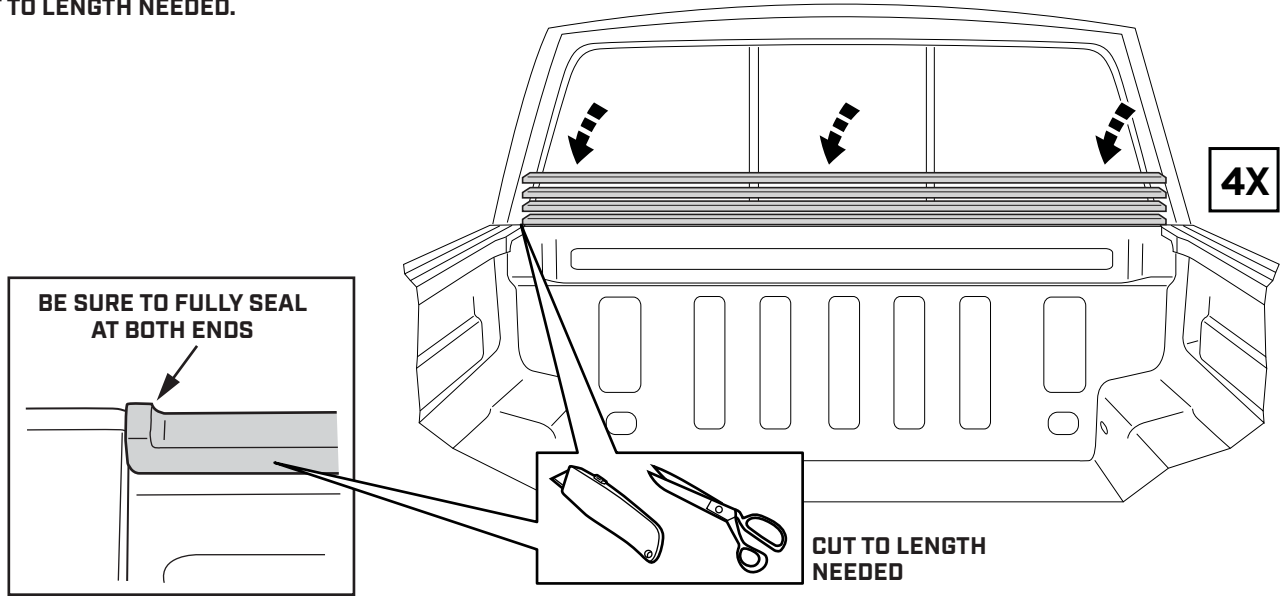
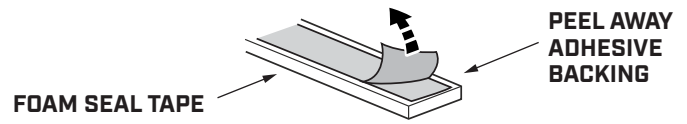

STEP 74

LAND CRUISER

ENSURE THE ENTIRE BOTTOM EDGE OF THE SMARTCAP IS CLEAN.

LOCATE BOTH RETENTION TABS ON THE REAR FLANGE AND BEND EACH TO A 45-DEGREE ANGLE FOR D-RUBBER FITMENT.

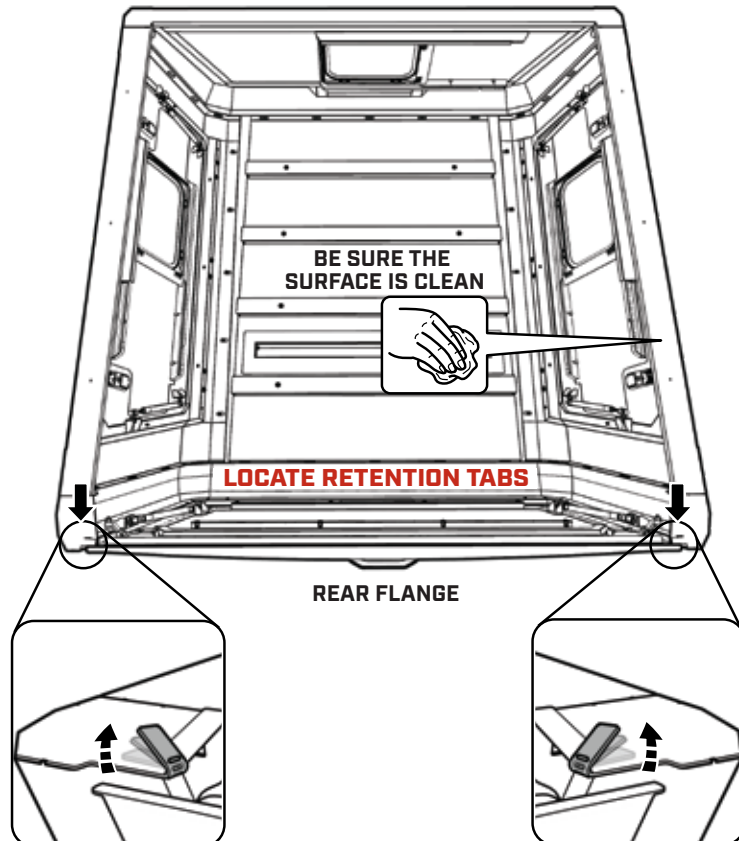

I-SHEET-ROW-U3

STEP 75

LAND CRUISER

TRIM THE D-RUBBER WITH A CLEAN, STRAIGHT CUT.

APPLY 2-3 INCHES SUPER GLUE NEAR THE RETENTION TABS, ALONG THE BOTTOM EDGE OF THE REAR FLANGE

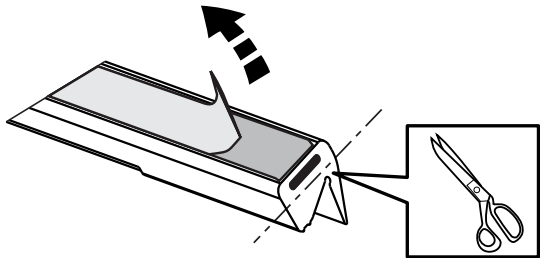

TRIM D-RUBBER WITH CLEAN CUT

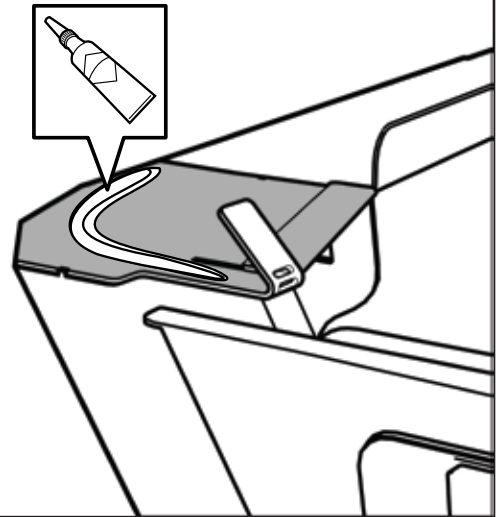

STEP 76

LAND CRUISER

FULLY INSERT THE RETENTION TAB INTO THE SLOT ON THE D-RUBBER. ENSURE THE D-RUBBER IS ORIENTED CORRECTLY WITH ITS PROFILE MATCHING THE CONTOUR OF THE REAR FLANGE.

PRESS DOWN FIRMLY ON THE TAB AND THE D-RUBBER TO BOND IT TO THE REAR FLANGE, CREATING A TIGHT SEAL.

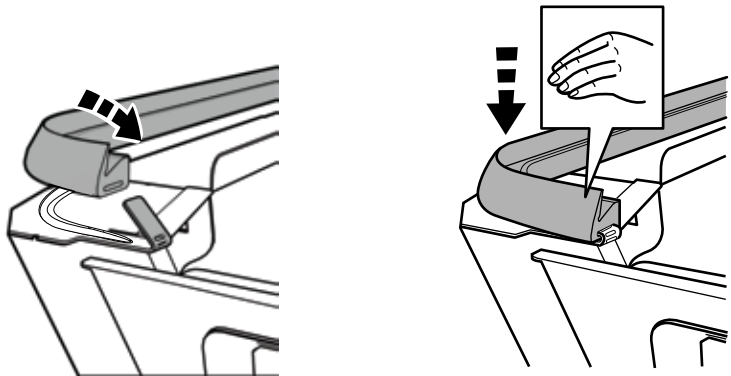

CORRECT D-RUBBER ORIENTATION

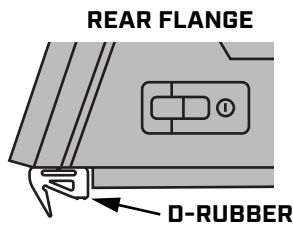

INCORRECT D-RUBBER ORIENTATION

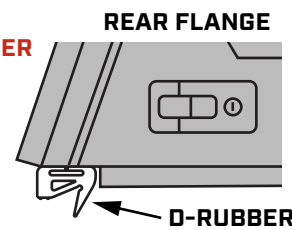

STEP 77

LAND CRUISER

ALIGN THE D-RUBBER ALONG THE SMARTCAP'S EDGE, MAINTAINING A CONSISTENT 1/8 INCH GAP FROM THE EDGE.

START FROM ONE CORNER AND WORK YOUR WAY AROUND THE CAP TO ENSURE PROPER PLACEMENT AND ALIGNMENT.

REPEAT PROCESS FOR OPPOSITE SIDE.

REINFORCE CORNERS WITH SUPER GLUE.

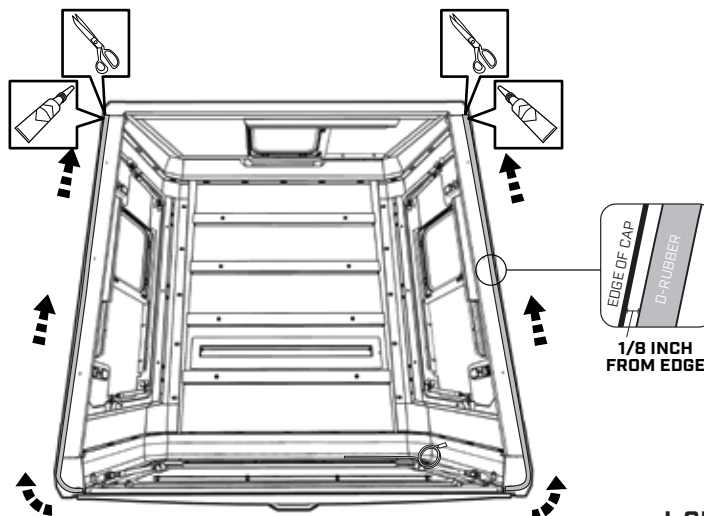

I-SHEET-ROW-U3

STEP 78

LAND CRUISER

PLACE DRILL JIG FLUSH WITH SIDE EDGE AND FRONT EDGE OF TRUCK BED FOR CORRECT DRILLING POSITION.

MARK HOLE POSITIONS WITH DRILL JIG IN PLACE.

REPEAT FOR OPPOSITE SIDE.

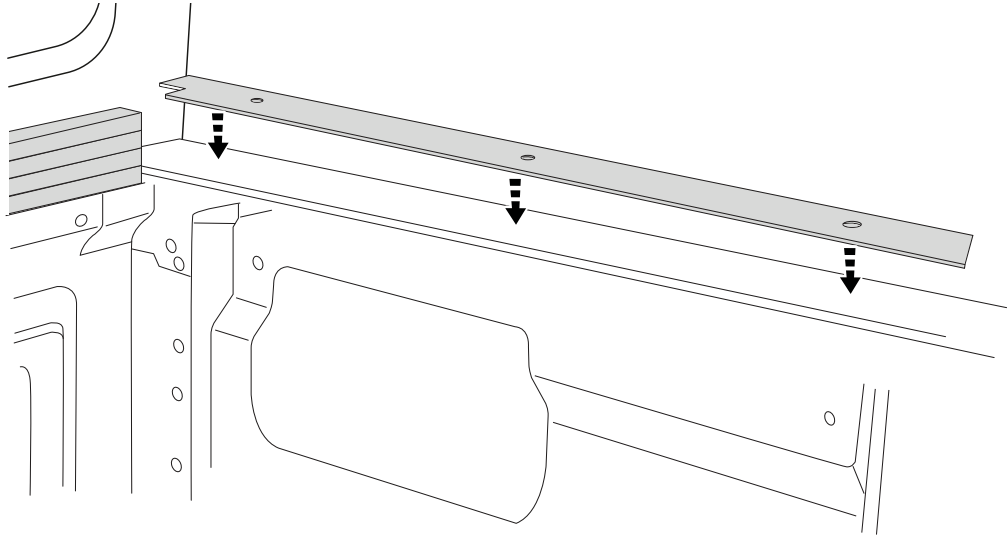

STEP 79

LAND CRUISER

USING A 1/2" DRILL BIT, DRILL OUT ALL MARKED LOCATIONS ALONG THE TRUCK BED.

REPEAT FOR OPPOSITE SIDE.

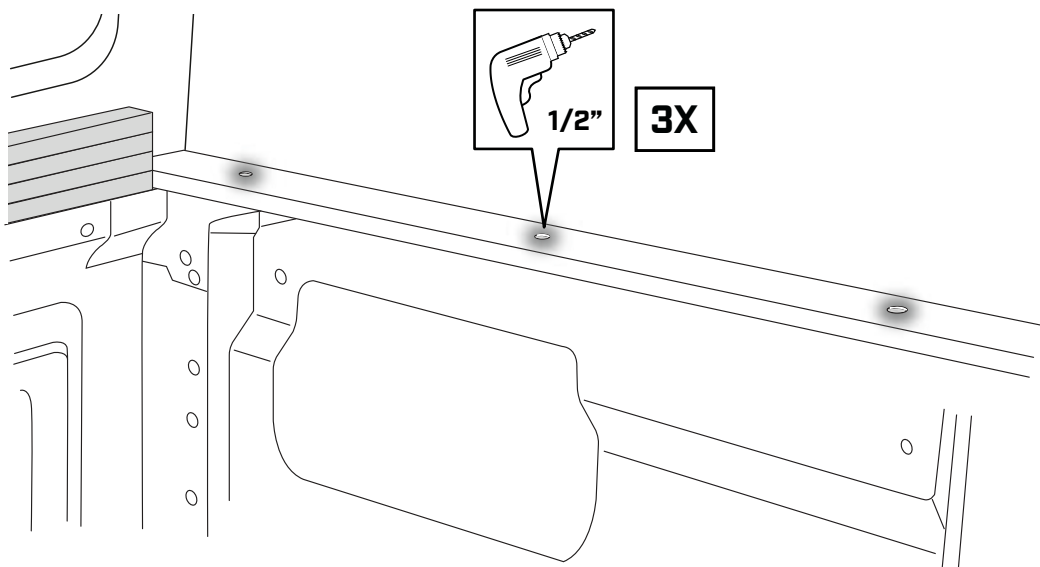

I-SHEET-ROW-U3

STEP 80

LAND CRUISER

USE 4 PEOPLE TO LIFT THE ASSEMBLED SMARTCAP ONTO THE TRUCK BED.

TO AVOID DAMAGE TO THE D-RUBBER, DO NOT SLIDE THE SMARTCAP INTO PLACE.

4 PERSON JOB

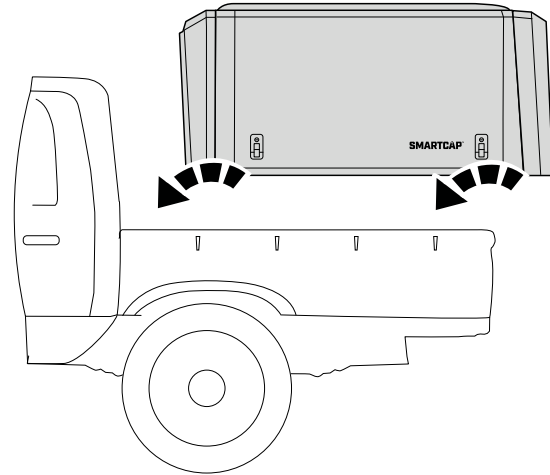

STEP 81

LAND CRUISER

CHECK THAT THE SMARTCAP IS PROPERLY POSITIONED AND CENTERED ON THE TRUCK BED.

IT'S IMPORTANT THAT THE SMARTCAP IS NOT PUSHED TOO FAR FORWARD, LEAVING A GAP BETWEEN THE SMARTCAP AND THE CAB.

4 PERSON JOB

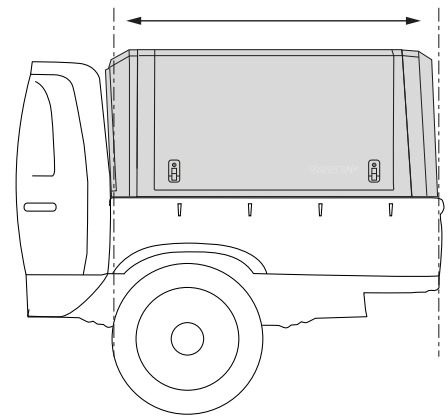
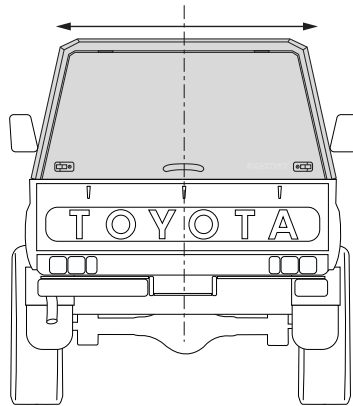

STEP 82

LAND CRUISER

WALK AROUND THE TRUCK BED TO MAKE SURE THE D-RUBBER FITMENT IS CORRECT AND THAT THE RUBBER LIP IS PROPERLY TUCKED UNDERNEATH THE CAP.

CORRECT D-RUBBER ORIENTATION

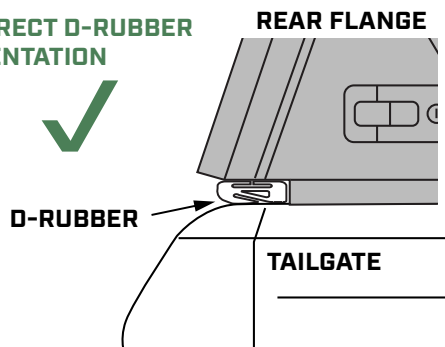

INCORRECT D-RUBBER ORIENTATION

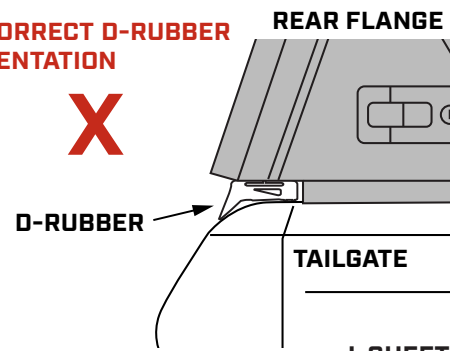

I-SHEET-ROW-U3

STEP 83

LAND CRUISER

MOUNT THE SMARTCAP USING M8 BOLTS, M8 FENDER WASHERS AND M8 LOCK NUT AS SHOWN, HAND TIGHTEN ONLY.

REPEAT FOR OPPOSITE SIDE.

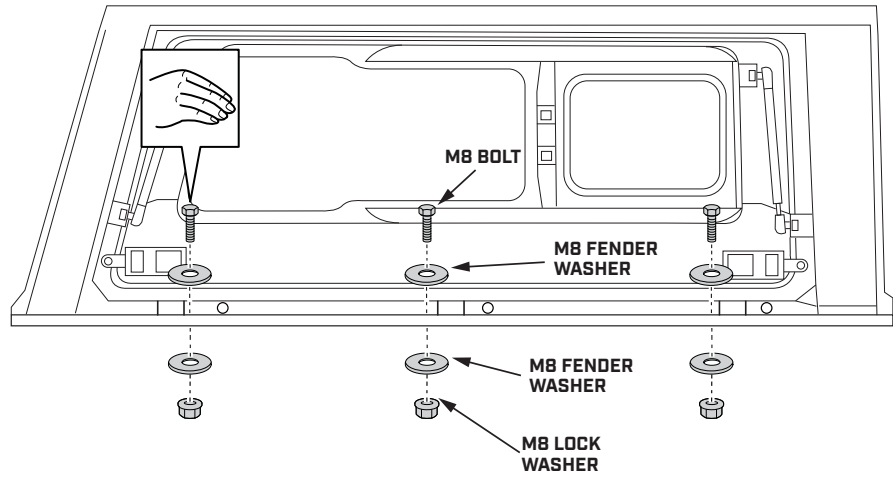
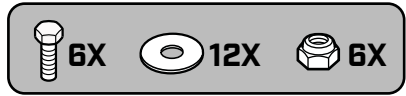

STEP 84

LAND CRUISER

TIGHTEN FASTENERS FOR BOTH SIDES USING A TORQUE WRENCH AND 13MM SOCKET TO 4.4 FT. LBS. [6 NM]

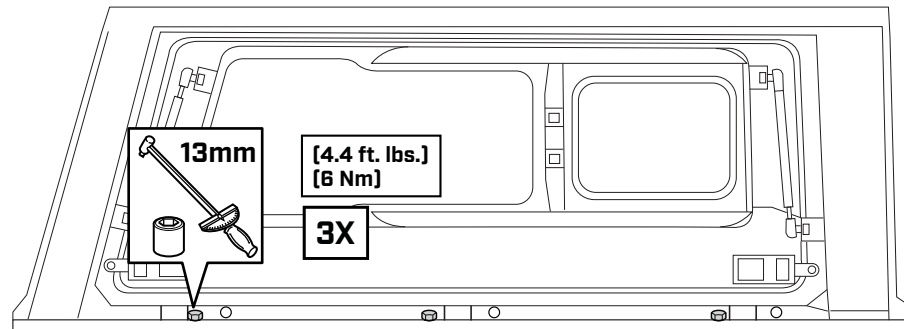

STEP 85

LAND CRUISER

INSERT PLASTIC END CAPS ALONG THE INSIDE OF THE SMARTCAP.

REPEAT FOR OPPOSITE SIDE.

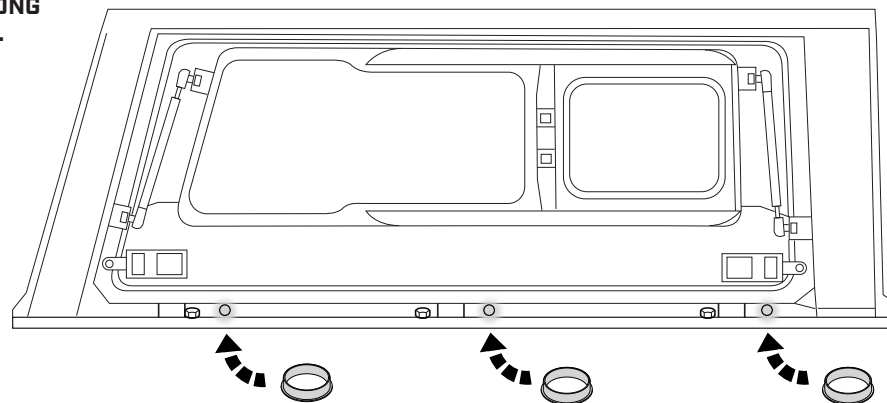

I-SHEET-ROW-U3

THIRD BRAKE LIGHT HARDWARE

T-HARNESS

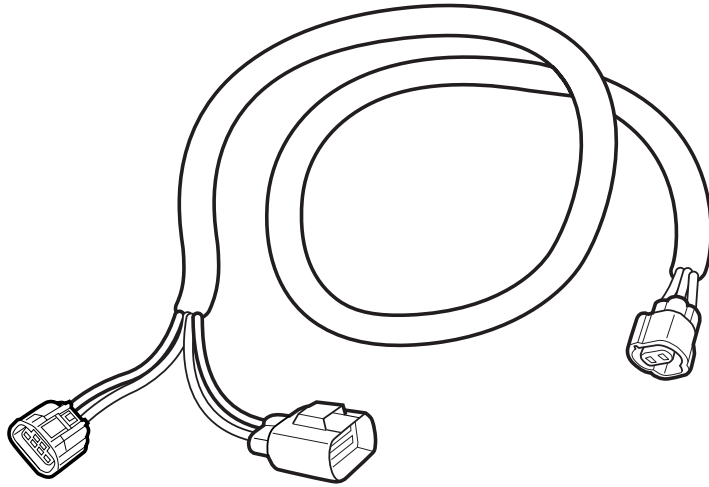

1X



IMPORTANT

- ▼ BE SURE THE VEHICLE IS TURNED OFF FOR THIS INSTALLATION.
- ▼ READ THROUGH THE ENTIRE PROCEDURE BEFORE STARTING AND FOLLOW THE STEPS CAREFULLY TO ENSURE THE THIRD BRAKE LIGHT WILL FUNCTION PROPERLY.
- ▼ USE A TEST LIGHT TO CHECK FOR SUCCESSFUL INSTALLATION.

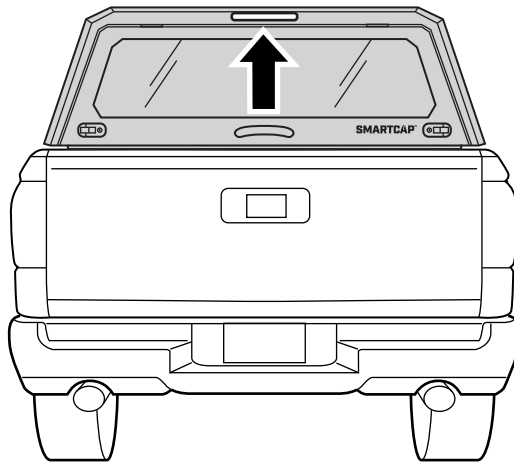

I-SHEET-ROW-U3

STEP 86

REMOVE THE BOLTS HOLDING THE DRIVER SIDE TAILLIGHT ASSEMBLY.

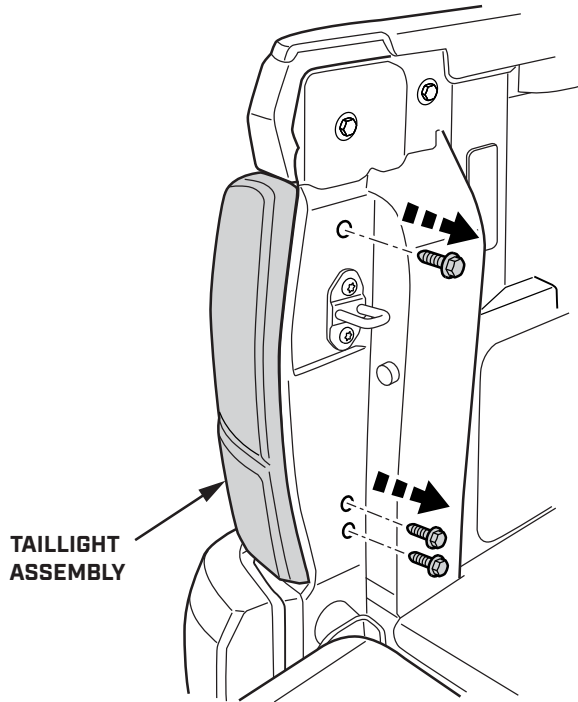

PLACE THE TAILLIGHT ASSEMBLY CAREFULLY ON THE TAILGATE. DO NOT UNPLUG ANY CONNECTORS.

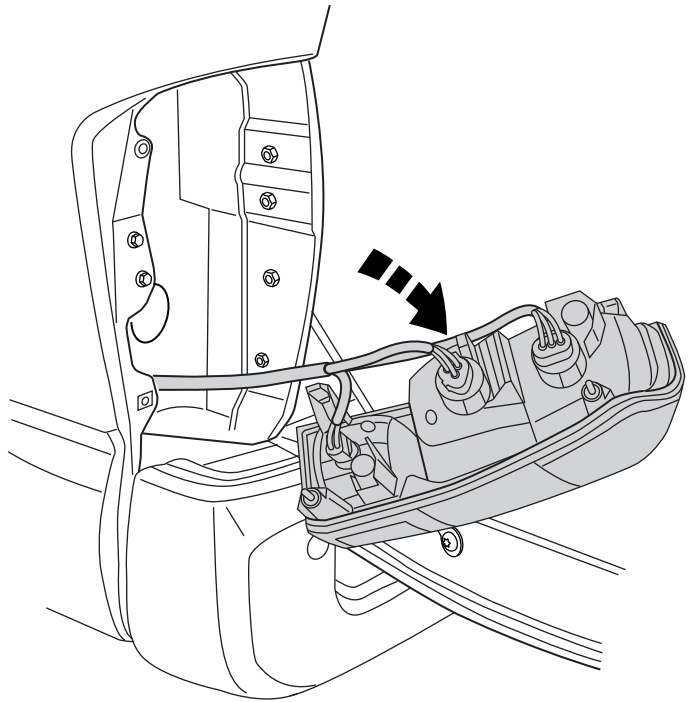

STEP 87

UNTIE THE THIRD BRAKE LIGHT HARNESS FROM WHERE IT IS ATTACHED TO THE SMARTCAP.

REMOVE THE GROMMET COVER AT THE TRUCK BED WALL.

ROUTE THE THIRD BRAKE LIGHT HARNESS IN THROUGH THE GROMMET PANEL OPENING AND OUT THROUGH THE TAILLIGHT CAVITY.

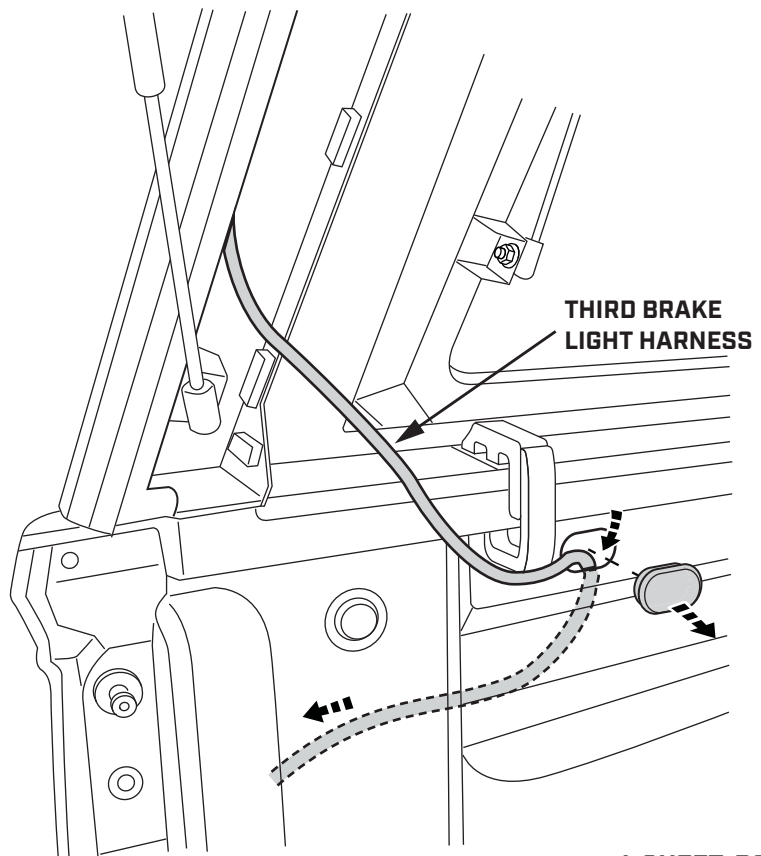

I-SHEET-ROW-U3

STEP 88

DISCONNECT THE MIDDLE BRAKE LIGHT PLUG AT THE BACK OF THE TAILLIGHT ASSEMBLY.

TAILLIGHT CAVITY

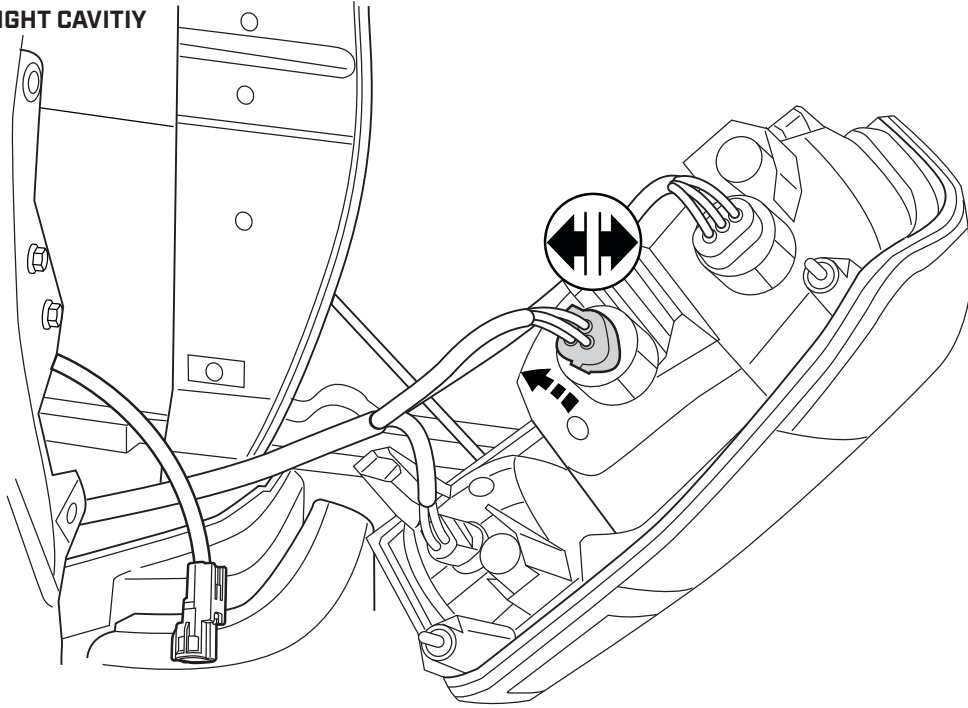

STEP 89

CONNECT THE FEMALE PLUG FROM THE T-HARNESS INTO THE MALE BRAKE LIGHT SOCKET.

CONNECT THE MALE PLUG FROM THE T-HARNESS INTO THE FEMALE BRAKE LIGHT SOCKET.

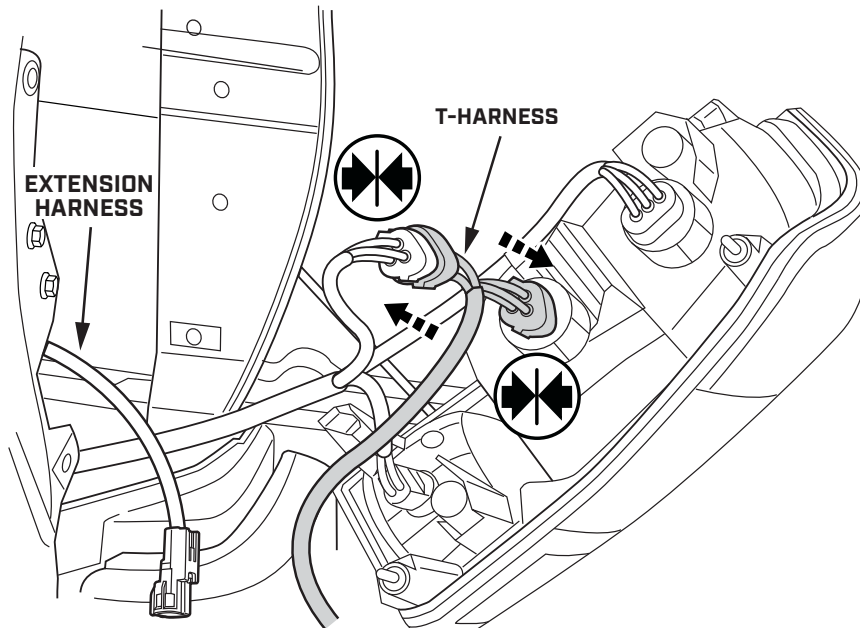

I-SHEET-ROW-U3

STEP 90

CONNECT THE T-HARNESS TO THE EXTENSION HARNESS.

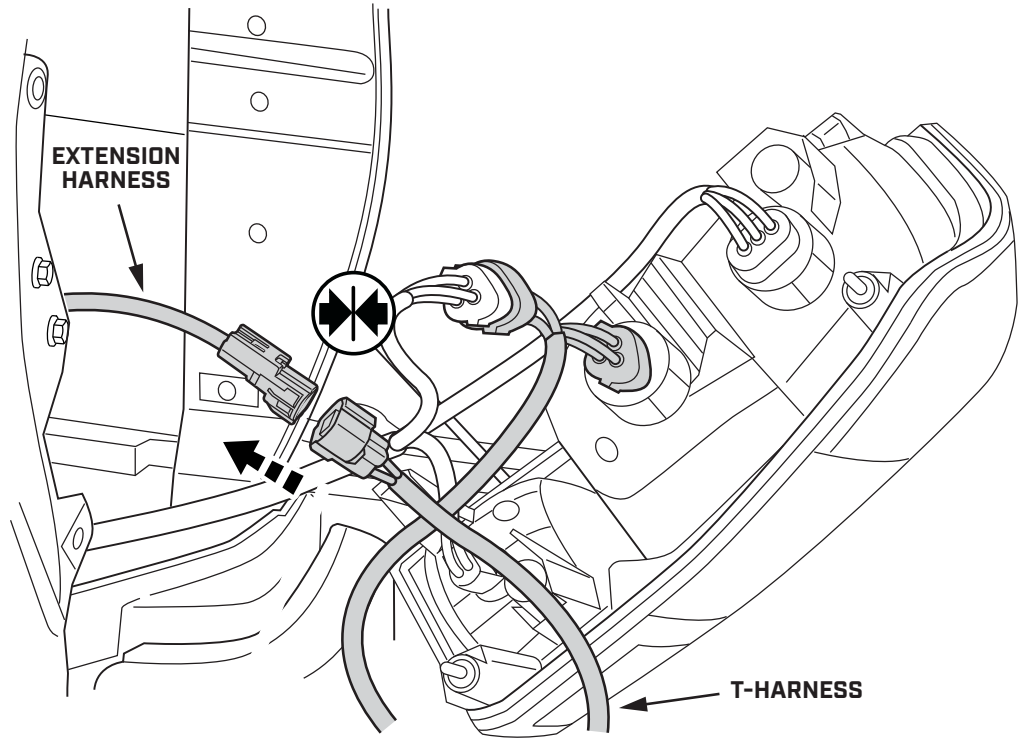

STEP 91

BUNDLE EXTRA T-HARNESS LENGTH IN THE TAILLIGHT CAVITY AND SECURE WITH CABLE TIES.

REINSTALL THE TAILLIGHT ASSEMBLY.

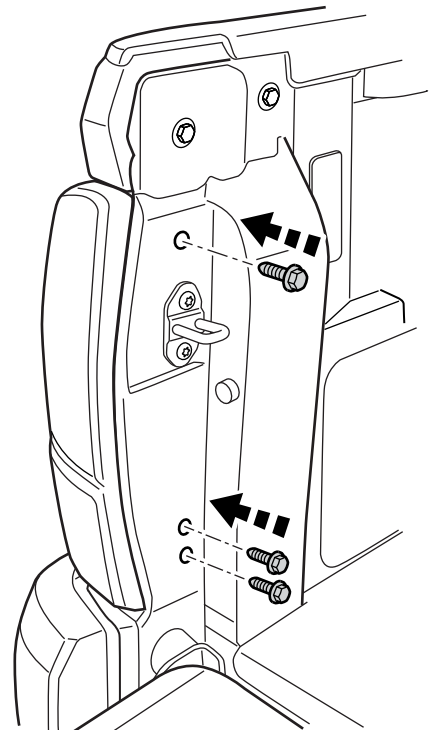
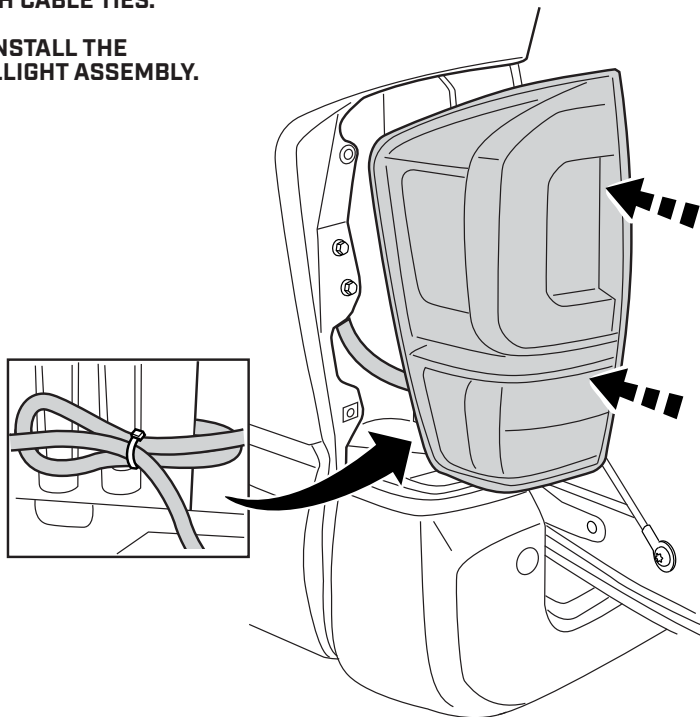

STEP 92



TEST YOUR BRAKE LIGHTS & TURN SIGNALS

- ▼ START THE TRUCK. SOME MODELS MAY TAKE UP TO 30 SECONDS FOR THE VEHICLE TO DETECT THE NEW CONNECTION.
- ▼ CHECK THE BRAKE LIGHTS AND TURN SIGNALS TO BE SURE THEY ARE FUNCTIONING PROPERLY.
- ▼ ONCE YOU HAVE CONFIRMED THAT THE LIGHTS ARE WORKING CORRECTLY, SECURE THE HARNESS WITH CABLE TIES.
- ▼ BE SURE NOT TO INTERFERE WITH ANY MOVING PARTS ON THE VEHICLE.



THANKS FOR YOUR PURCHASE.
PLEASE LET US KNOW IF YOU HAVE ANY QUESTIONS.

SMARTCAP.COM
SUPPORT.NA@SMARTCAP.COM - NORTH AMERICA
SUPPORT.SA@SMARTCAP.COM - REST OF WORLD

