

SMARTCAP®

EVO, EVOa, EVOc & EVOd Series

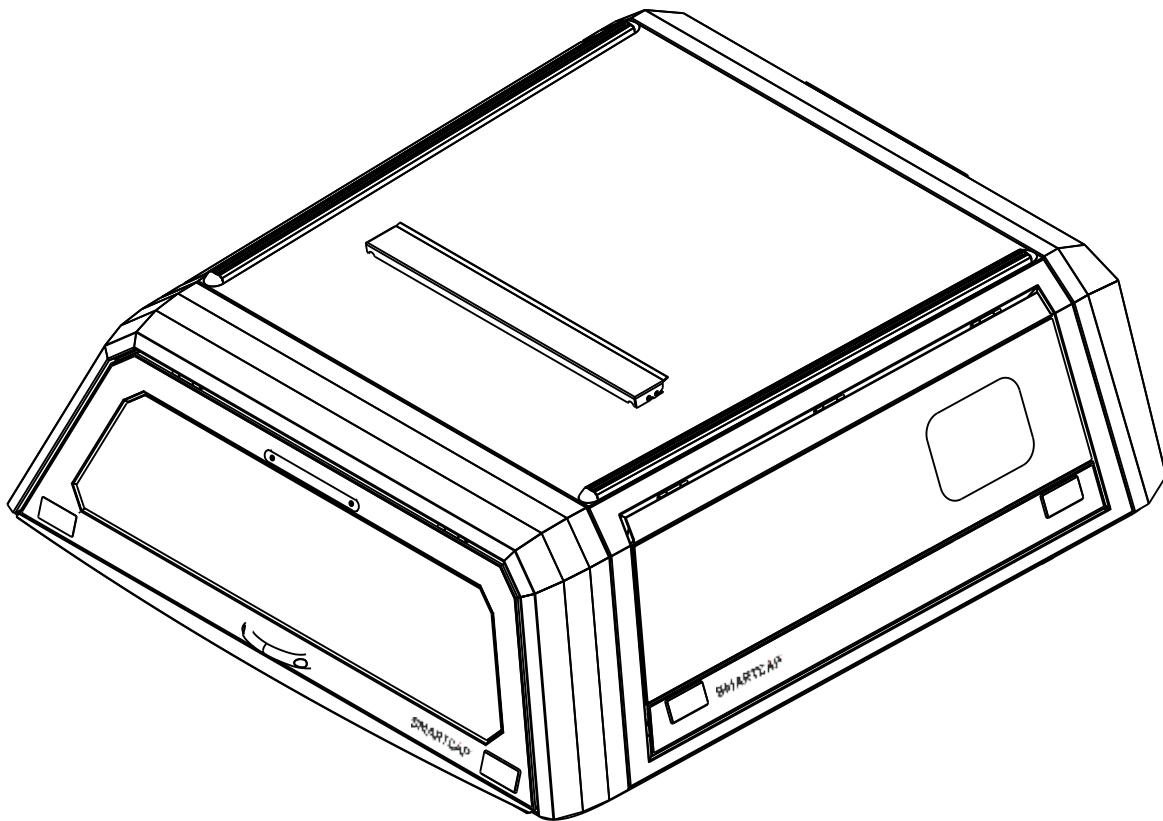

TO ENSURE YOU ARE USING THE MOST RECENT VERSION, PLEASE DOWNLOAD THE INSTRUCTION GUIDE AT WWW.SA.RSISMARTCAP.COM/ASSEMBLY-FITMENT FOLLOW INSTRUCTIONS CAREFULLY TO AVOID DAMAGE TO COMPONENTS OR THE VEHICLE

RSISMARTCAP.COM - SUPPORT.SA@RSISMARTCAP.COM - REST OF WORLD



TABLE OF CONTENTS

REQUIRED TOOLS	2
ASSEMBLY INSTRUCTIONS	3
Unboxing Instructions	3
Components & Assembly Hardware	4
Assembly of the SmartCap	6
INSTALLATION INSTRUCTIONS	15
Fitment Kit Contents	15
Installation of the SmartCap	16
Ford Ranger	17
Toyota Hilux	19
VW Amarok	23
Isuzu D-Max	24
Mitsubishi Triton	25
Toyota Land Cruiser	26
THIRD BRAKE LIGHT WIRING HARNESS	27
Ford Ranger, Toyota Hilux, VW Amarok, Isuzu D-Max	27
Wiring Reference Guide	28
Wiring Reference Guide	29
NOTES	30
SUPPORT DETAILS	31

REQUIRED TOOLS

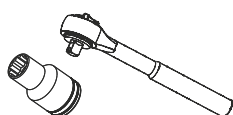

Socket Wrench
10mm & 13mm Socket

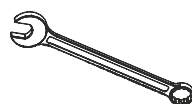

Combination Wrench
10mm & 13mm Flat

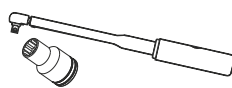

Torque Wrench
10mm & 13mm Flat



Sharp Box Knife
Or Scissors



Super Glue

WARNING



- **USE ONLY THE TOOLS RECOMMENDED IN THIS GUIDE**
- **USE ONLY THE HARDWARE THAT HAS BEEN PROVIDED**
- **HANDLE ALL COMPONENTS WITH CARE**
- **IT IS RECOMMENDED THAT FOUR PEOPLE LIFT/LOWER THE SMARTCAP**
- **NEVER USE ACETONE ON THE PAINTWORK**
- **AVOID PINCHING/SQUASHING HANDS**

UNBOXING INSTRUCTIONS

1. INSPECT THE ENTIRE PACKAGE FOR DAMAGE. IF ANY IS FOUND, CONTACT: SUPPORT.SA@RSISMARTCAP.COM
2. ENSURE THE WORK AREA IS CLEAN BEFORE UNBOXING.
3. ENSURE THE REQUIRED TOOLS ARE PRESENT AND ALL HARDWARE CONTENTS ARE ACCOUNTED FOR.
4. WE RECOMMEND A MINIMUM OF 2 PEOPLE TO UNBOX THE PACKAGED CONTENT.
5. UNSTRAP THE BOXES.
6. ORIENT THE ROOF PANEL BOX WITH THE "THIS SIDE UP" LABEL FACING UPWARDS.

NOTE: ENSURE ALL PANELS ARE CORRECTLY ORIENTATED (THIS SIDE UP). USE STRAPS TO HELP LIFT THE BOXES

UNBOXING EXPLODED VIEW

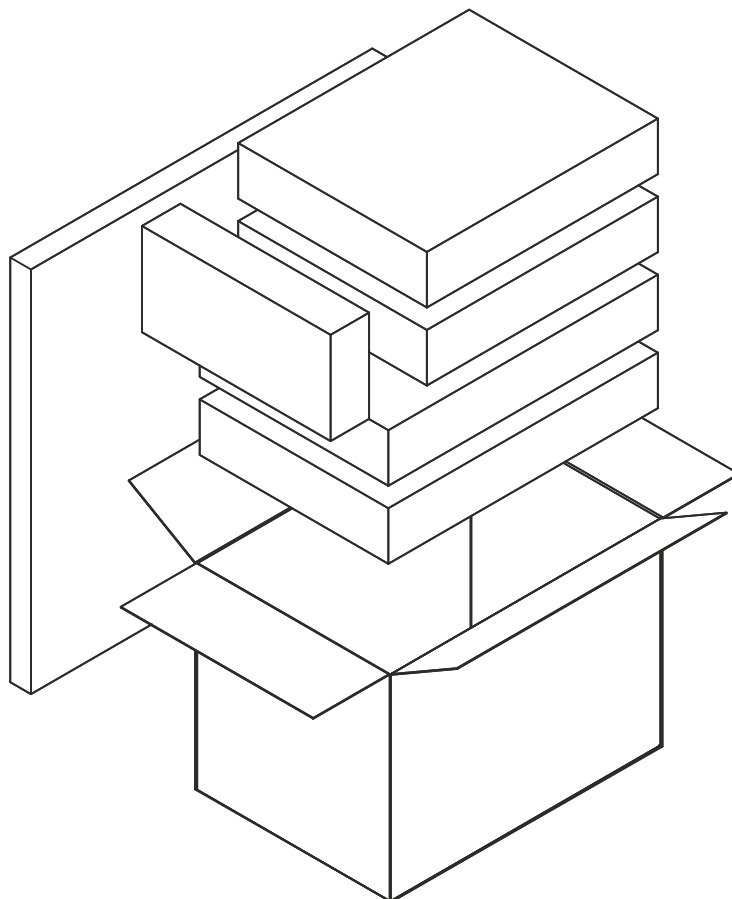

COMPONENTS

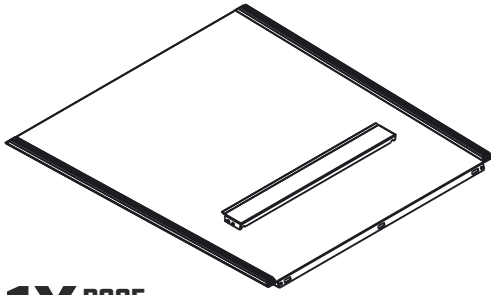

1X ROOF PANEL

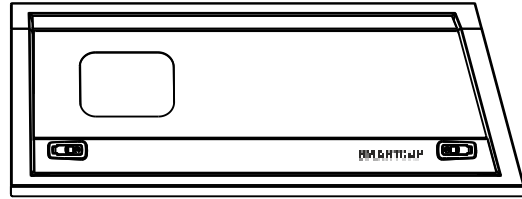

2X SIDE PANELS LEFT & RIGHT

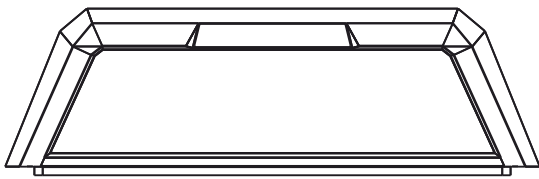

1X FRONT FLANGE

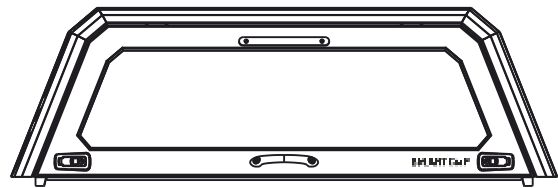

1X REAR FLANGE

ASSEMBLY HARDWARE

FASTENER BLOCKS



IMPORTANT

▼ DETERMINE WHICH VERSION YOUR FITMENT KIT CONTAINS. (VERSION A OR VERSION B)

[PRE-FASTENED TO FLANGES]

VERSION A

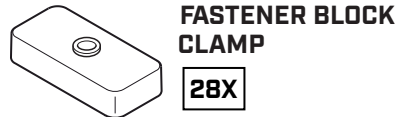
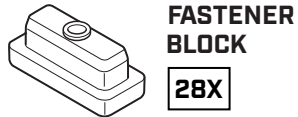

VERSION B

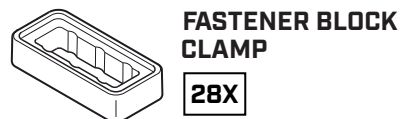
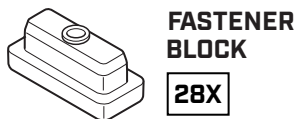

ASSEMBLY KIT CONTENTS

KIT 1: ROOF PANEL FASTENING HARDWARE

**DOUBLE CAB
FOR ALL DC**



10X M6 NYLOC NUTS

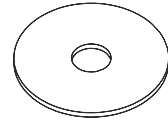

10X M6X25 FENDER WASHERS

**EXTENDED CAB
FOR ALL EC**



12X M6 NYLOC NUTS

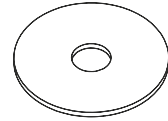

12X M6X25 FENDER WASHERS

WEATHER SEAL



IMPORTANT

▼ DETERMINE WHICH VERSION YOUR FITMENT KIT CONTAINS. (VERSION A OR VERSION B)

D-RUBBER

1X

VERSION A

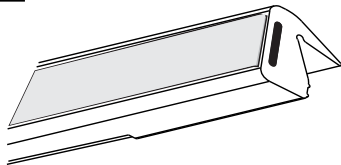

VERSION B

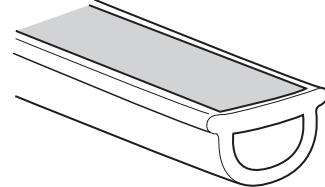

KIT 2: SPARE PART

SPARE HARDWARE

1X

VERSION A

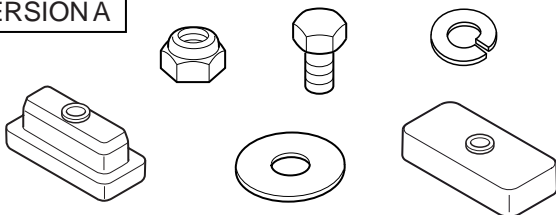

VERSION B

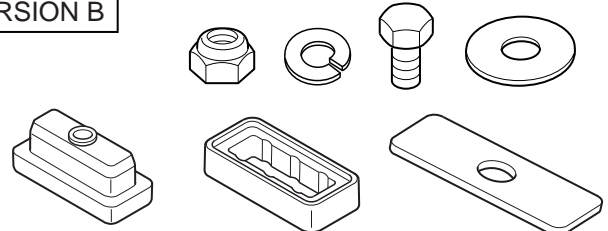

ASSEMBLY OF THE CAP

ASSEMBLY EXPLODED VIEW

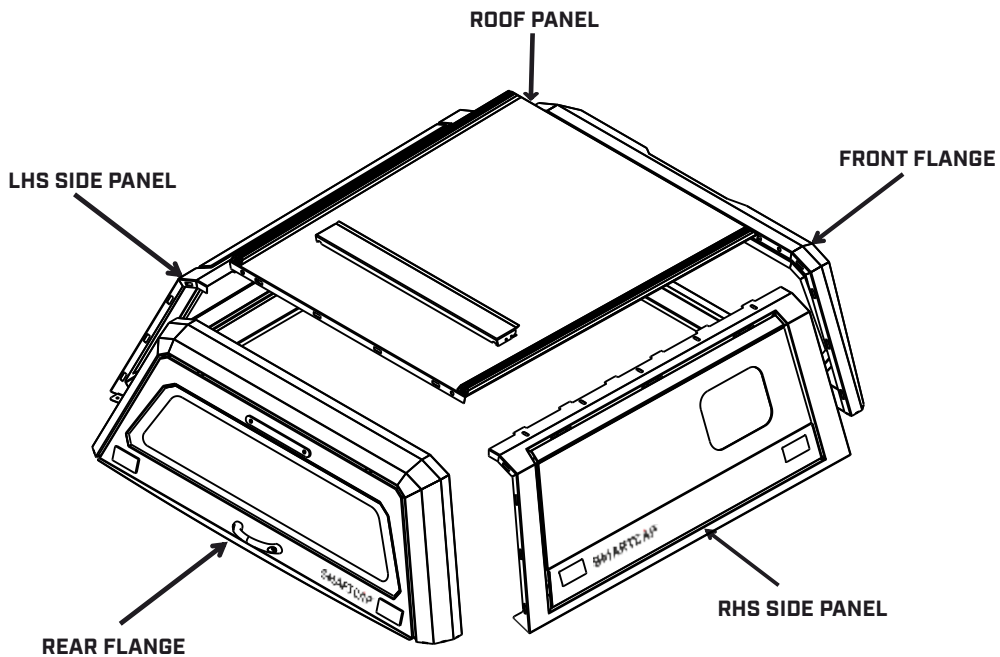

STEP ONE

1. ORIENT THE ROOF PANEL BOX WITH "THIS SIDE UP" LABEL FACING UPWARDS, THEN OPEN.
2. UNFOLD THE PROTECTIVE PLASTIC SHEET, LEAVING IT ON THE BOTTOM OF THE ROOF PANEL.
3. USE THE OPEN BOX LID AS A PROTECTIVE SURFACE TO ASSEMBLE THE SMARTCAP UPON.
[SEE FIGURE 1]
4. WORK WITH CAUTION TO PREVENT ANY DAMAGE.
5. REMOVE THE FOUR NUTS AND WASHERS ON THE INTERNAL SIDE OF THE ROOF THAT IS HOLDING THE TWO ROOF RAILS IN PLACE. THESE ARE IN PLACE TO AID TRANSPORTATION AND SHOULD BE REMOVED AND DISCARDED OF [SEE FIGURE 1]

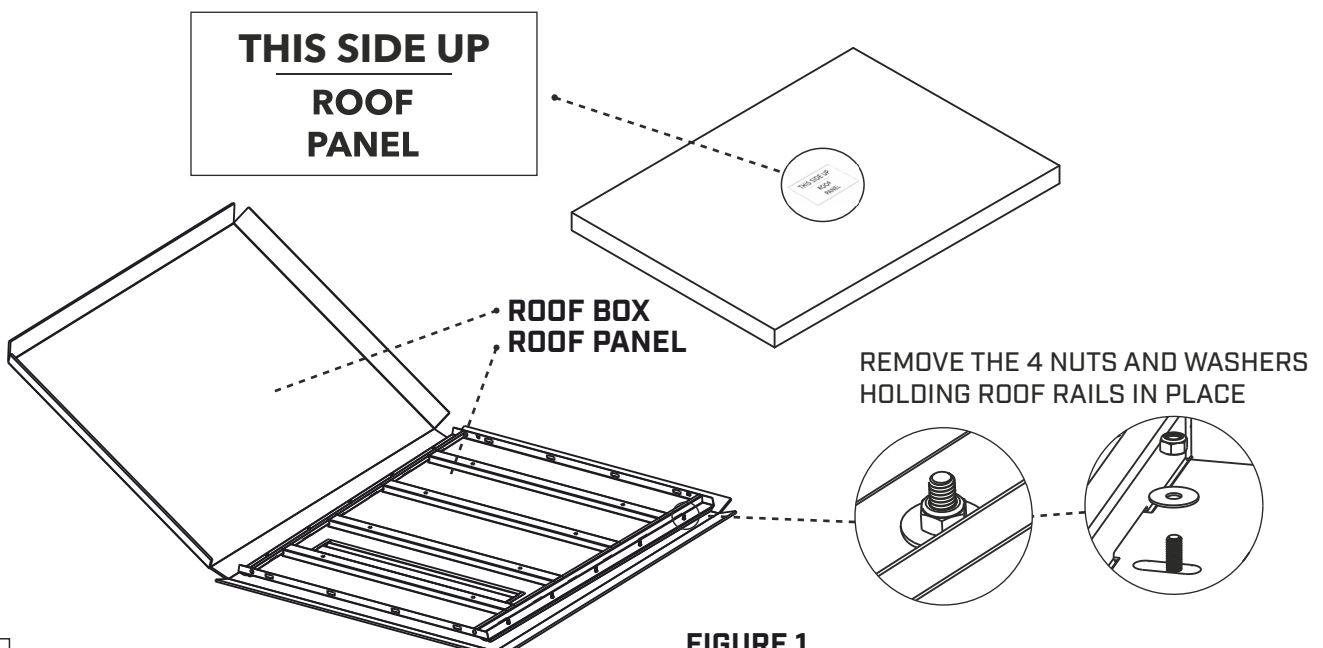

FIGURE 1

ASSEMBLY OF THE CAP

STEP TWO



1. REMOVE THE LEFT SIDE PANEL FROM ITS PACKAGING AND PROTECTIVE PLASTIC BAG.
2. YOU WILL NOTICE ONE END OF THE PANEL IS SLANTED. TO ENSURE IT'S CORRECTLY ORIENTATED, PLACE THE SLANTED END TOWARDS THE AIR-VENT ON THE ROOF PANEL.
3. ONCE ORIENTATED CORRECTLY, INSERT THE SIDE PANEL INTO THE ROOF. [SEE FIGURE 2]
4. TO ALLOW GREATER FLEXIBILITY FOR PANEL FITMENT, ONLY HAND TIGHTEN HARDWARE AT THIS STAGE. [SEE FIGURE 3]
5. WORK WITH CAUTION TO PREVENT ANY DAMAGE.

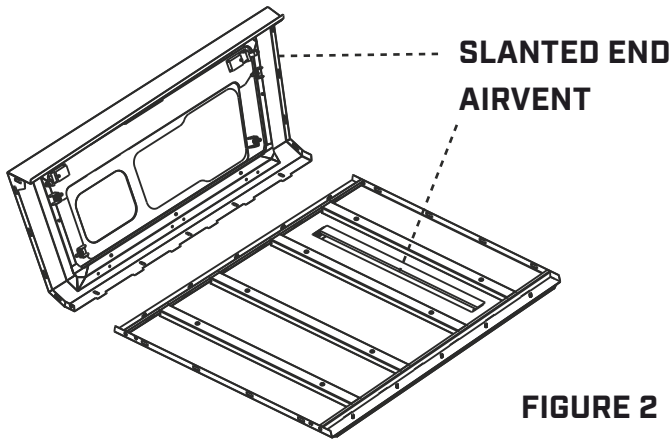

HOOK THE SIDE PANEL INTO THE ROOF, CORRECTLY ORIENTATED, SLANTED END OF SIDE PANEL TO FACE THE DIRECTION OF THE ROOF AIR-VENT.

FIGURE 2

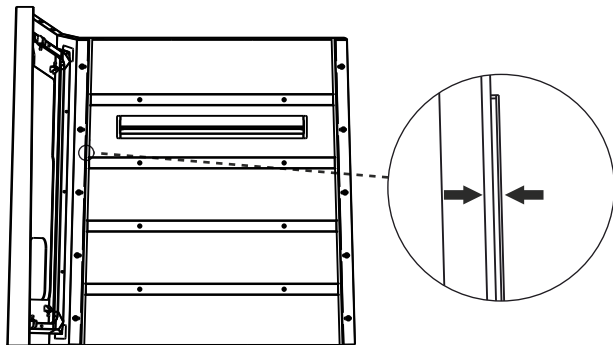

GENTLY TAP THE SIDE PANEL INTO PLACE, ENSURING THE GAP BETWEEN THE SIDE PANEL AND ROOF IS MINIMAL.

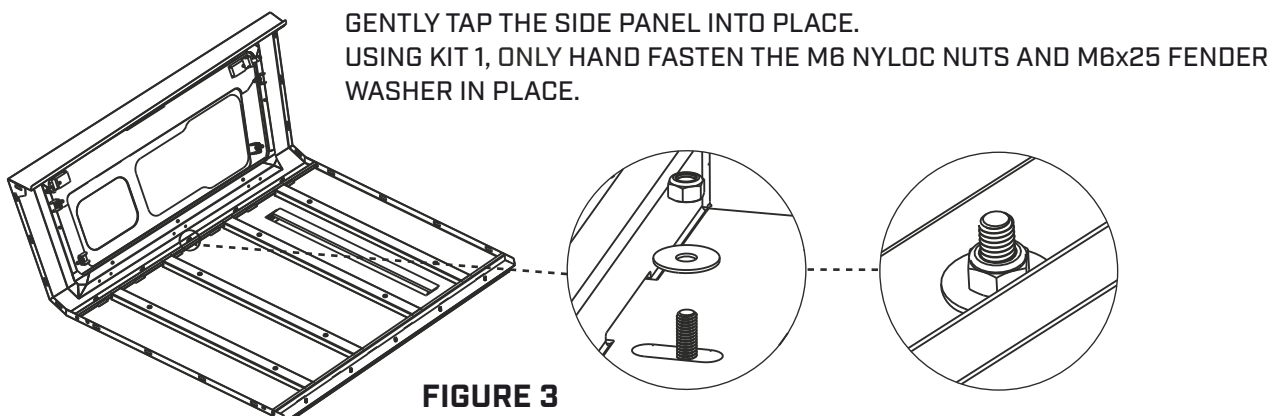

FIGURE 3



ASSEMBLY OF THE CAP

STEP THREE



1. REMOVE THE RIGHT HAND SIDE PANEL FROM ITS PACKAGING AND PROTECTIVE PLASTIC BAG.
2. HOOK THE SIDE PANEL INTO THE ROOF. [SEE FIGURE 4]
3. HAND FASTEN THE HARDWARE IN PLACE. [SEE FIGURE 5]
4. WORK WITH CAUTION TO PREVENT ANY DAMAGE.

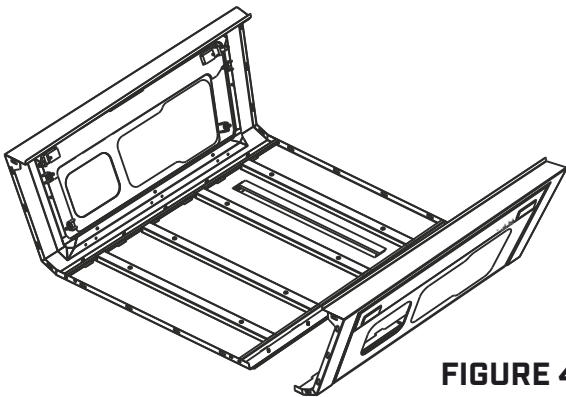
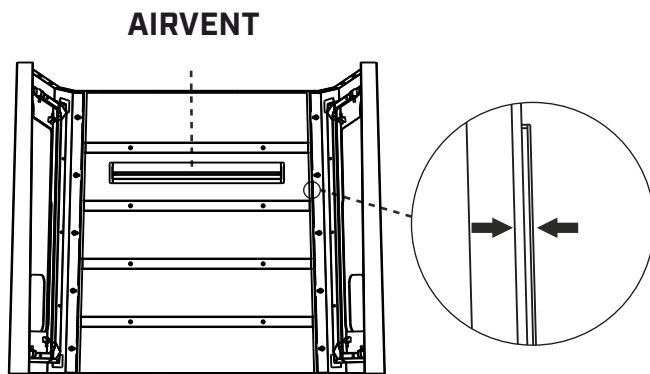
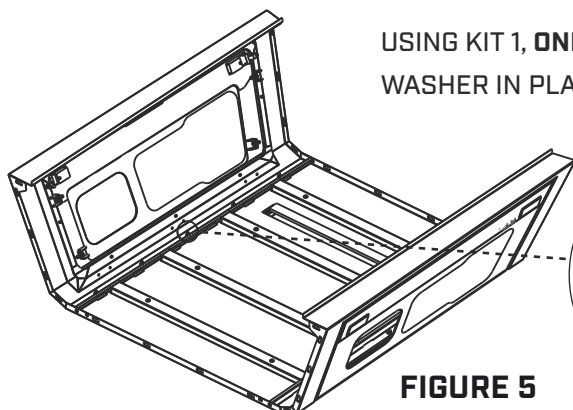

FIGURE 4

HOOK THE SIDE PANEL INTO THE ROOF, CORRECTLY ORIENTATED, SLANTED END OF THE SIDE PANEL TO FACE THE DIRECTION OF THE ROOF AIR-VENT.



GENTLY TAP THE SIDE PANEL INTO PLACE, ENSURING THE GAP BETWEEN THE SIDE PANEL AND ROOF IS MINIMAL.



USING KIT 1, **ONLY HAND FASTEN** THE M6 NYLOC NUTS AND M6x25 FENDER WASHER IN PLACE.

FIGURE 5

ASSEMBLY OF THE CAP

STEP FOUR

1. LOCATE THE FRONT FLANGE AND REMOVE IT FROM THE PACKAGING.
2. REFER TO PAGE 4 TO DETERMINE WHICH SET OF HARDWARE YOU HAVE (VERSION A OR B).
3. USE A 10MM COMBINATION WRENCH TO REMOVE ALL HARDWARE FROM THE FRONT FLANGE AND SAVE FOR REUSE.
4. PLACE FRONT FLANGE AS SHOWN BELOW.

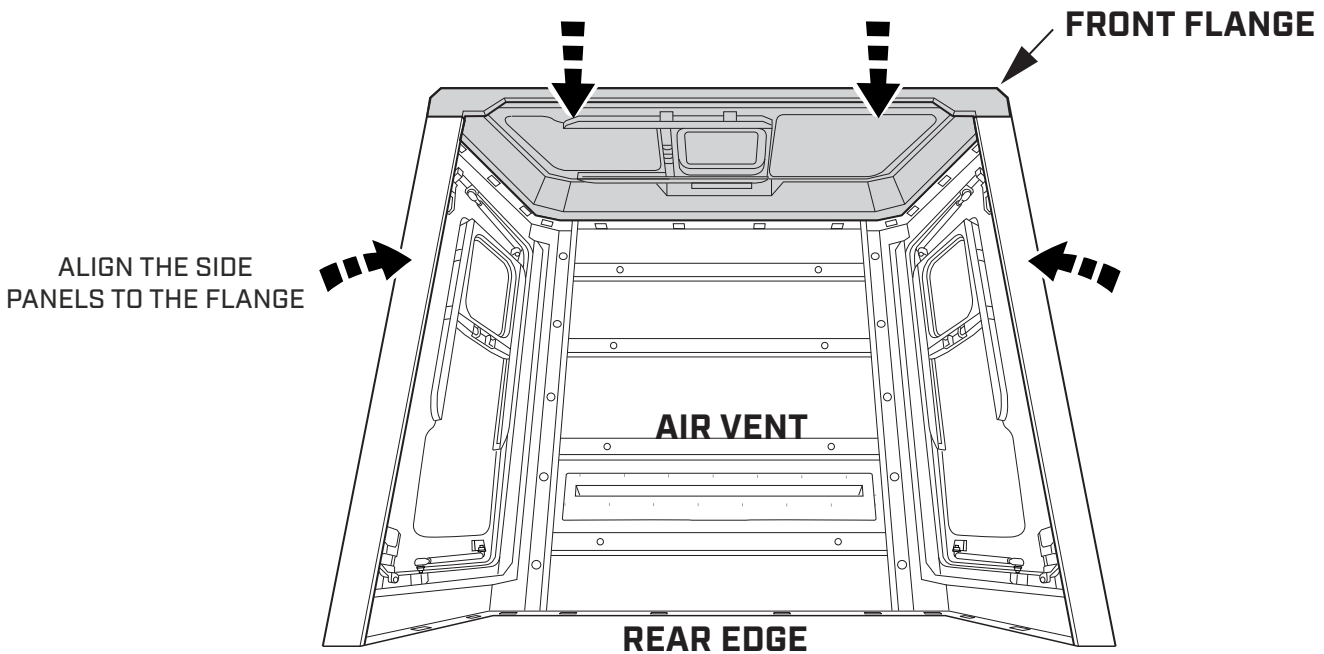
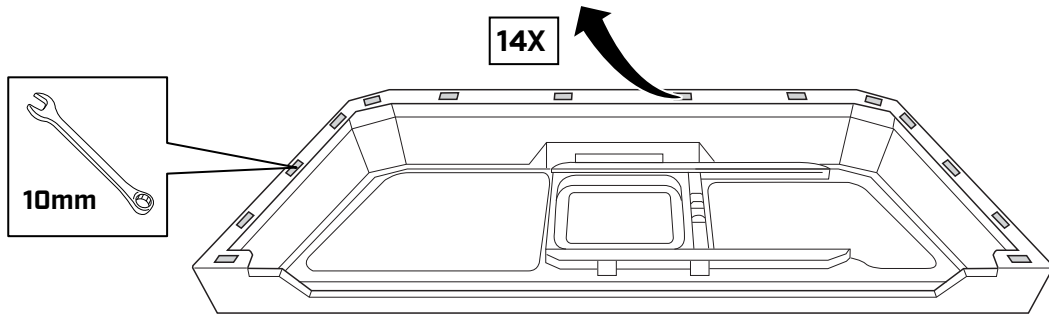
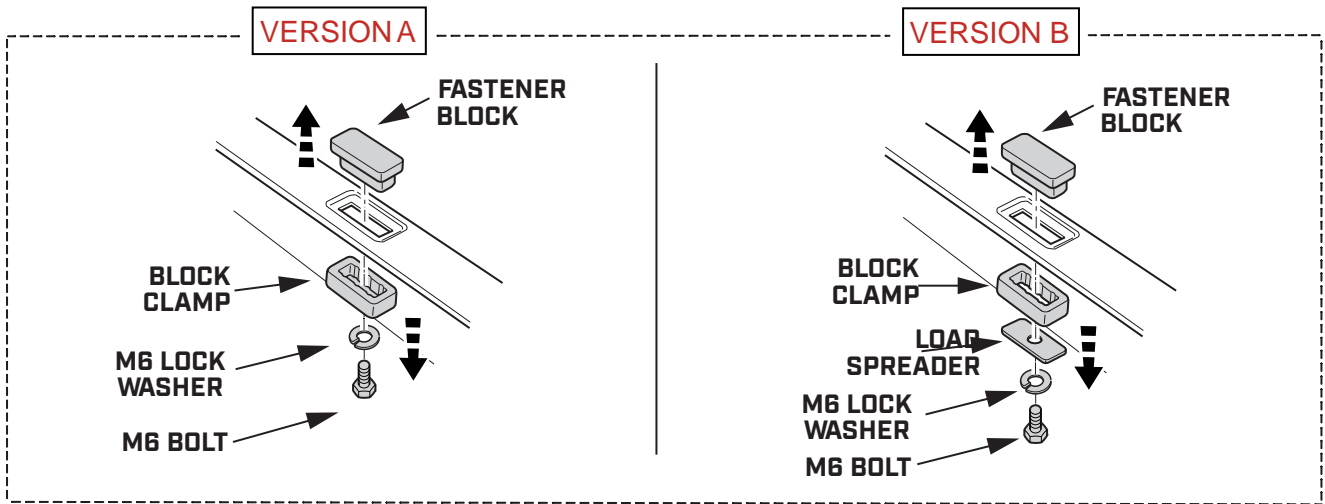

ASSEMBLY OF THE CAP

STEP FIVE

1. INSTALL HARDWARE ALONG FRONT FLANGE WITH M6 BOLT ON THE INSIDE.
2. START WITH ASSEMBLING FASTENER BLOCKS 1-5.
3. ADJUST LEFT AND RIGHT PANELS TO ALIGN FASTENER BLOCKS 6-15 FOR ASSEMBLY.
4. HAND TIGHTEN IN THE SEQUENCE SHOWN.

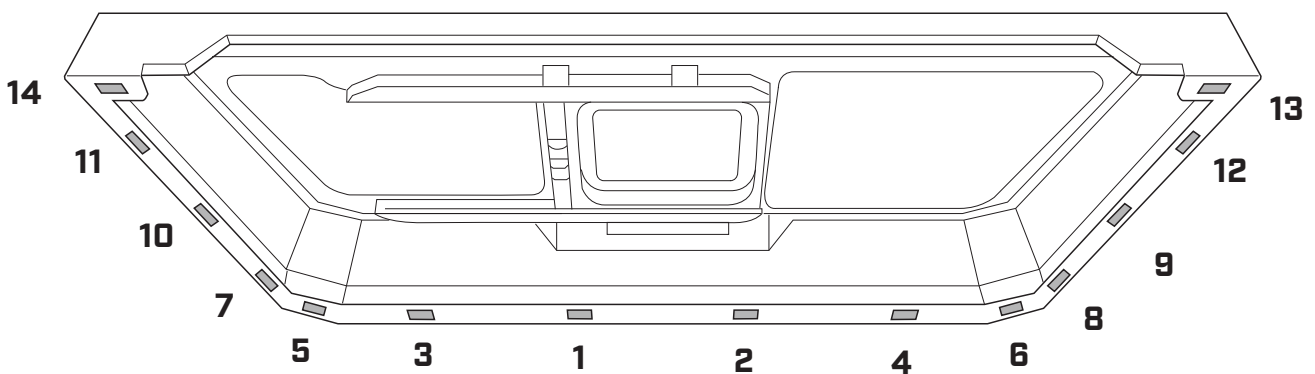
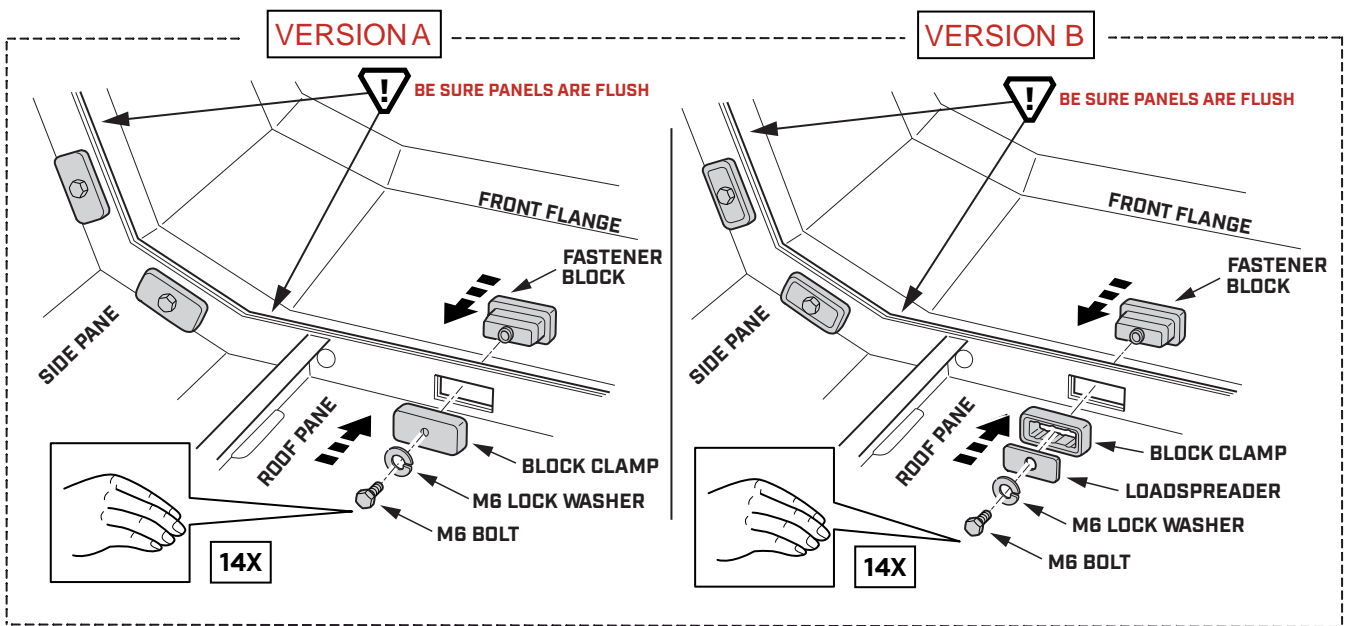

FOLLOW THE TIGHTENING SEQUENCE 1-14

ASSEMBLY OF THE CAP

STEP SIX

1. LOCATE THE REAR FLANGE AND REMOVE THE PACKAGING.
2. USE A 10MM COMBINATION WRENCH TO REMOVE ALL HARDWARE FROM THE REAR FLANGE AND SAVE FOR REUSE.
2. PLACE REAR FLANGE AS SHOWN BELOW.

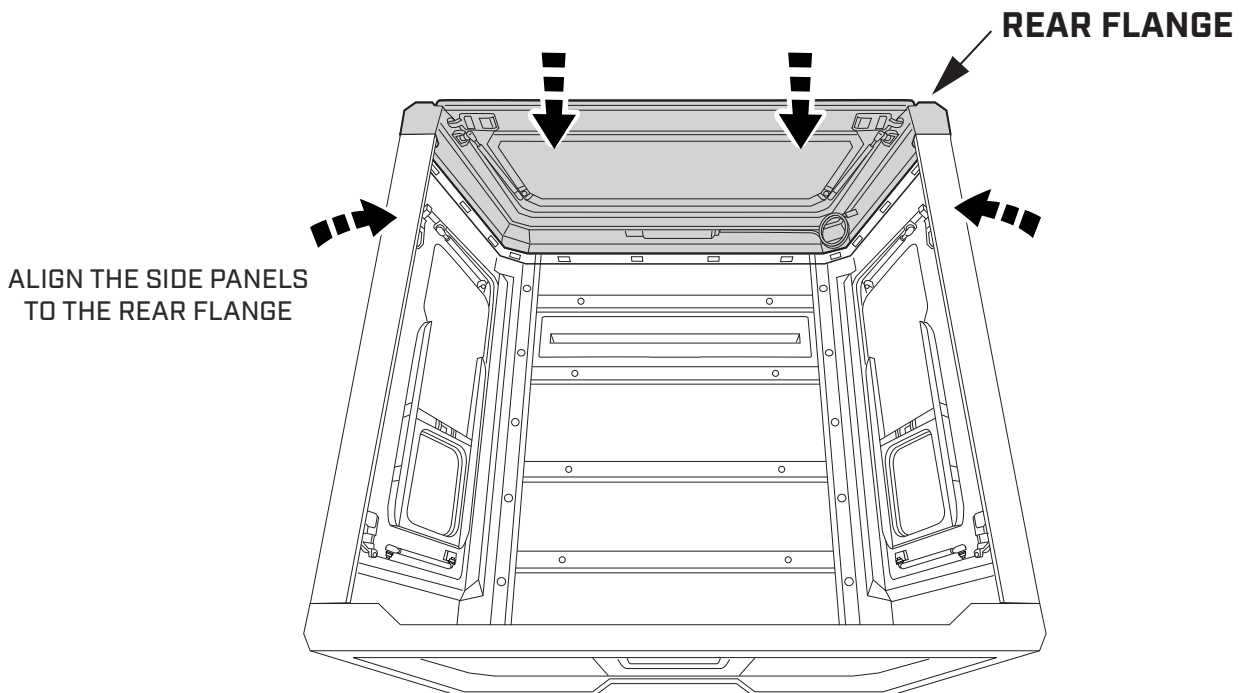
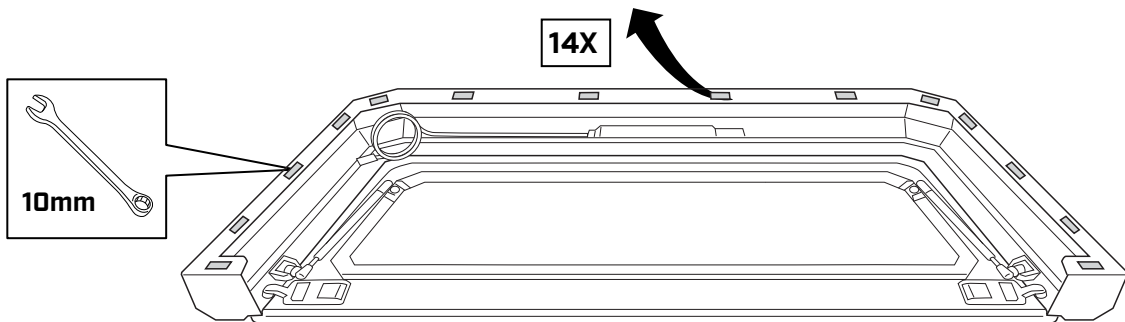
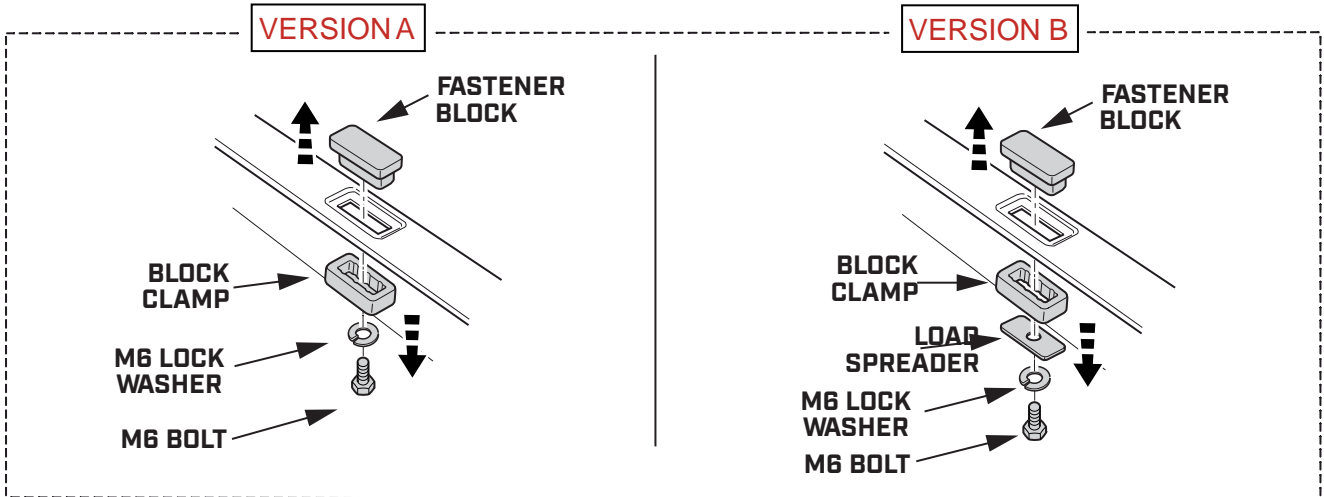

ASSEMBLY OF THE CAP

STEP SEVEN

1. INSTALL HARDWARE ALONG REAR FLANGE WITH M6 BOLT ON THE INSIDE.
2. START WITH ASSEMBLING FASTENER BLOCKS 1-5.
3. ADJUST LEFT AND RIGHT PANELS TO ALIGN FASTENER BLOCKS 6-15 FOR ASSEMBLY.
4. HAND TIGHTEN IN THE SEQUENCE SHOWN.

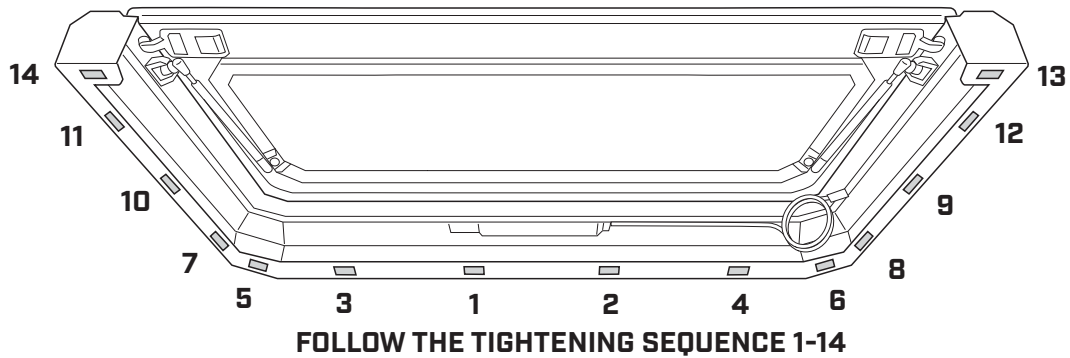
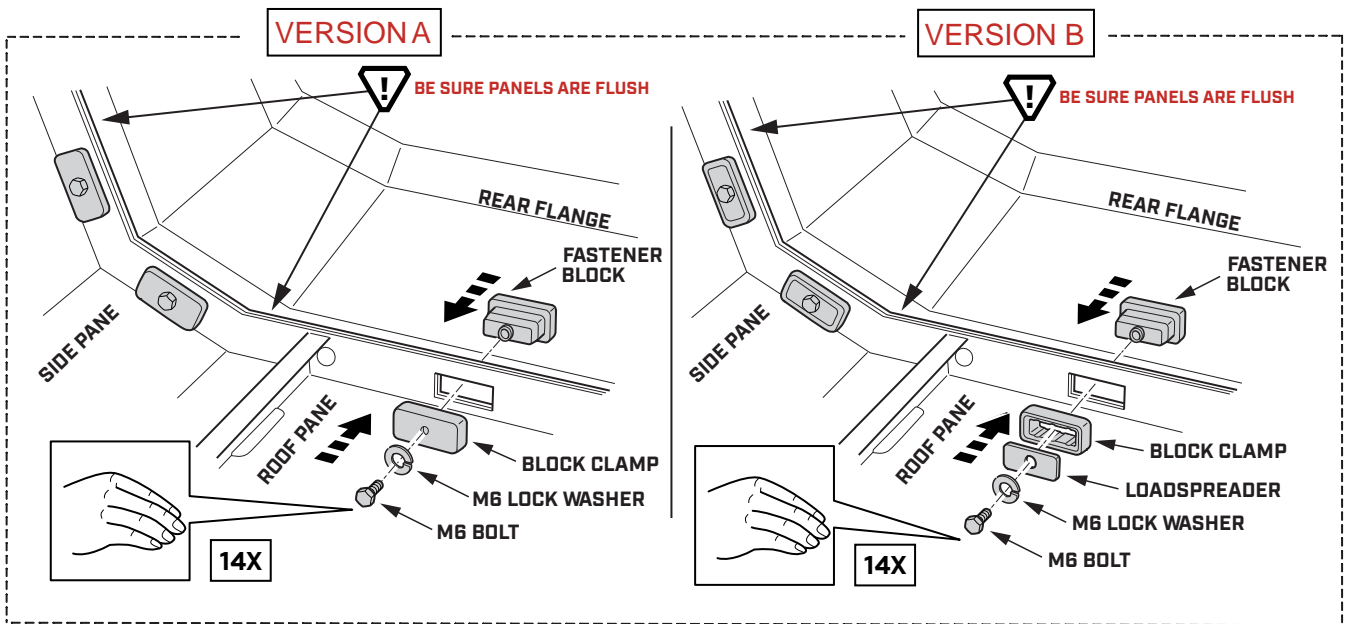

STEP EIGHT

1. ONCE THE SMARTCAP IS FULLY ASSEMBLED AND HAND-TIGHTENED. PROCEED TO TORQUE THE FRONT AND REAR FLANGE FASTENERS 3.7 FT. LBS. [5 NEWTON METERS]
2. PROCEED TO TORQUE THE M6 NYLOC NUTS WHICH WERE PREVIOUSLY HAND FASTENED TO THE ROOF IN STEPS 2 & 3 [SEE FIGURE 8] 3.7 FT. LBS. [5 NEWTON METERS]

FIGURE 8

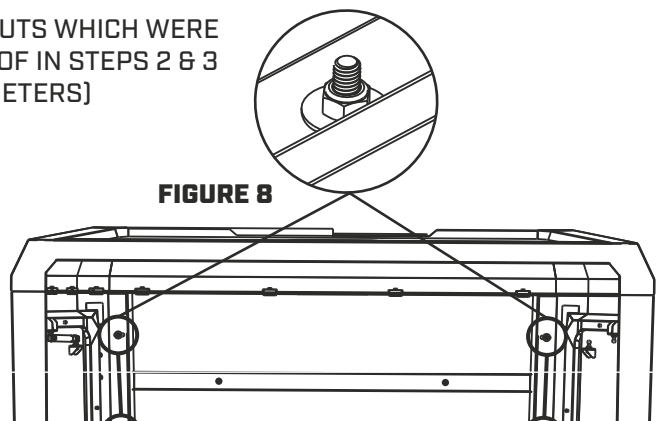

ASSEMBLY OF THE CAP

STEP NINE

1. REFER TO PAGE 5 TO DETERMINE WHICH SET OF HARDWARE YOU HAVE (VERSION A OR B).

VERSION A

- A** LOCATE THE D-RUBBER RETENTION TAB NEXT TO THE REAR DOOR GASKET. BEND THE TAB UPWARDS AT A 45 DEGREE ANGLE.

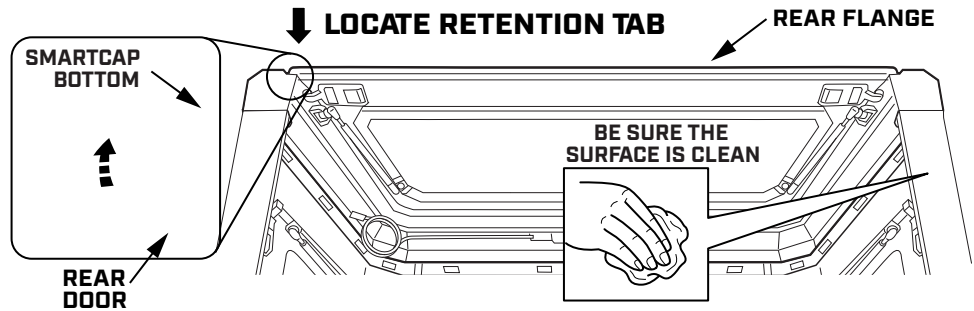

- B** PEEL AWAY A SMALL PORTION OF THE ADHESIVE BACKING FROM THE D-RUBBER.

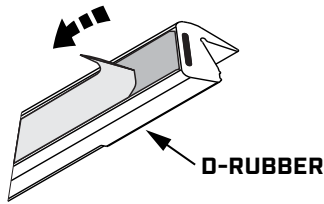

- C** INSERT IT INTO THE TAB UNTIL THE D-RUBBER LIGHTLY BUTTS UP AGAINST REAR DOOR GASKET.

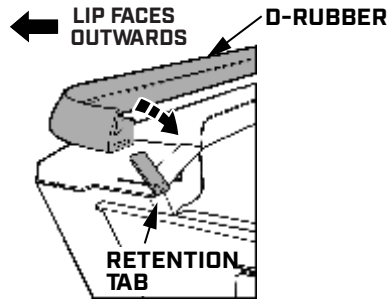

- D** FIRMLY PUSH THE TAB BACK DOWN TO SECURE THE D-RUBBER IN PLACE.

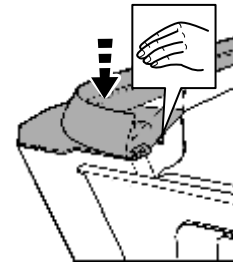

VERSION B

APPLY D-RUBBER TO BOTTOM OF SMARTCAP WITH END LIGHTLY BUTTED AGAINST THE REAR DOOR GASKET.

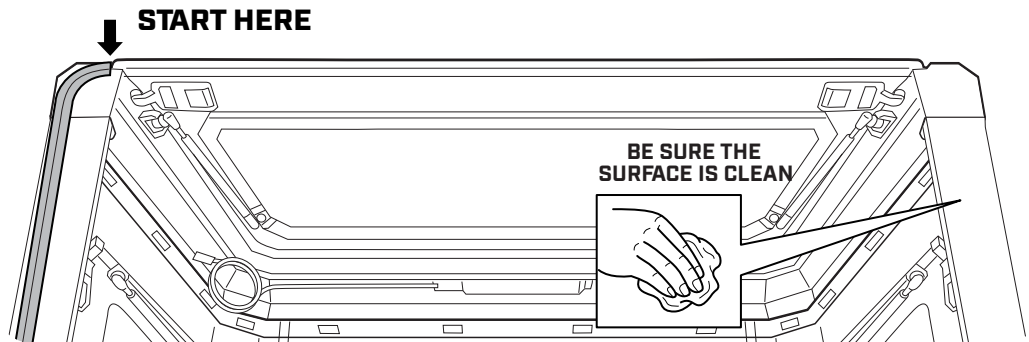

- A** POSITION THE D-RUBBER ALONG THE OUTSIDE EDGE OF THE SMARTCAP.

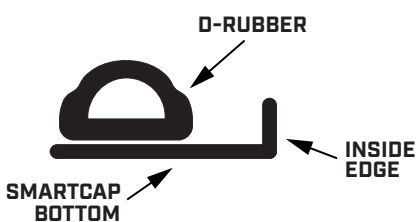

- B** PEEL ADHESIVE BACKING IN SMALL LENGTHS AS YOU WORK AROUND THE SMARTCAP.

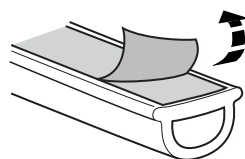

- C** STAY WITHIN 1/8 INCH FROM THE SMARTCAP'S OUTER EDGES.

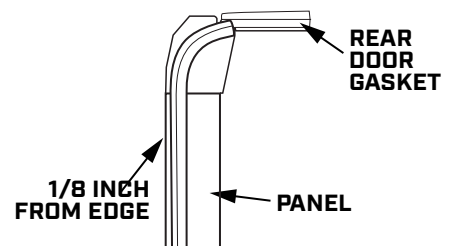

ASSEMBLY OF THE CAP

STEP TEN

VERSION A

PEEL AWAY ADHESIVE BACKING IN SHORT LENGTHS AS YOU WORK AROUND THE EDGES.

STAY WITHIN 1/8 INCH FROM THE SMARTCAP'S OUTER EDGES.

REMOVE EXCESS WITH A STRAIGHT CUT.

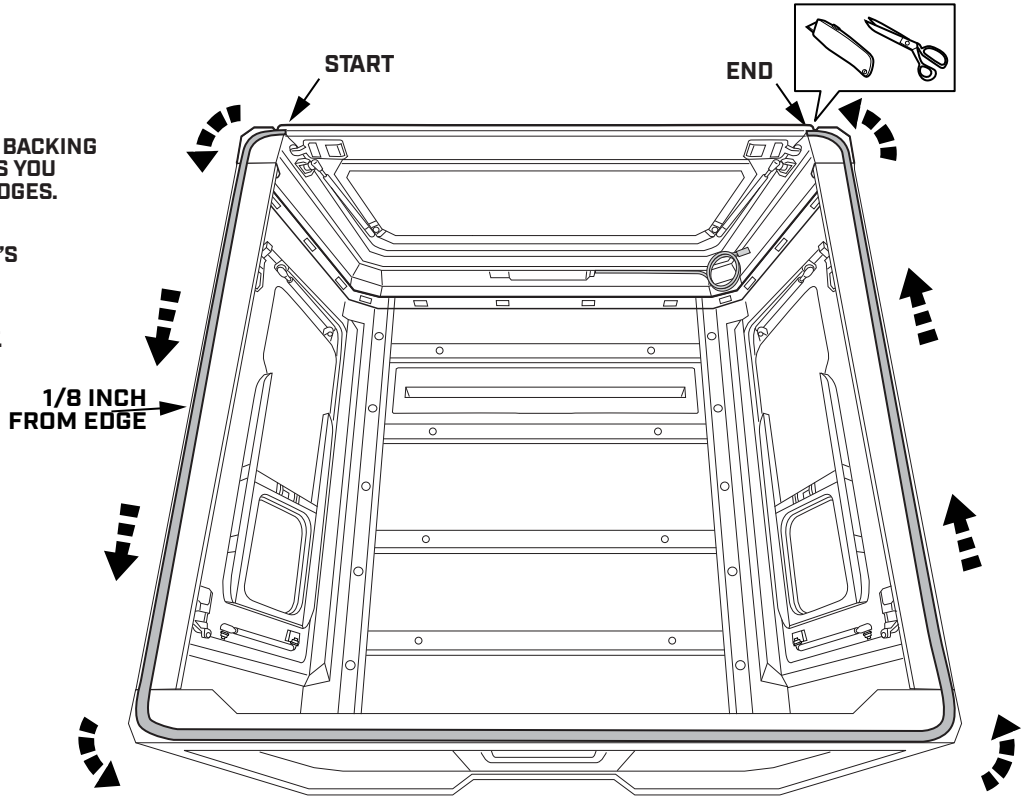

VERSION B





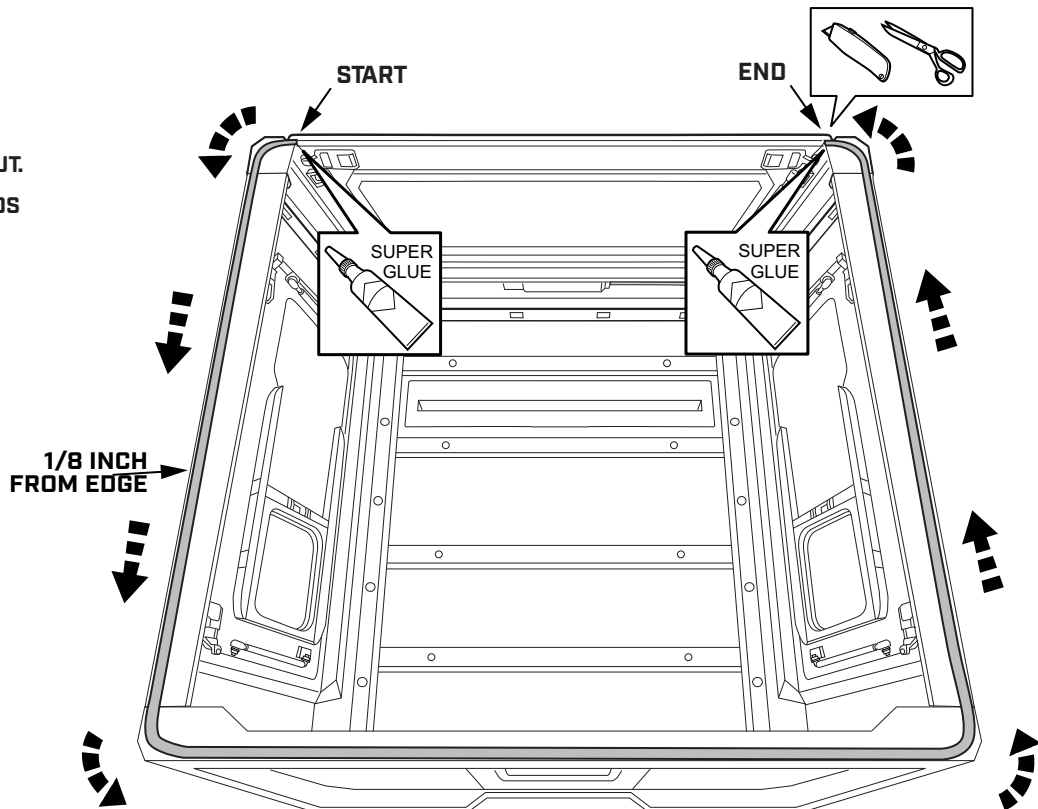





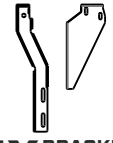

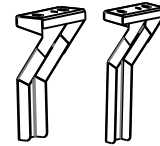
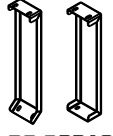

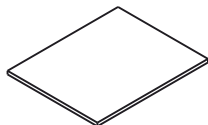

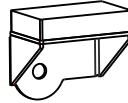
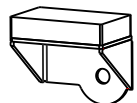
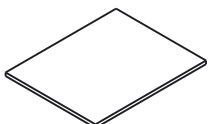
REMOVE EXCESS WITH A STRAIGHT CUT.

REINFORCE THE ENDS OF THE D-RUBBER WITH SUPERGLUE.



INSTALLATION COMPONENTS

FITMENT KIT CONTENT (HARDWARE)

<p>FORD RANGER</p> <p>[PG.15]</p>	 <p>4X BRACKETS FORD RANGER</p>	 <p>1X 5MM X 30MM FOAM SEAL TAPE</p>		
<p>TOYOTA HILUX</p> <p>[PG.18]</p>	 <p>4X BRACKETS TOYOTA HILUX</p>			
<p>VW AMAROK</p> <p>[PG.21]</p>	 <p>4X BRACKET KIT VW AMAROK</p>	 <p>8X THICK RUBBER PAD</p>		
<p>ISUZU D-MAX</p> <p>[PG.22]</p>	 <p>6X THIN RUBBER PAD</p>	 <p>6X CLAMPS ISUZU</p>	 <p>1X LEFT MOUNTING BRACKET</p>	 <p>1X RIGHT MOUNTING BRACKET</p>
<p>MITSUBISHI TRITON</p> <p>[PG.23]</p>	 <p>6X THIN RUBBER PAD</p>	 <p>6X CLAMPS ISUZU</p>	 <p>2X D-RUBBER 1700MM</p>	 <p>1X 5MM X 30MM FOAM SEAL TAPE</p>
<p>TOYOTA LAND CRUISER</p> <p>[PG.24]</p>	 <p>6X M8 X 30 HEX BOLT</p>	 <p>6X M8 NYLOC NUT</p>	 <p>12X M8 X 25 FENDER WASHER</p>	 <p>6X 48MM PLASTIC END CAPS</p>
	 <p>2X D-RUBBER 1700MM</p>	 <p>4X 30MM X 10MM X 1595MM FOAM SEAL TAPE</p>		

INSTALLATION OF THE SMARTCAP

STEP ONE



1. SOME TRUCK BEDS MAY HAVE HEIGHT DIFFERENCES BETWEEN THE SIDES AND FRONT OF THE TRUCK BED. IF THAT IS THE CASE WITH YOUR TRUCK BED, APPLY A FOAM STRIP TO THE LIP OF THE FRONT PANEL.
2. REMOVE THE ADHESIVE BACKING TAPE FROM THE FOAM STRIP. [SEE FIGURE 1 & 2]
3. APPLY FOAM STRIP ON THE FRONT LIP OF THE PICK UP BOX TO ACCOUNT FOR ANY HEIGHT DIFFERENCES BETWEEN THE PICKUP BOX SIDES AND THE FRONT PICKUP BOX PANEL. [SEE FIGURE 2]
4. CUT TO LENGTH [SEE FIGURE 3]

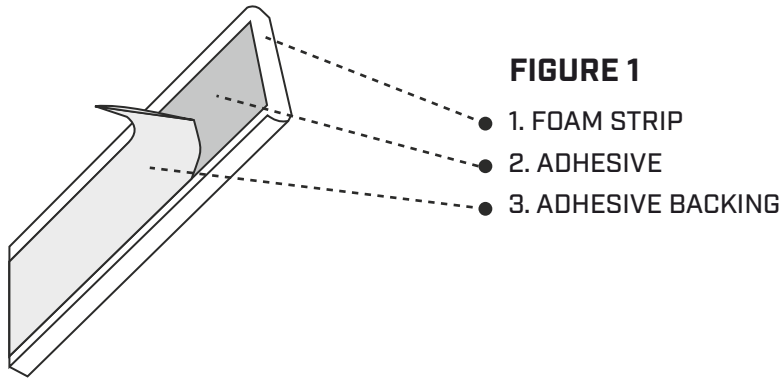

FIGURE 1

- 1. FOAM STRIP
- 2. ADHESIVE
- 3. ADHESIVE BACKING

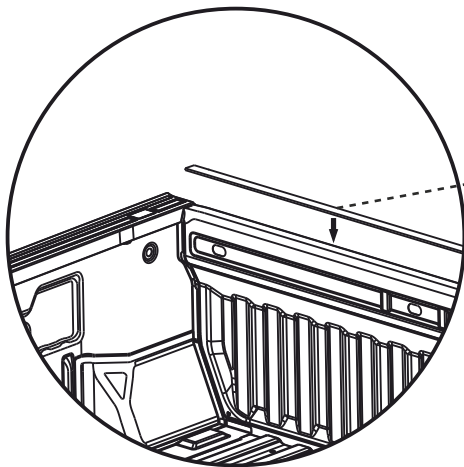

FIGURE 2

FOAM STRIP
FRONT PICKUP BOX PANEL

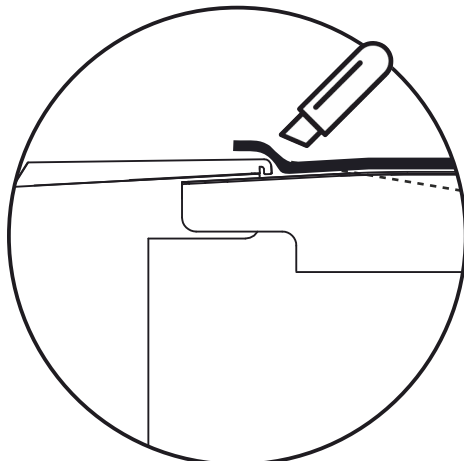

FIGURE 3

FOAM STRIP
TRIM EXCESS FOAM STRIP

INSTALLATION

FORD RANGER

STEP ONE



1. SOME TRUCK BEDS MAY HAVE HEIGHT DIFFERENCES BETWEEN THE SIDES AND FRONT OF THE TRUCK BED. IF THAT IS THE CASE WITH YOUR TRUCK BED, APPLY A FOAM STRIP TO THE LIP OF THE FRONT PANEL.
2. REMOVE THE ADHESIVE BACKING TAPE FROM THE FOAM STRIP. [SEE FIGURE 1]
3. APPLY FOAM STRIP ON THE FRONT LIP OF THE PICK UP BOX TO ACCOUNT FOR ANY HEIGHT DIFFERENCES BETWEEN THE PICKUP BOX SIDES AND THE FRONT PICKUP BOX PANEL. [SEE FIGURE 2]
4. CUT TO LENGTH. [SEE FIGURE 3]

FIGURE 1

- 1. FOAM STRIP
- 2. ADHESIVE
- 3. ADHESIVE BACKING

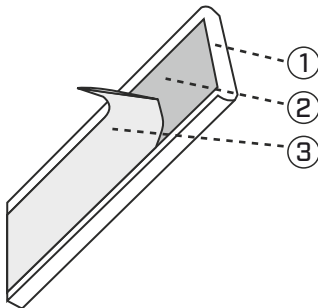

FIGURE 2

- FOAM STRIP FRONT PICKUP BOX PANEL

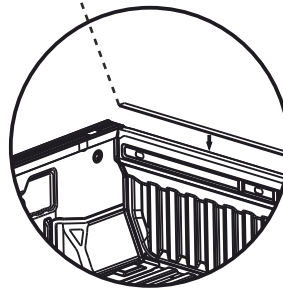
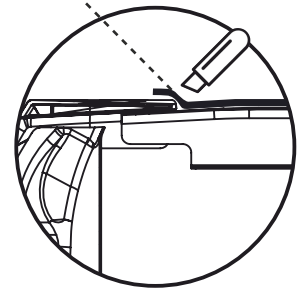

FIGURE 3

- FOAM STRIP TRIM EXCESS FOAM STRIP



STEP TWO



1. POSITION THE FRONT MOUNT BRACKET IN THE FRONT LEFT HAND CORNER OF THE LOAD BIN.
2. USE ONE M6 SET SCREW, WITH M6 SPRING WASHER AND M6 FENDER WASHER TO LOOSELY SCREW THE BRACKET TO THE FRONT OF THE LOAD BIN.
3. USE TWO M8 X 25 SET SCREWS WITH TWO M8 SPRING WASHERS AND M8 X 25 FENDER WASHERS TO FASTEN THE BRACKET TO THE SIDE OF THE LOAD BIN
4. REPEAT THIS PROCESS IN THE FRONT MOUNT BRACKET RIGHT HAND SIDE IN THE FRONT RIGHT HAND CORNER OF THE LOAD BIN.
5. TIGHTEN THE M8 HARDWARE TO 12NM AND M6 HARDWARE TO 9NM.

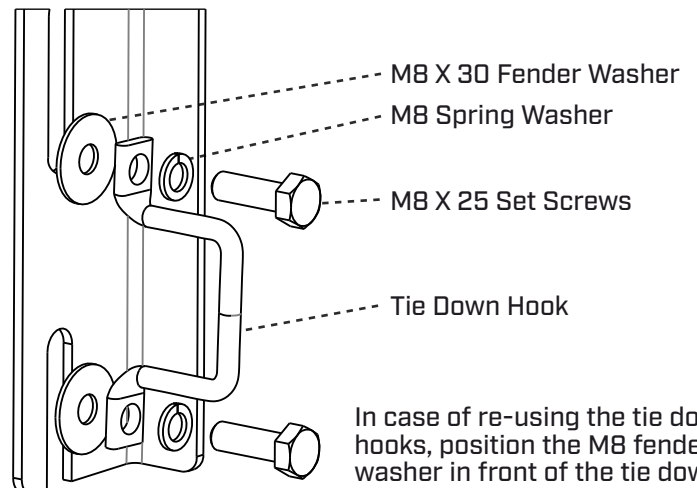
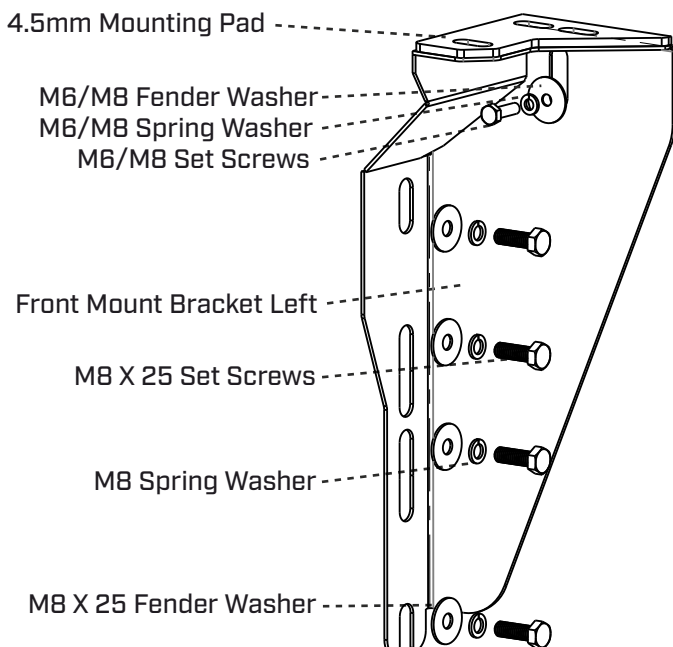

In case of re-using the tie down hooks, position the M8 fender washer in front of the tie down hook, then the M8 spring washer and lastly the M8 set screw.

INSTALLATION

FORD RANGER

STEP THREE



1. POSITION THE REAR MOUNT BRACKET LEFT HAND IN THE REAR LEFT HAND CORNER OF THE LOAD BIN.
2. USE TWO M8 X 25 SET SCREWS WITH M8 SPRING WASHERS AND M8 X 25 FENDER WASHERS TO LOOSELY SCREW THE BRACKET TO THE REAR OF THE LOAD BIN.
3. REPEAT THIS PROCESS IN THE REAR MOUNT BRACKET RIGHT HAND SIDE IN THE REAR RIGHT HAND CORNER OF THE LOAD BIN.
4. ONLY TIGHTEN THE M8 HARDWARE TO 12NM AFTER THE SMARTCAP HEIGHT HAS BEEN ADJUSTED AS STATED IN STEP FOUR.

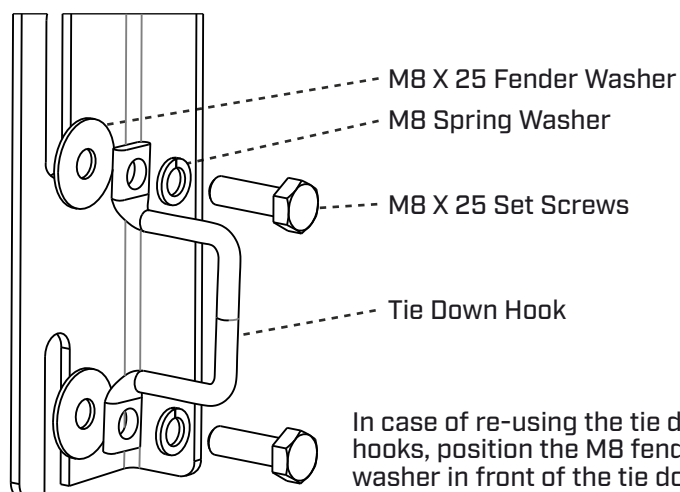
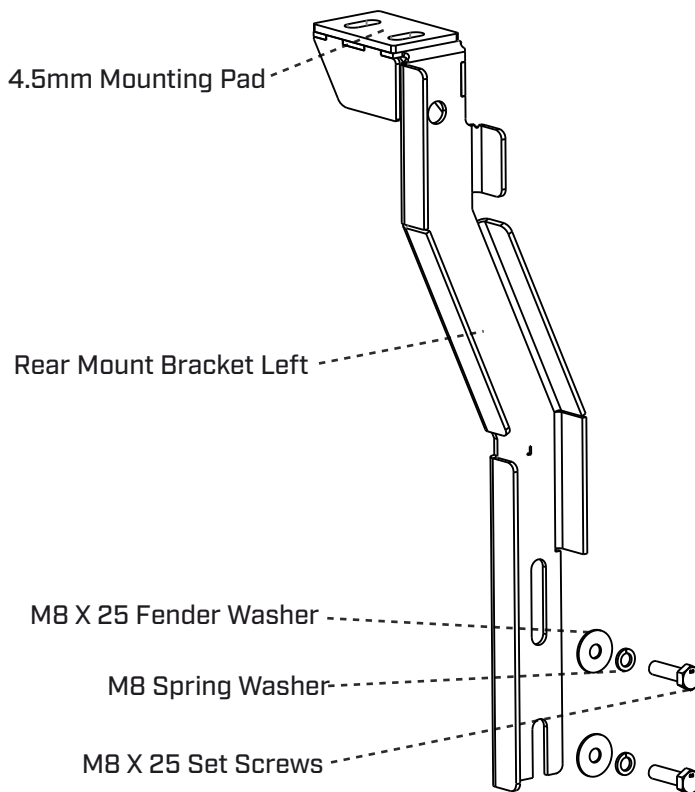

In case of re-using the tie down hooks, position the M8 fender washer in front of the tie down hook, then the M8 spring washer and lastly the M8 set screw.

INSTALLATION

FORD RANGER

STEP FOUR

1. PLACE THE SMARTCAP ONTO THE LOAD BIN.
2. PLEASE LIFT WITH CAUTION TO PREVENT POSSIBLE INJURY. IT IS RECOMMENDED THAT A MINIMUM OF FOUR PEOPLE ARE USED TO LIFT THE SMARTCAP.
3. MAKE SURE THE CAP IS IN ITS CORRECT POSITION BY LINING UP THE SLOTS ON THE SMARTCAP WITH THE SLOTS ON THE MOUNTING BRACKETS.
4. USE SIX M8 X 25 SET SCREWS WITH TWELVE M8 X 25 FENDER WASHERS AND SIX M8 NYLOC NUTS TO LOOSELY FASTEN THE SMARTCAP TO THE FRONT MOUNT BRACKETS.
5. USE FOUR M8 X 25 SET SCREWS WITH EIGHT M8 X 25 FENDER WASHERS AND FOUR M8 NYLOC NUTS TO LOOSELY FASTEN SMARTCAP TO THE REAR MOUNT BRACKETS.
6. ONCE ALL SET SCREWS ARE IN POSITION, FASTEN TO 4.4 FT. LBS. (6 NEWTON METERS)
7. ADJUST REAR BRACKETS TO ACHIEVE 2 - 3MM COMPRESSION OF THE D-RUBBER ON THE TAILGATE. TAILGATE SHOULD SLIGHTLY GRAZE THE D-RUBBER WHEN CLOSING. [SEE FIGURE 3.1]
8. CONTINUE TO TIGHTEN REAR BRACKETS TO 4.4 FT. LBS. (6 NEWTON METERS) TO THE LOAD BIN.
9. REPEAT PROCESS ON THE OPPOSITE SIDE OF SMARTCAP.

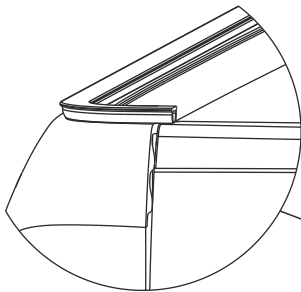

FIGURE 1

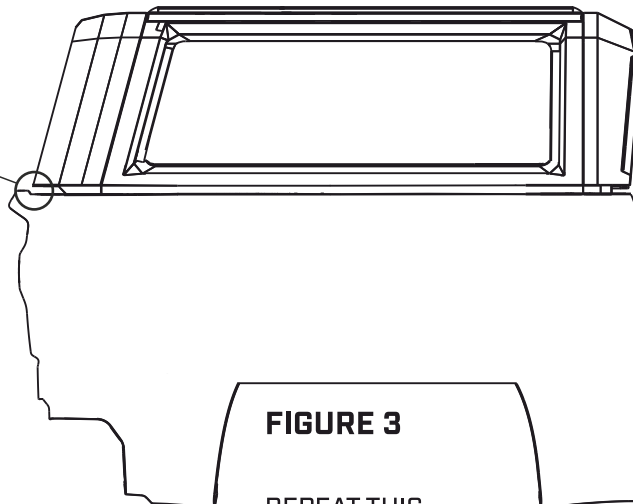
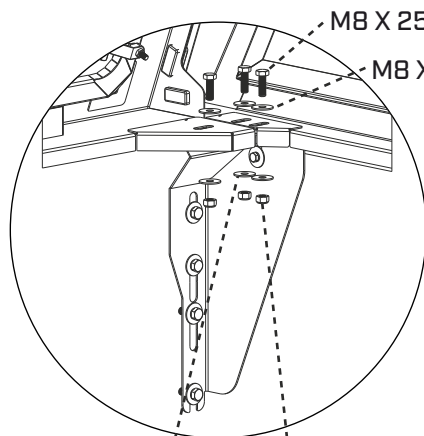

FIGURE 3

REPEAT THIS
PROCEDURE ON THE
OPPOSITE HAND SIDE
OF THE VEHICLE.



M8 X 25 Set Screws

M8 X 25 Fender Washer

M8 X 25 Fender Washer

M8 Nyloc Nut

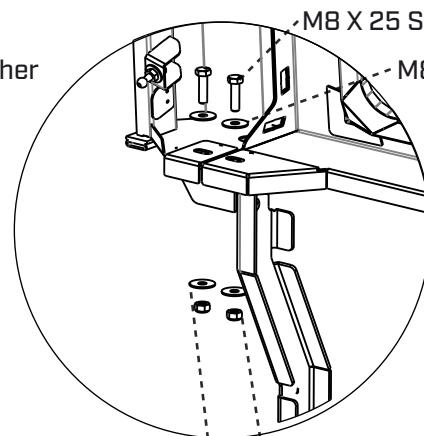

M8 X 25 Set Screws

M8 X 25 Fender Washer

M8 X 25 Fender Washer

M8 Nyloc Nut

INSTALLATION

TOYOTA HILUX

STEP ONE



1. SOME TRUCK BEDS MAY HAVE HEIGHT DIFFERENCES BETWEEN THE SIDES AND FRONT OF THE TRUCK BED. IF THAT IS THE CASE WITH YOUR TRUCK BED, APPLY A FOAM STRIP TO THE LIP OF THE FRONT PANEL.
2. REMOVE THE ADHESIVE BACKING TAPE FROM THE FOAM STRIP. [SEE FIGURE 1]
3. APPLY FOAM STRIP ON THE FRONT LIP OF THE PICK UP BOX TO ACCOUNT FOR ANY HEIGHT DIFFERENCES BETWEEN THE PICKUP BOX SIDES AND THE FRONT PICKUP BOX PANEL. [SEE FIGURE 2]
4. CUT TO LENGTH. [SEE FIGURE 3]

FIGURE 1

- 1. FOAM STRIP
- 2. ADHESIVE
- 3. ADHESIVE BACKING

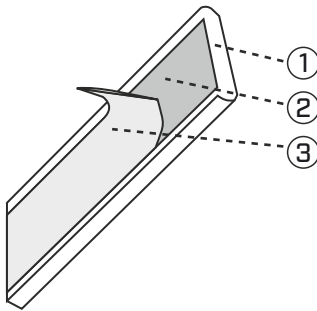

FIGURE 2

- FOAM STRIP FRONT PICKUP BOX PANEL

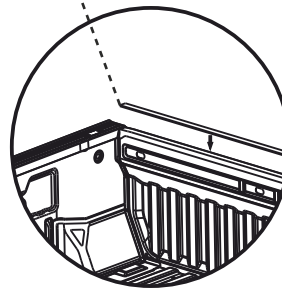
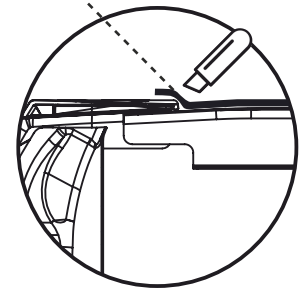

FIGURE 3

- FOAM STRIP TRIM EXCESS FOAM STRIP



STEP TWO



1. POSITION THE FRONT MOUNT BRACKET IN THE FRONT LEFT HAND CORNER OF THE LOAD BIN.
2. USE TWO M8 X 25 SET SCREWS WITH TWO M8 SPRING WASHERS AND M8 X 25 FENDER WASHERS TO FASTEN THE BRACKET TO THE SIDE OF THE LOAD BIN.
3. REPEAT THIS PROCESS IN THE FRONT MOUNT BRACKET RIGHT HAND SIDE IN THE FRONT RIGHT HAND CORNER OF THE LOAD BIN.

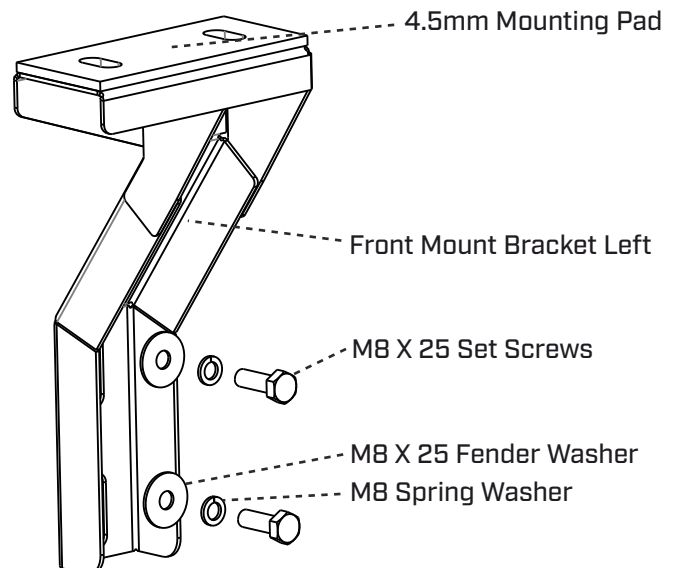
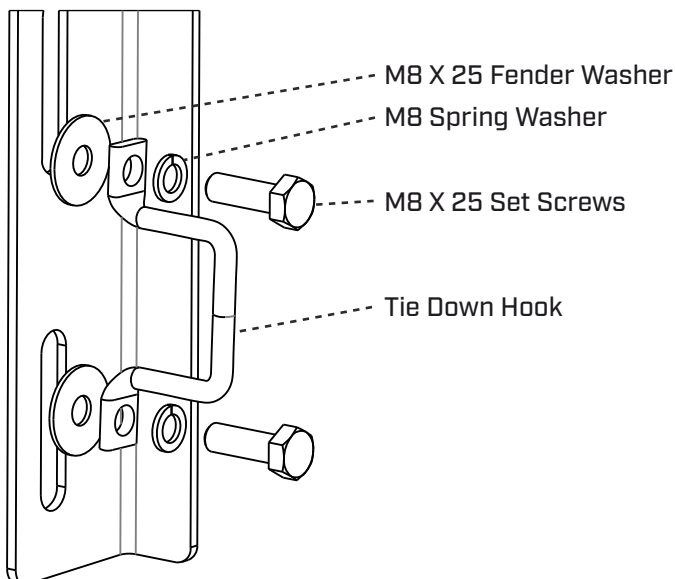

In case of re-using the tie down hooks, position the M8 fender washer in front of the tie down hook, then the M8 spring washer and lastly the M8 set screw.

INSTALLATION

TOYOTA HILUX

STEP THREE



1. POSITION THE REAR MOUNT BRACKET LEFT HAND IN THE REAR LEFT HAND CORNER OF THE LOAD BIN.
2. USE TWO M8 X 25 SET SCREWS WITH TWO M8 SPRING WASHERS AND M8 X 25 FENDER WASHERS TO LOOSELY SCREW THE BRACKET TO THE REAR OF THE LOAD BIN.
3. REPEAT THIS PROCESS IN THE REAR MOUNT BRACKET RIGHT HAND SIDE IN THE REAR RIGHT HAND CORNER OF THE LOAD BIN.

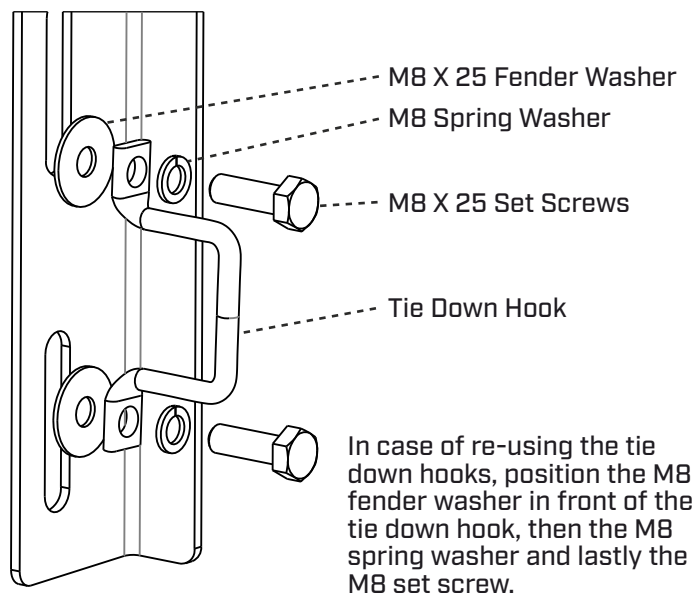
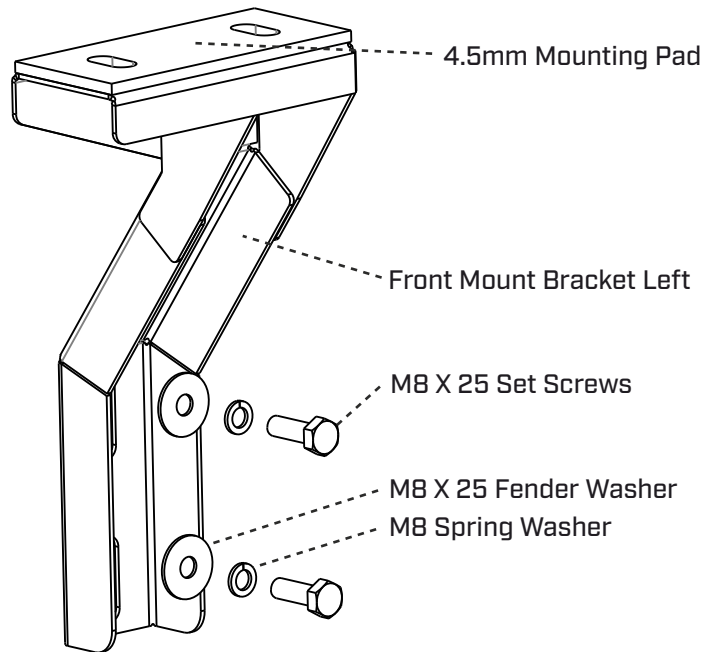

STEP FOUR

1. PLACE THE SMARTCAP ONTO THE LOAD BIN.
2. PLEASE LIFT WITH CAUTION TO PREVENT POSSIBLE INJURY. IT IS RECCOMENDED THAT A MINIMUM OF FOUR PEOPLE ARE USED TO LIFT THE SMARTCAP.
3. MAKE SURE THE CAP IS IN ITS CORRECT POSITION BY LINING UP THE SLOTS ON THE SMARTCAP WITH THE SLOTS ON THE MOUNTING BRACKETS.

INSTALLATION

TOYOTA HILUX

STEP FIVE



1. USE FOUR M8 X 25 SET SCREWS WITH EIGHT M8 X 25 FENDER WASHERS AND FOUR M8 NYLOC NUTS TO LOOSELY FASTEN THE SMARTCAP TO THE FRONT MOUNT BRACKETS.
2. USE FOUR M8 X 25 SET SCREWS WITH EIGHT M8 FLAT WASHERS AND FOUR M8 NYLOC NUTS TO LOOSELY FASTEN THE SMARTCAP TO THE REAR MOUNT BRACKETS.
3. ONCE ALL THE SET SCREWS ARE IN THEIR CORRECT POSITIONS, FASTEN TO 4.4 FT. LBS. [6 NEWTON METERS]
4. ADJUST REAR CLAMPS TO ACHIEVE 2 - 3MM COMPRESSION OF THE D-RUBBER ON THE TAILGATE. TAILGATE SHOULD SLIGHTLY GRAZE THE D-RUBBER WHEN CLOSING. (SEE FIGURE 1)

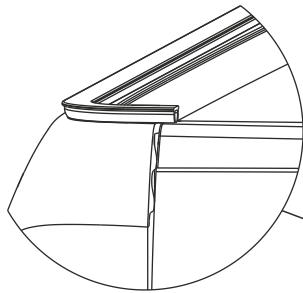

FIGURE 1

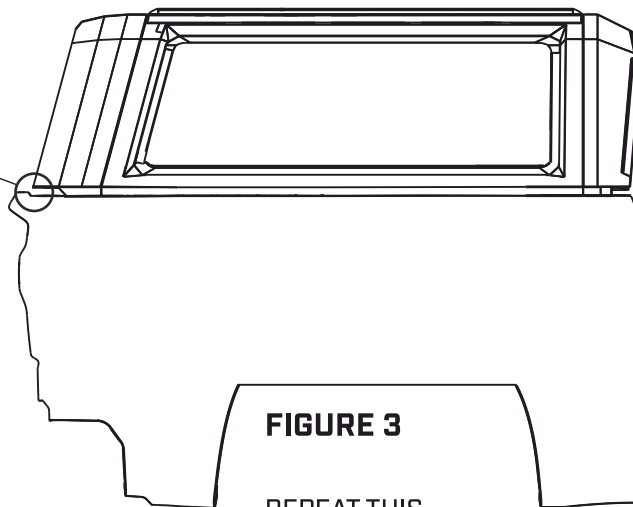
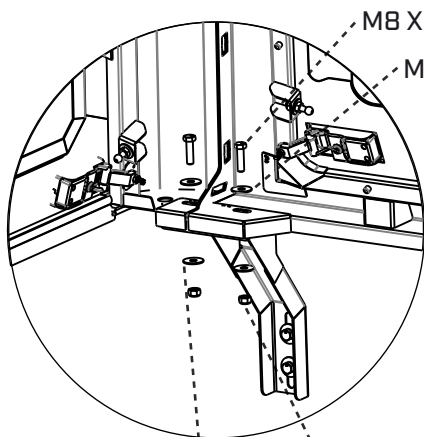

FIGURE 3

REPEAT THIS PROCEDURE ON THE OPPOSITE HAND SIDE OF THE VEHICLE.



M8 X 25 Fender Washer

M8 Nyloc Nut

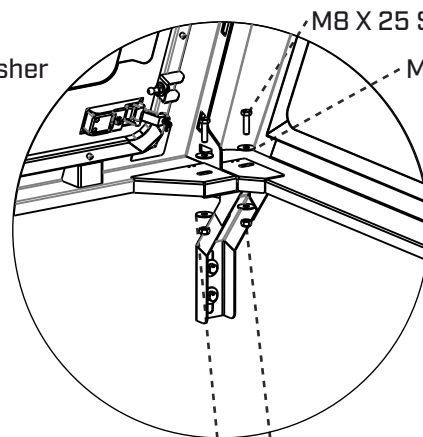

M8 X 25 Fender Washer

M8 Nyloc Nut

INSTALLATION

VW AMAROK

STEP ONE

1. USING THE HARDWARE BELOW, POSITION THE LEFT HAND SIDE REAR BRACKET AND HAND FASTEN ALL HARDWARE IN PLACE.
2. PLEASE WORK WITH CAUTION TO PREVENT UNNECESSARY DAMAGE.
3. REPEAT THE PROCESS ON THE OPPOSITE SIDE.

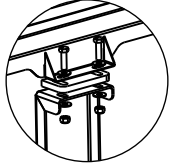

Thick Rubber Pad To Go In Between Canopy And Bracket. The Shorter Foot Mounted to the Cap.

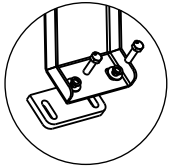

Thick Rubber Pad To Go In Between Bin And Bracket. The Longer Foot Mounted to the Base.

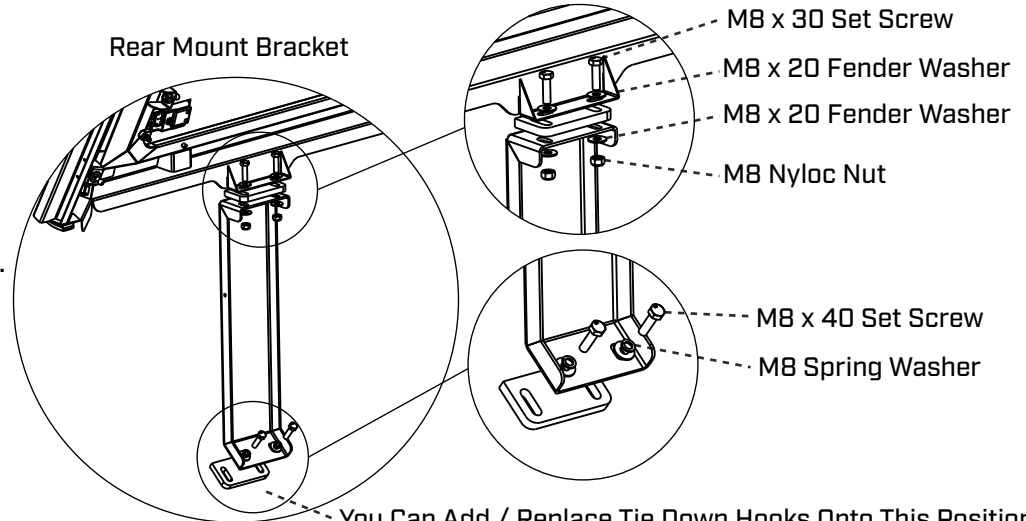

You Can Add / Replace Tie Down Hooks Onto This Position
M8 X 20 Fender Washer Not Required For This Application

STEP TWO

1. POSITION THE FRONT LEFT HAND SIDE BRACKET IN PLACE AND USE THE HARDWARE DEPICTED BELOW TO HAND FASTEN THE FRONT LEFT HAND SIDE MOUNTING BRACKET.
2. WORK WITH CAUTION TO PREVENT UNNECESSARY DAMAGE.
3. REPEAT THE PROCESS ON THE OPPOSITE SIDE.

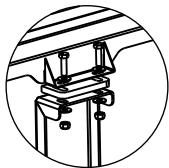

Thick Rubber Pad To Go In Between Canopy And Bracket. The Shorter Foot Mounted to the Cap.

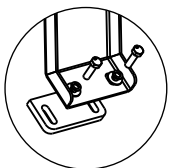

Thick Rubber Pad To Go In Between Bin And Bracket. The Longer Foot Mounted to the Base.

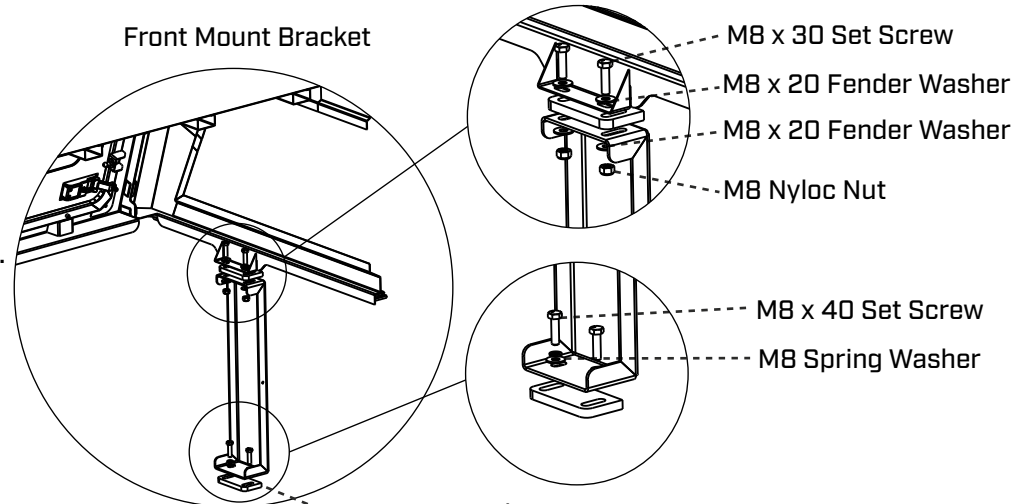

You Can Add / Replace Tie Down Hooks Onto This Position
M8 X 20 Fender Washer Not Required For This Application

STEP THREE

1. PLACE THE SMARTCAP ONTO THE LOAD BIN.
2. MAKE SURE THE RSI SMARTCAP IS IN ITS CORRECT POSITION BY LINING UP THE SLOTS ON THE RSI SMARTCAP WITH THE SLOTS ON THE MOUNTING BRACKET.
3. PLEASE LIFT WITH CAUTION TO PREVENT POSSIBLE INJURY. IT IS RECOMMENDED A MINIMUM OF FOUR PEOPLE ARE USED TO LIFT THE SMARTCAP.
4. ONCE ALL THE SET SCREWS ARE IN THEIR CORRECT POSITIONS, 4.4 FT. LBS. [6 NEWTON METERS]

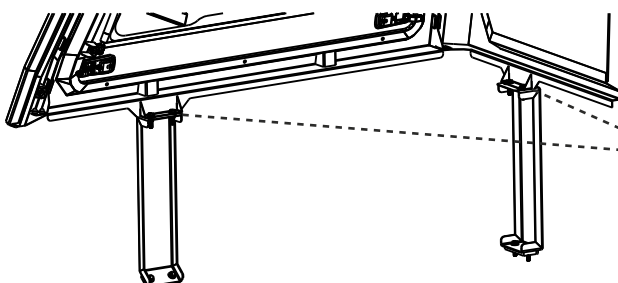

Mounting Brackets Bolted In Place Once The SmartCap is Centralised On The loadbin.

INSTALLATION

ISUZU D-MAX

STEP ONE

1. REMOVE EXISTING BOLTS ON THE REAR TOP CORNERS OF THE LOAD BIN AS SHOWN AS FIGURE 2.
2. POSITION THE REAR MOUNT BRACKET RIGHT HAND IN THE REAR RIGHT HAND CORNER OF THE LOAD BIN.
3. USE TWO M6 X 25 SET SCREWS WITH TWO M6 SPRING WASHERS AND M6 FLAT WASHERS TO SCREW THE BRACKET TO THE REAR OF THE LOAD BIN.
4. REPEAT THIS PROCESS IN THE REAR MOUNT BRACKET LEFT HAND SIDE IN THE REAR LEFT HAND CORNER OF THE LOAD BIN.

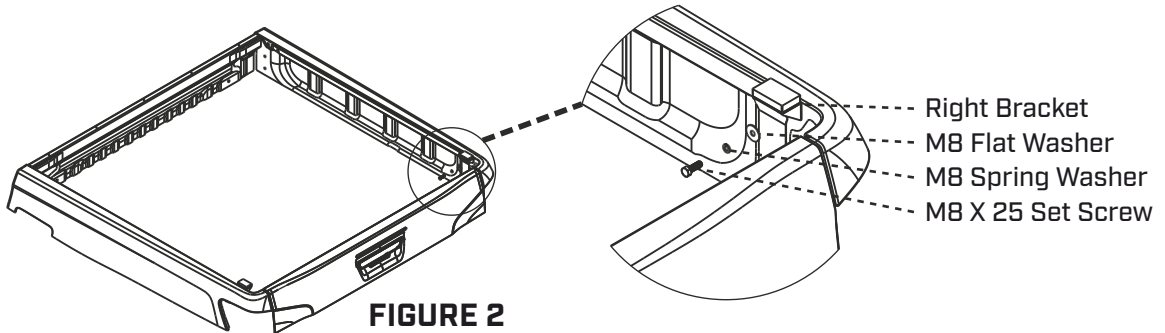

STEP TWO

1. A MINIMUM OF FOUR PEOPLE ARE RECOMMENDED TO PICK UP AND PLACE THE SMARTCAP ONTO THE TRUCK.
2. TO KEEP FROM DAMAGING YOUR D-RUBBER DURING THE INSTALLATION PROCESS, IT IS IMPORTANT YOU LIFT THE SMARTCAP IN PLACE AND DO NOT DRAG IT ACROSS THE TRUCK BED RAILS.
3. ONCE THE SMARTCAP IS CENTERED, PLACE CLAMPS IN POSITION. (SEE FIGURE 3)
4. PLACE THE SUPPLIED THIN RUBBER PAD ON THE SIDE PANEL TO PREVENT CLAMP FROM SCRATCHING THE PAINT. (SEE FIGURE 4)
5. PROCEED TO SUFFICIENTLY TORQUE THE CLAMPS TO 4.4 FT. LBS. (6 NEWTON METERS)

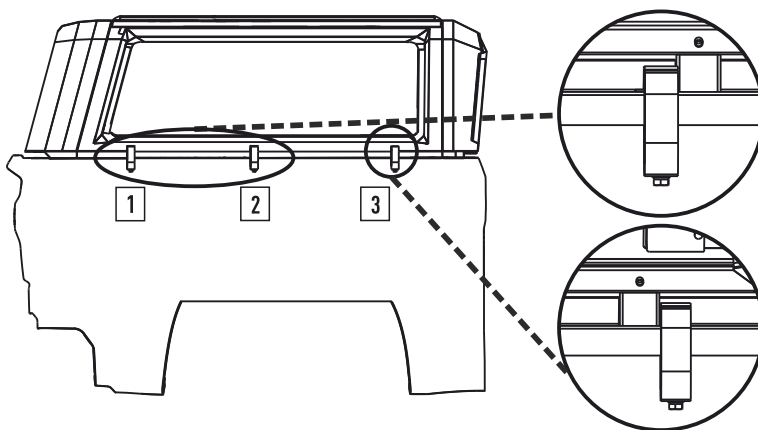

REPEAT THIS PROCEDURE ON THE OPPOSITE HAND SIDE OF THE VEHICLE.

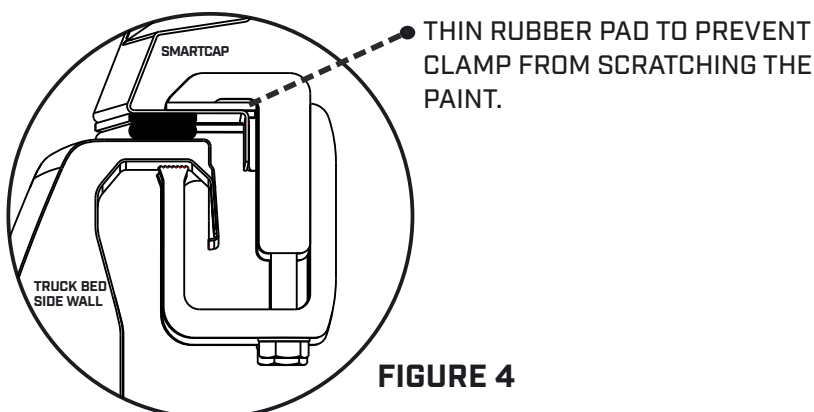

INSTALLATION

MITSUBISHI TRITON

STEP ONE

1. THE MITSUBISHI TRITON BED HAS A HEIGHT DIFFERENCE BETWEEN THE SIDES AND FRONT OF THE TRUCK BED. APPLY A FOAM STRIP TO THE LIP OF THE FRONT PANEL.
2. REMOVE THE ADHESIVE BACKING TAPE FROM THE FOAM STRIP. [SEE FIGURE 1]
3. APPLY FOAM STRIP ON THE FRONT LIP OF THE CAP FRONT FLANGE. [SEE FIGURE 2]
4. CUT TO THE CORNER. [SEE FIGURE 2]

- FIGURE 1**
- 1. FOAM STRIP
 - 2. ADHESIVE
 - 3. ADHESIVE BACKING

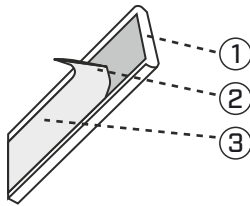

- APPLY 5X30 FOAM SEAL TAPE

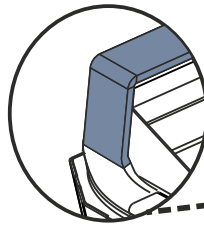

- APPLY 1 X 1700mm D-RUBBER

- APPLY 1 X 1700mm D-RUBBER

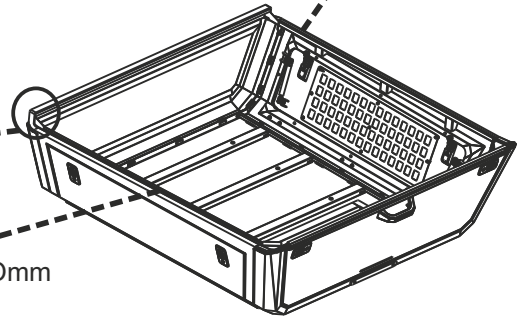

FIGURE 2

STEP TWO

1. A MINIMUM OF FOUR PEOPLE ARE RECOMMENDED TO PICK UP AND PLACE THE SMARTCAP ONTO THE TRUCK.
2. TO KEEP FROM DAMAGING YOUR D-RUBBER DURING THE INSTALLATION PROCESS, IT IS IMPORTANT YOU LIFT THE SMARTCAP IN PLACE AND DO NOT DRAG IT ACROSS THE TRUCK BED RAILS.
3. ONCE THE SMARTCAP IS CENTERED, PLACE CLAMPS IN POSITION. [SEE FIGURE 3]
4. PLACE THE SUPPLIED THIN RUBBER PAD ON THE SIDE PANEL TO PREVENT CLAMP FROM SCRATCHING THE PAINT. [SEE FIGURE 4]
5. PROCEED TO SUFFICIENTLY TORQUE THE CLAMPS TO 4.4 FT. LBS. [6 NEWTON METERS]



THIN RUBBER PAD TO PREVENT CLAMP FROM SCRATCHING THE PAINT.

13mm
[1/2 INCH]

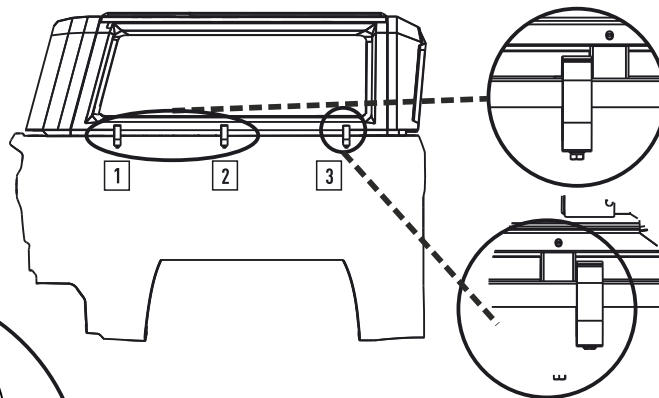
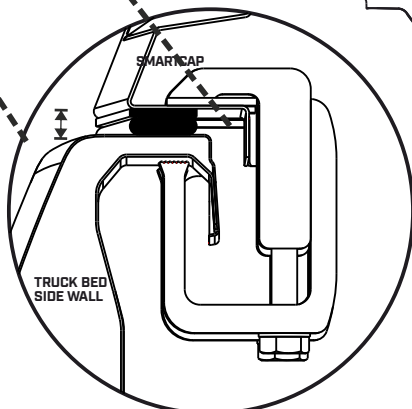

FIGURE 3

REPEAT THIS PROCEDURE ON THE OPPOSITE HAND SIDE OF THE VEHICLE.

FIGURE 4

INSTALLATION

TOYOTA LAND CRUISER

STEP ONE



1. A MINIMUM OF FOUR PEOPLE ARE RECOMMENDED TO PICK UP AND PLACE THE SMARTCAP ONTO THE TRUCK.
2. TO KEEP FROM DAMAGING YOUR D-RUBBER DURING THE INSTALLATION PROCESS, IT IS IMPORTANT YOU LIFT THE SMARTCAP IN PLACE AND DO NOT DRAG IT ACROSS THE TRUCK BED RAILS.
3. ALIGN DRILL JIG WITH VEHICLE BIN RAIL. [SEE FIGURE 3 & 4]
4. MARK HOLE POSITIONS OR DRILL HOLES WITH THE JIG IN PLACE.
5. ADD 4 OFF 30X10MM FOAM SEAL AS SHOWN IN THE BELOW IMAGE TO PREVENT DUST FROM ENTERING THE CAP FROM THE FRONT END OF THE CAB. [SEE FIGURE 4]
6. APPLY D-RUBBER AS PER BELOW IMAGE.
7. MOUNT CAP TO BIN USING 6 OFF M8X30MM S/S HEX BOLTS WITH NYLON LOCKNUTS AND 25MM S/S FENDER WASHERS. [SEE FIGURE 5]
8. INSERT 48MM PLASTIC END CAP TO THE ALLOCATED CUT OUTS.

FOAM SEAL 30X10MM AT 1595MM
FITTED TO FRONT CHANNEL

FIGURE 4

FIGURE 3

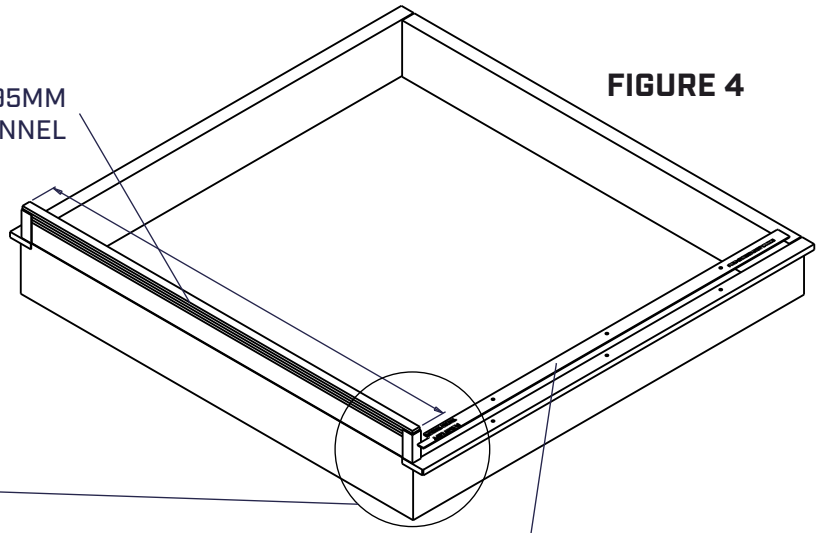
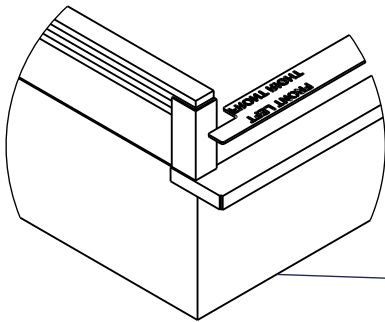

PLACE DRILL JIG FLUSH WITH
SIDE EDGE AND FRONT EDGE
FOR CORRECT DRILLING POSITION

FIGURE 5

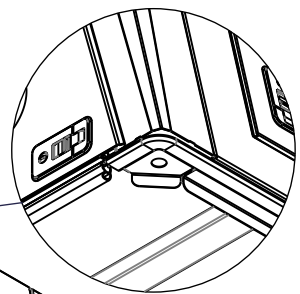

48MM PLASTIC END CAP

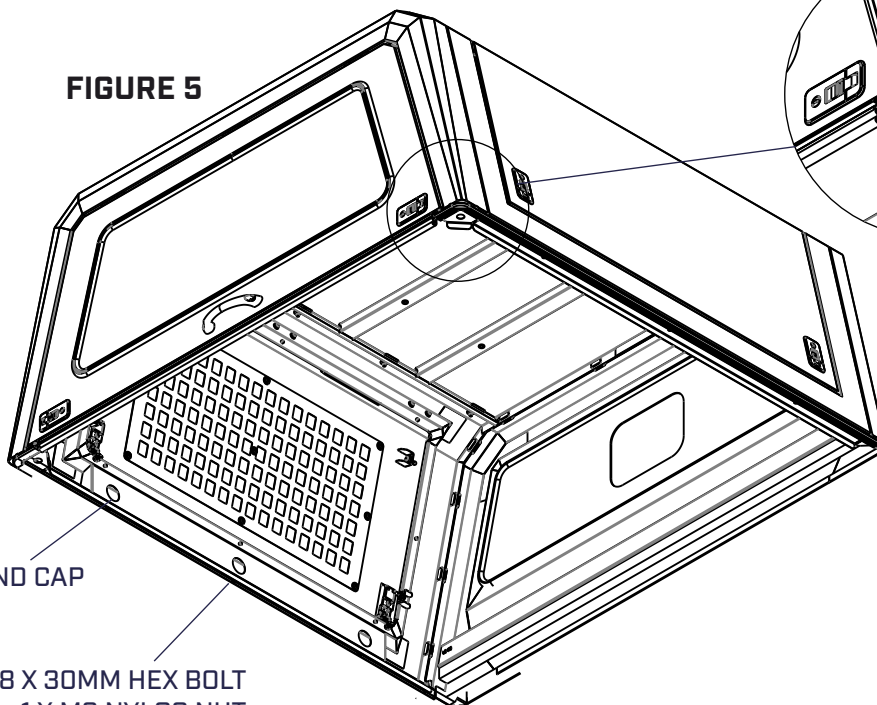

1 X M8 X 30MM HEX BOLT
1 X M8 NYLOC NUT
2 X M8 X 25MM FENDER WASHER

THIRD BRAKE LIGHT WIRING

FORD RANGER - TOYOTA HILUX - VW AMAROK - ISUZU D-MAX



WARNING

- VEHICLE SHOULD BE TURNED OFF WHEN INSTALLING THE T-HARNESS.
- ALL STEPS MUST BE FOLLOWED TO ENSURE THE CORRECT FUNCTION OF THE THIRD BRAKE LIGHT AND TRAILER PLUG.
- TO VERIFY PROPER INSTALLATION, TEST BY CONNECTING A TEST LIGHT OR PROPERLY WIRED TRAILER.



1X WIRE HARNESS
VW AMAROK



1X WIRE HARNESS
FORD RANGER DC



1X WIRE HARNESS
TOYOTA HILUX



1X WIRE HARNESS
ISUZU D-MAX

WIRING REFERENCE GUIDE

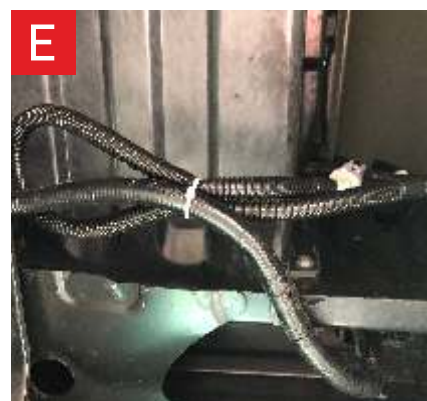

WIRING REFERENCE GUIDE

STEP ONE • REMOVE THE LEFT HAND SIDE TAILLIGHT ASSEMBLY, REVEALING THE CAVITY BEHIND THE TAILLIGHT. **REFER TO PICTURE (A)**

STEP TWO • LOCATE THIRD BRAKE LIGHT 2-PIN PLUG HANGING OFF THE SMARTCAP ON THE LEFT HAND SIDE NEAR THE TAILGATE AND CONNECT THE T-HARNESS TO IT. **REFER TO PICTURE (B)**

STEP THREE • INSERT THE SUPPLIED T-HARNESS BETWEEN THE FACTORY PLUG AND THE FACTORY 7-WAY CONNECTOR. BE SURE THAT BOTH ENDS OF THE T-HARNESS ARE FULLY INSERTED WITH THE LOCKING TABS IN PLACE. **REFER TO PICTURE (C1,2,3 & 4)**

STEP FOUR • DISCONNECT THE BRAKE LIGHT CABLE (MALE END) FROM THE TAILLIGHT ASSEMBLY AND CONNECT IT TO THE T-HARNESS (FEMALE CONNECTOR). THEN CONNECT THE T-HARNESS (MALE END) TO THE TAILLIGHT ASSEMBLY. **REFER TO PICTURE (D)**

STEP FIVE • TEST THE BRAKE LIGHTS AND TURN SIGNALS. CHECK TO MAKE SURE PROPER TURN SIGNAL FUNCTIONALITY WHEN THE BRAKE LIGHTS ARE ON.

STEP SIX • ONCE YOU ARE SURE EVERYTHING IS FUNCTIONING CORRECTLY, RE-INSTALL THE TAILLIGHT ASSEMBLY.

STEP SEVEN • THERE WILL BE EXCESS CABLE UNDER YOUR VEHICLE THAT YOU SHOULD SECURE USING A ZIP-TIE. **REFER TO PICTURE (E)**

NOTES

A series of horizontal dotted lines for writing notes.



Thank you for purchasing your SmartCap. Should you have any inquiries concerning the Assembly & Installation, please feel free to contact us.